

## Metal Körüklü Vana(Gönye Tip) / Metal Bellow Sealed Globe Valve(Angle Type)

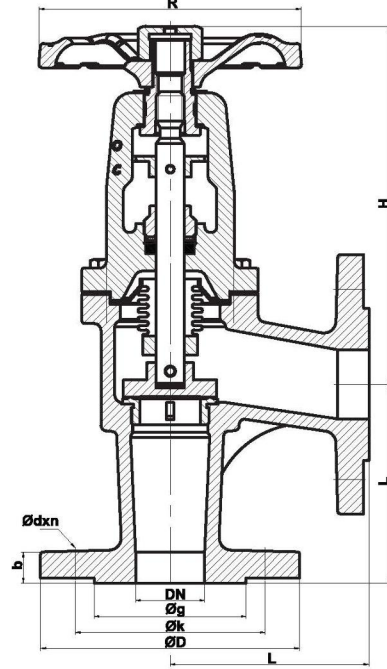

NO	PARÇA ADI	PART NAME	MALZEME / MATERIAL	
			PN16	PN25
1	GÖVDE	BODY	GG25	GGG40.3
2	SİT	SEAT	AISI 420	AISI 420
3	KAPAK	BONNET	GG25	GGG40.3
4	MİL	STEM	AISI 420	AISI 420
5	KÖRÜK	BELLOWS	AISI 316Ti	AISI 316Ti
6	CONTA	GASKET	GRAPHITE	GRAPHITE
7	SALMASTRA	PACKING	GRAPHITE	GRAPHITE
8	PUL	WASHER	ST37	ST37
9	PUL	WASHER	SPRING ST.	SPRING ST.
10	KAPAK BURCU	BONNET BUSH	STEEL	STEEL
11	SEGMAN	RETAINING RING	SPRING ST.	SPRING ST.

NO	PARÇA ADI	PART NAME	MALZEME / MATERIAL	
			PN16	PN25
12	İNDİKATÖR	INDICATOR	STEEL	STEEL
13	PİM	PIN	AISI 304	AISI 304
14	SALMASTRA BASKISI	PACKING JOINT	STEEL	STEEL
15	KLAPE	DISC	AISI 420	AISI 420
16	SARMA PİM	SPRING PIN	AISI 304	AISI 304
17	HENDİL	HANDWHEEL	GG25	GG25
18	HENDİL SOMUNU	HANDWHEEL NUT	STEEL	STEEL
19	ÇİVATA	BOLT	8.8 STEEL GALV.	8.8 STEEL GALV.
20	SETSKÜR	GRUP SCREW	8.8 STEEL	8.8 STEEL
21	GRESÖRLÜK	LUBRICATING NIPPLE	STEEL	STEEL

DN	L	ØR	H	STROK	PN16					PN25					PN40					KG			
					ØD	Øk	Øg	b	n	Ød	ØD	Øk	Øg	b	n	Ød	ØD	Øk	Øg		b	n	Ød
15	90	125	165	6	95	65	45	14	4	14	95	65	45	16	4	14	95	65	45	16	4	14	4,75
20	95	125	165	6	105	75	58	16	4	14	105	75	58	18	4	14	105	75	58	18	4	14	5,35
25	100	125	177	8	115	85	68	16	4	14	115	85	68	18	4	14	115	85	68	18	4	14	6,15
32	105	125	175	8	140	100	78	18	4	18	140	100	78	18	4	18	140	100	78	18	4	18	7
40	115	150	205	13	150	110	88	18	4	18	150	110	88	18	4	18	150	110	88	18	4	18	10,7
50	125	150	208	13	165	125	102	20	4	18	165	125	102	20	4	18	165	125	102	20	4	18	14
65	145	175	220	16	185	145	122	20	4	18	185	145	122	22	8	18	185	145	122	22	8	18	19
80	155	175	230	20	200	160	138	22	8	18	200	160	138	24	8	18	200	160	138	24	8	18	22
100	175	225	275	25	220	180	158	24	8	18	235	190	162	24	8	22	235	190	162	24	8	22	35,8
125	200	225	340	32	250	210	188	26	8	18	270	220	188	26	8	28	270	220	188	26	8	25	54
150	225	300	407	40	285	240	212	26	8	22	300	250	218	28	8	28	300	250	218	28	8	25	72
200	275	400	440	50	340	295	268	30	12	22	360	310	278	34	12	28	375	320	285	34	12	30	116

### UYGULAMA ALANLARI / APPLICATIONS

BUHAR, SICAK SU, TERMAL AKIŞKAN, KIZGIN YAĞ

STEAM, HOT WATER, THERMAL FLUIDS, HOT OIL

ÇALIŞMA ŞARTLARI / WORKING CONDITIONS : DIN 2401

BAĞLANTILAR / ENDS: DIN EN 1092-2

ÇALIŞMA BASINCI / WORKING PRESSURE : PN16, PN25, PN40

FACE TO FACE DIMENSIONS TS EN 558-1

### ÇALIŞMA SICAKLIĞI / WORKING TEMPERATURE

PN16: -10 +300°C,

PN25: -10 +350°C,

PN40: -10 +400°C

### GÖVDE SEÇENEKLERİ

GG25, GGG40.3, GSC-25