

DST-1S/1F/2F | Disc Type Steam Trap

- Insulation chamber (air warm) is adopted to lessen the affect of atmosphere and to improve the most suitable working conditions.
- The maintenance and repair of disc and seat are easy owing to its material of high-hardness-treated stainless steel and its replaceable seat.

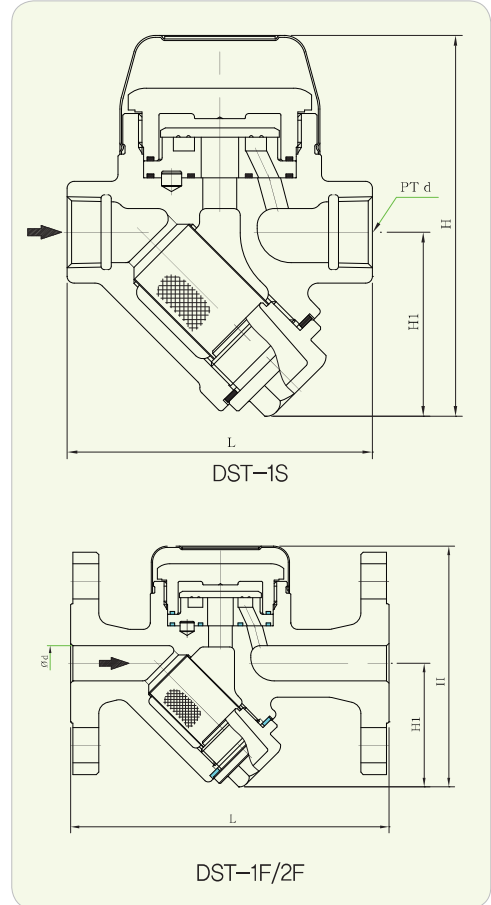

► Specifications

Working Pressure (kgf/cm ²)	Max. 16	Max. 20
	Min. 0,35	Min. 0,35
Working Temperature (°C)	220	220
Connection	DST-1S : PT Screwed	DST-2F : JIS Flanged
	DST-1F : JIS Flanged	
Materials	Body : Ductile Iron	Body : Cast Steel, Stainless Steel
	Trim : Stainless Steel	Trim : Stainless Steel

► Dimensions

Model	Size	d	L	H1	H	Connection
DST-1S	15A	PT 1/2"	90	54	104	PT Screwed
	20A	PT 3/4"	95	56	108	
	25A	PT 1"	100	58	112	
	32A	PT 1 1/4"	180	100	180	
	40A	PT 1 1/2"	180	110	205	
DST-1F DST-2F	15A	15	136	53	103	JIS 5K Flanged JIS 16K Flanged (DST-1F) JIS 20K Flanged (DST-2F)
	20A	20	140	55	108	
	25A	25	150	58	113	
	32A	32	190	103	185	
	40A	40	260	112	206	
	50A	50	260	112	206	

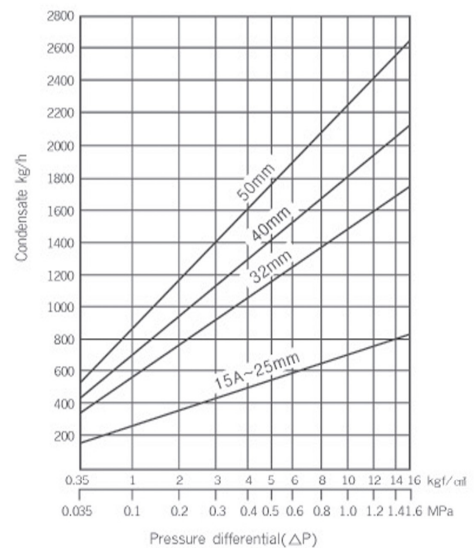

※ DST-2F – ANSI and DIN Flange are available upon request