

PRE-1F/2F | Pressure Reducing Valve—Piston Type

► Specifications

| Model | PRE-1F | PRE-2F |
|--|--|--|
| Inlet Pressure (kgf/cm ²) | 10~16 | 10~20 |
| Outlet Pressure (kgf/cm ²) | 0,5~12 | 0,5~15 |
| Type | Piston Type | Piston Type |
| Max Reducing Ratio | 10 : 1 | 10 : 1 |
| Working Temperature (°C) | 150 | 150 |
| Working Fluid | Air(Gas), Water(Liquid) | Air(Gas), Water(Liquid) |
| Connection | JIS 10K, 16K Flanged | JIS 16K, 20K Flanged |
| Materials | Body : Ductile Iron | Body : Cast Steel, Stainless Steel |
| | Trim : Stainless Steel, Synthetic Rubber | Trim : Stainless Steel, Synthetic Rubber |

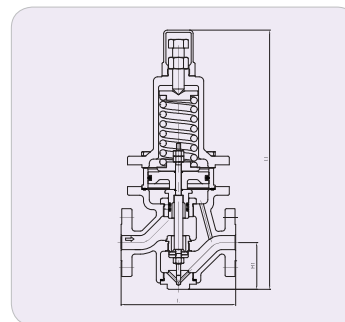

► Dimensions

| Part Size | 15A | 20A | 25A | 32A | 40A | 50A | 65A | 80A | 100A | 125A | 150A | 200A |
|-----------|-----|-----|-----|-----|-----|-----|-----|-----|------|------|------|------|
| L | 160 | 160 | 160 | 180 | 180 | 190 | 251 | 270 | 300 | 370 | 400 | 484 |
| H1 | 65 | 65 | 65 | 65 | 76 | 78 | 95 | 107 | 127 | 148 | 163 | 163 |
| H | 361 | 361 | 361 | 361 | 436 | 445 | 554 | 574 | 656 | 796 | 832 | 832 |

※ PRE-2F – ANSI and DIN Flange are available upon request

PRE-3F | Pressure Reducing Valve—Piston Type

► Specifications

| | |
|--|--|
| Inlet Pressure (kgf/cm ²) | 30~40 |
| Outlet Pressure (kgf/cm ²) | 0,5~24 |
| Max Reducing Ratio | 10 : 1 |
| Working Temperature (°C) | 150 |
| Working Fluid | Air(Gas), Water(Liquid) |
| Connection | JIS 30K, 40K Flanged |
| Materials | Body : Cast Steel, Stainless Steel |
| | Trim : Stainless Steel, Synthetic Rubber |

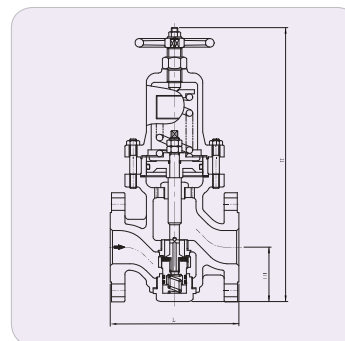

► Dimensions

| Size | Part | Connection | L | H1 | H |
|------|----------------------------|------------|-----|----|-----|
| 15A | JIS 30K, 40K RF Flanges | | 145 | 76 | 316 |
| 20A | | | 145 | 76 | 316 |
| 25A | | | 150 | 76 | 316 |
| 32A | | | 180 | 87 | 346 |
| 40A | | | 180 | 82 | 351 |
| 50A | | | 280 | 82 | 351 |

※ PRE-3F – ANSI and DIN Flange are available upon request