

# Primary Regulating Valve

## DRG-1F/2F | Primary Regulating Valve—Direct Acting Type

- Self operated pressure regulating valve for discharging the over pressure to maintain a regular pressure at the pipe arrangement so it is a kind of relief valve.
- It is used for air regulating equipment.

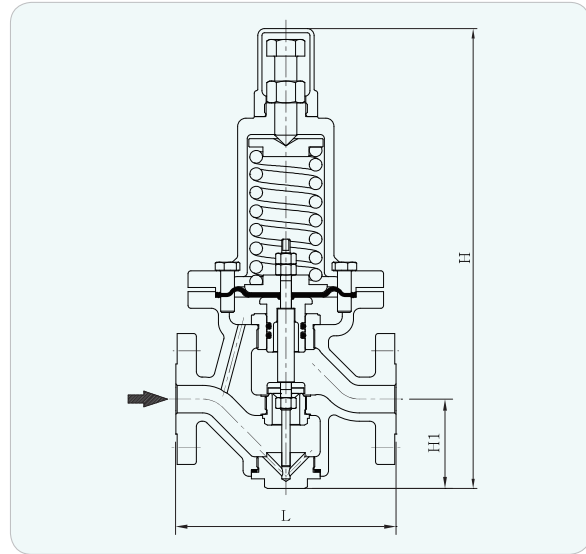

### ► Specifications

Model	DRG-1F	DRG-2F
Inlet Pressure (kgf/cm <sup>2</sup> g)	10	20
Outlet Pressure (kgf/cm <sup>2</sup> g)	0,5~7	0,5~7
Type	Diaphragm Type	Diaphragm Type
Working Temperature (°C)	80	80
Working Fluid	Air(Gas), Water(Liquid)	Air(Gas), Water(Liquid)
Connection	JIS 10K Flanged	JIS 20K Flanged
Materials	Body : Ductile Iron	Body : Cast Steel, Stainless Steel
	Trim : Stainless Steel, Synthetic Rubber	Trim : Stainless Steel, Synthetic Rubber

### ► Dimensions

Size	Part	15A	20A	25A	32A	40A	50A	65A	80A	100A	125A	150A	200A
L		160	160	160	180	180	190	251	270	300	370	400	484
H1		65	65	65	76	76	78	95	107	127	148	163	163
H		335	335	335	400	400	407	505	525	598	728	764	764

※ DRG-2F – ANSI and DIN Flange are available upon request