



## Servo-assisted 2/2-way piston valve up to 450 bar

- Hydrogen-resistant screwed valve body
- Function test with forming gas at nominal pressure
- Piston system with mechanical seal bearings
- Explosion-proof variant ATEX and IECEx
- Inspection holes for monitoring the process seal

Product variants described in the data sheet may differ from the product presentation and description.

### Type description

The valve Type 6481 is a servo-controlled piston valve for hydrogen applications up to a nominal diameter of 50 mm. A minimum differential pressure of 1 bar is required to support the opening and closing process. To increase the pressure resistance in contact with hydrogen, the plunger guiding tube and stopper are screwed together. Certified 3.1 materials suitable for hydrogen and carbon-coated magnetic steels are used. Each valve is subject to a functional test at maximum nominal pressure. The external leakage is  $5 \times 10^{-5}$  mbar l/s. On request, the push-over coil can be provided as a Zone 1 or Category 2 explosion-proof variant.

## Table of contents

<b>1. General technical data</b>	<b>3</b>
<b>2. Circuit functions</b>	<b>3</b>
<b>3. Approvals and conformities</b>	<b>4</b>
3.1. General notes .....	4
3.2. Conformity .....	4
3.3. Standards .....	4
3.4. Explosion protection .....	4
<b>4. Materials</b>	<b>4</b>
4.1. Bürkert resistApp .....	4
<b>5. Dimensions</b>	<b>5</b>
5.1. Threaded variant .....	5
Standard variant .....	5
<b>6. Performance specifications</b>	<b>6</b>
6.1. Power consumption .....	6
<b>7. Ordering information</b>	<b>6</b>
7.1. Bürkert eShop .....	6
7.2. Bürkert product filter .....	6
7.3. Bürkert Product Enquiry Form .....	6
7.4. Ordering chart .....	7
Standard variant .....	7
ATEX/IECEx terminal box variant .....	7

DTS 1000636672 EN Version: A Status: RL (released | freigegeben | valide) printed: 23.10.2025

## 1. General technical data

Product properties	
Dimensions	Further information can be found in chapter "5. Dimensions" on page 5.
<b>Material</b>	
Seal	PCTFE/PTFE/FKM, PCTFE/PTFE/EPDM and PEEK/PTFE
Body	Stainless steel 1.4404/316L
Coil	Powder-coated steel
<b>Tightness</b>	
Permissible internal leakage rate	$2 \times 10^{-3}$ mbar l/s at 20 bar, $5 \times 10^{-5}$ mbar l/s at nominal pressure
Permissible external leakage rate	$5 \times 10^{-5}$ mbar l/s
Max. switching cycles regarding leakage rates	Approx. 100,000 at $\Delta p = 100 \dots 200$ bar
Max. absolute switching cycles (service)	Approx. 250,000 (1 year) at $\Delta p = 100 \dots 200$ bar
<b>Pressure</b>	
Pressure level	DN 12 and DN 25: PN 450 bar DN 40 and DN 50: PN 330 bar
Differential pressure <sup>1)</sup>	1...450 bar Further information can be found in chapter "7.4. Ordering chart" on page 7.
Orifice	DN 12, DN 25, DN 40 and DN 50
Circuit function	A Further information can be found in chapter "2. Circuit functions" on page 3.
Thermal insulation class of solenoid coil	Class H
<b>Performance data</b>	
Duty cycle	100 % continuous operation
<b>Electrical data</b>	
Operating voltage	24 V DC, 24 V 50 Hz, 24 V 60 Hz, 120 V 60 Hz, 230 V 50 Hz (other voltages on request)
Voltage tolerance	$\pm 10$ %
<b>Medium data</b>	
Operating medium <sup>2)</sup>	Hydrogen
Medium temperature	- 27 °C...+ 80 °C
Viscosity	Max. 22 mm <sup>2</sup> /s (22 cSt)
<b>Product connections</b>	
Electrical connection	Terminal box M16×1.5 (ATEX)
Port connection	G 3/8, G 1, G 1 1/2, G 2
<b>Approvals and conformities</b>	
Degree of protection	IP65 according to DIN 60529
Explosion protection	Further information can be found in chapter "3.4. Explosion protection" on page 4.
<b>Environment and installation</b>	
Installation position	As required, preferably with actuator upright
Ambient temperature	- 27 °C...+ 50 °C

1.) Pressure data: overpressure to atmospheric pressure, depending on orifice, tightness seal or nominal pressure

2.) Medium resistance according to material combination

## 2. Circuit functions

Symbol	Description
	<b>Circuit function A (CF A)</b> 2/2-way solenoid valve Direct-acting Normally closed

### 3. Approvals and conformities

#### 3.1. General notes

- The approvals and conformities listed below must be stated when making enquiries. This is the only way to ensure that the product complies with all required specifications.
- Not all available variants can be supplied with the below mentioned approvals or conformities.

#### 3.2. Conformity



In accordance with the Declaration of Conformity, the product is compliant with the EU Directives. This includes the following directives:

- Pressure equipment directive 2014/68/EU category IV
- Machinery directive 2006/42/EC

#### 3.3. Standards

The applied standards which are used to demonstrate compliance with the EU Directives are listed in the EU-Type Examination Certificate and/or the EU Declaration of Conformity.

#### 3.4. Explosion protection

Approval	Description	
 	<b>Optional: Explosion protection (valid for coils with terminal box)</b>	
	<b>As a category 3 device suitable for zone 2/22.</b>  <b>ATEX:</b> II 3G Ex ec IIC T3 Gc III 3D Ex mb tb IIIB T155 °C Db  <b>IECEX:</b> Ex ec IIC T3 Gc Ex mb tb IIIB T155 °C Db	<b>As a category 2 device suitable for zone 1/21 (expected to be available from Q2 2026).</b>  <b>ATEX:</b> II 2G Ex e mb IIC T4 Gb II 2D Ex tb mb IIIC T130 °C Db  <b>IECEX:</b> Ex e mb IIC T4 Gb Ex tb mb IIIC T130 °C Db

### 4. Materials

#### 4.1. Bürkert resistApp

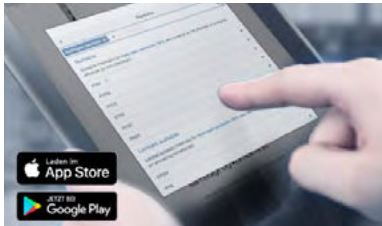

**Bürkert resistApp – Chemical resistance chart**

You want to ensure the reliability and durability of the materials in your individual application case? Verify your combination of media and materials on our website or in our resistApp.

[Start chemical resistance check](#)

DTS 1000636672 EN Version: A Status: RL (released | freigegeben | valide) printed: 23.10.2025

## 5. Dimensions

### 5.1. Threaded variant

#### Standard variant

**Note:**

Dimensions in mm

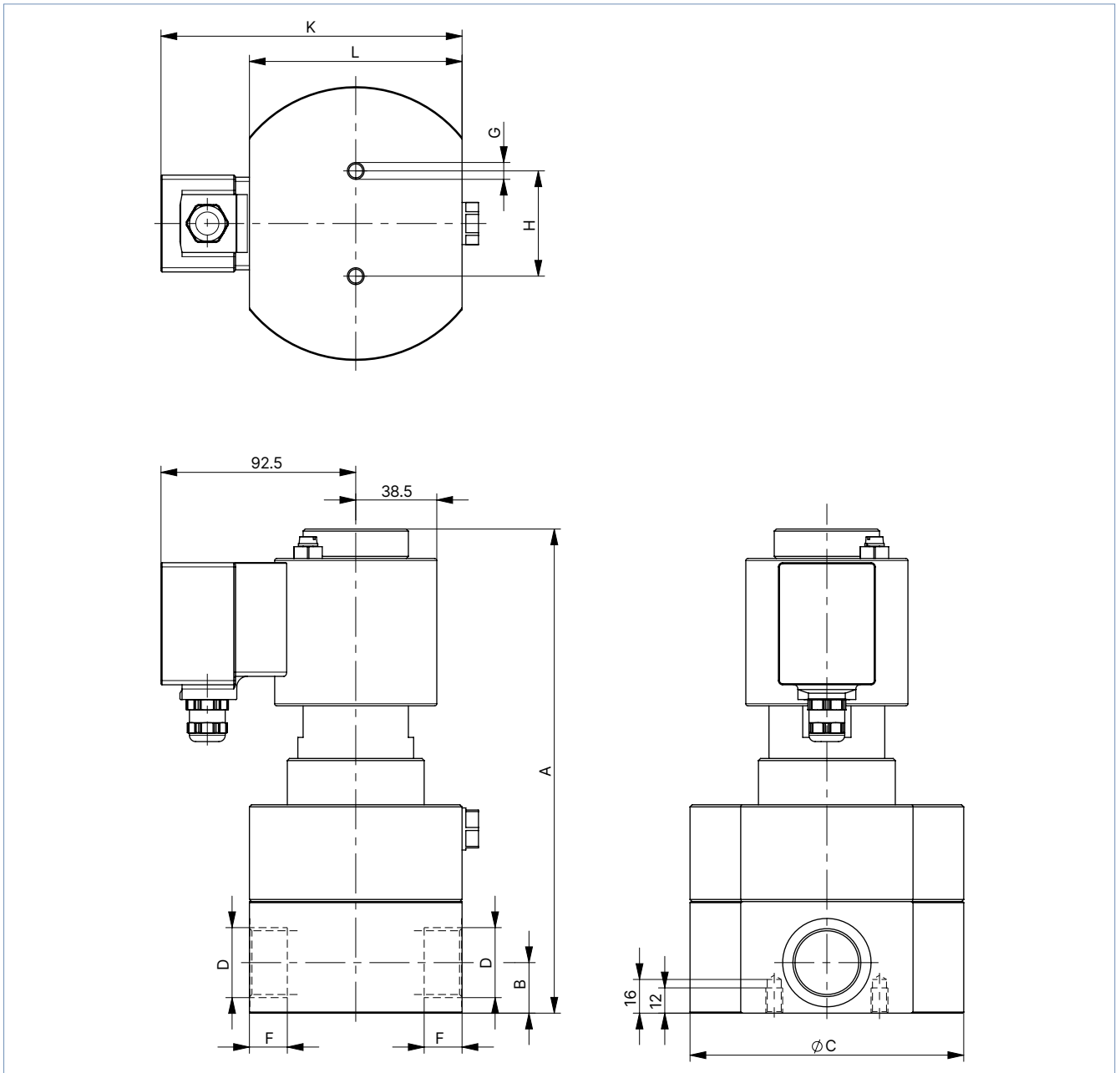

DN	A	B	ØC	D	F	G	H	K	L
12	204.5	20.5	84	G 3/8	12.5	M8	30	141	78
25	230	24	130	G 1	18	M8	50	150	101
40	271	40	159	G 1 1/2	22	M8	100	162.5	140
50	287	42	170	G 2	27	M12	120	170	155

## 6. Performance specifications

### 6.1. Power consumption

**Note:**

The cable plug for AC valves contains an integrated rectifier.

Coil size [mm]	Cold performance [W]
77 (M)	46
77 (M) ATEX	30

## 7. Ordering information

### 7.1. Bürkert eShop



#### Bürkert eShop – Easy ordering and quick delivery

You want to find your desired Bürkert product or spare part quickly and order directly? Our online shop is available for you 24/7. Sign up and enjoy all the benefits.

[Order online now](#)

### 7.2. Bürkert product filter

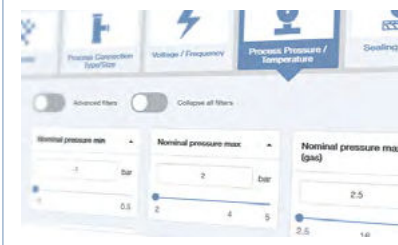

#### Bürkert product filter – Get quickly to the right product

You want to select products comfortably based on your technical requirements? Use the Bürkert product filter and find suitable articles for your application quickly and easily.

[Try out our product filter](#)

### 7.3. Bürkert Product Enquiry Form

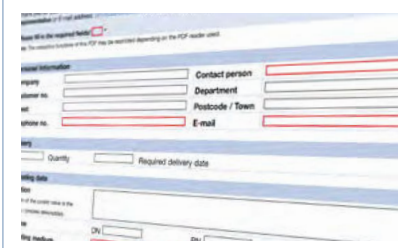

#### Bürkert Product Enquiry Form – Your enquiry quickly and compactly

Would you like to make a specific product enquiry based on your technical requirements? Use our Product Enquiry Form for this purpose. There you will find all the relevant information for your Bürkert contact. This will enable us to provide you with the best possible advice.

[Fill out the form now](#)

DTS 1000636672 EN Version: A Status: RL (released | freigegeben | valide) printed: 23.10.2025

### 7.4. Ordering chart

#### Standard variant

**Note:**

Other variants are available on request.

Circuit function	Port connection	Orifice [mm]	K <sub>v</sub> value water [m <sup>3</sup> /h]	Pressure range (MAWP <sup>1.)</sup> [bar]	Article no.		
					024/DC [V/Hz]	024/AC [V/Hz]	230/AC [V/Hz]
<b>Stainless steel body with threaded connection, electrical connection via terminal box</b>							
<b>CF A</b> 2/2-way solenoid valve Direct-acting Normally closed 	<b>Seal material PCTFE/PTFE/FKM</b>						
	G 3/8	12.0	3.3	1...450	20093215	20093217	20093218
	G 1	25.0	13.0	1...450	20093219	20093220	20093221
	<b>Seal material PEEK/PTFE</b>						
	G 1 1/2	40.0	24.0	1...330	20093222	20093223	20093224
	G 2	50.0	32.0	1...330	20093225	20093226	20093227

1.) Maximum allowable working pressure

#### ATEX/IECEX terminal box variant

**Note:**

As a category 3 device suitable for zone 2/22.

Circuit function	Port connection	Orifice [mm]	K <sub>v</sub> value water [m <sup>3</sup> /h]	Pressure range (MAWP <sup>1.)</sup> [bar]	Article no.		
					024/DC [V/Hz]	024/AC [V/Hz]	230/AC [V/Hz]
<b>Stainless steel body with threaded connection, electrical connection via terminal box</b>							
<b>CF A</b> 2/2-way solenoid valve Direct-acting Normally closed 	<b>Seal material PCTFE/PTFE/FKM</b>						
	G 3/8	12.0	3.3	1...450	20122058	o. r.	20127882
	<b>Seal material PCTFE/PTFE/EPDM</b>						
	G 1	25.0	13.0	1...350	o. r.	o. r.	o. r.
	<b>Seal material PEEK/PTFE</b>						
	G 1 1/2	40.0	24.0	1...250	o. r.	o. r.	o. r.
G 2	50.0	32.0	1...250	o. r.	o. r.	o. r.	

o. r. = on request

1.) Maximum allowable working pressure

DTS 1000636672 EN Version: A Status: RL (released | freigegeben | valide) printed: 23.10.2025