







Electronic pressure controller (EPC)

- Precise flow pressure control
- Upstream pressure controller
- Suitable for pressure control up to 4 bar abs
- Integrated PI-control algorithm
- Simpler device exchange due to configuration memory

Product variants described in the data sheet may differ from the product presentation and description.

Can be combined with

	Type 8741 ▶ Mass flow controller (MFC)/ mass flow meter (MFM) for gases
	Type 8742 ▶ Mass flow controller (MFC)/ mass flow meter (MFM) for gases
	Type 8743 ▶ Mass flow controller (MFC)/ mass flow meter (MFM) for gases
	Type 8744 ▶ Mass flow controller (MFC)/ mass flow meter (MFM) for gases

Type description

Type 8761 is a device for precise pressure control of gas flows. The device regulates the flow pressure which is present at the inlet of the device (upstream). The actual value supplied by the pressure sensor is compared in the digital control electronics with the set-point value specified via Industrial Ethernet or analogue. If there is a control difference, the actuating variable output to the proportional valve is modified using a PI-control algorithm. This means that the pressure can be kept at a fixed value or followed a predetermined profile, regardless of flow fluctuations or other changes in the system. A low-friction proportional valve as an actuator ensures high response sensitivity and good control characteristics of the device.

Table of contents

1. General technical data	3
<hr/>	
2. Approvals and conformities	4
2.1. General notes	4
2.2. Conformity	4
2.3. Standards	4
2.4. North America (USA/Canada)	4
<hr/>	
3. Materials	4
3.1. Bürkert resistApp	4
<hr/>	
4. Dimensions	5
4.1. Threaded variant connections	5
Small nominal flow rates, with internal thread.....	5
Small nominal flow rates, compatible with VCR®	5
Small nominal flow rates, with clamp connection DN 15...1/2"	5
4.2. Threaded variant.....	6
4.3. Sub-base variant	7
<hr/>	
5. Product connections	8
5.1. Communication	8
Industrial Ethernet	8
Analogue	8
<hr/>	
6. Product operation	9
6.1. Measurement principle	9
<hr/>	
7. Product accessories	10
7.1. Bürkert Communicator software	10
7.2. Connecting Type 8761 with the Bürkert Communicator software	11
7.3. Configuration management for easy device replacement.....	11
7.4. Web server for Industrial Ethernet variant	11
<hr/>	
8. Ordering information	11
8.1. Bürkert eShop	11
8.2. Bürkert product filter	11
8.3. Ordering chart accessories.....	12

1. General technical data

Product properties	
Dimensions	Further information can be found in chapter "4. Dimensions" on page 5.
Material	
Seal	FKM or EPDM (depending on gas)
Housing	PC (polycarbonate)
Base block	Aluminium or stainless steel 1.4401/316L
Wetted parts	Stainless steel 1.4310/302, 1.4113/434, 1.4305/303, 1.4404/316L
Total weight	Approx. 500 g (aluminium base block)
Configuration management	Further information can be found in chapter "7.3. Configuration management for easy device replacement" on page 11.
LED display ^{1.)}	RGB-LED according to NAMUR NE107
Performance data	
Pressure range	0...4 bar abs
Nominal flow range (Q_N) ^{2.)}	< 200 l_N/min ^{2.)}
Measuring accuracy	± 0.25 % FS (under calibration conditions and after 1 min warm-up time to achieve the best measuring conditions)
Repeatability	± 0.1 % FS
Turndown ratio	1:50
Actuator (proportional valve)	Normally closed
Electrical data	
Operating voltage	24 V DC
Power consumption ^{3.)}	Max. 3...6.5 W
Residual ripple	± 2 %
Voltage tolerance	± 10 %
Electrical connection	
Analogue variant	D-Sub plug, 9-pin, terminal strip, 6-pin
Industrial Ethernet variant	2 x RJ45 socket (switch)
Medium data	
Operating medium	Neutral, pure gases (others on request)
Calibration medium	Air
Medium temperature	-10 °C...+70 °C (-10 °C...+60 °C with oxygen)
Product connections	
Analogue interface	4...20 mA, 0...20 mA, 0...10 V or 0...5 V Input impedance: > 20 kΩ (voltage) resp. < 300 Ω (current) Maximum current: 10 mA (voltage output) Maximum load: 400 Ω (current output)
Digital communication interface	Industrial Ethernet: EtherCAT®, EtherNet/IP, Modbus TCP, PROFINET
Port connection	G ¼, NPT ¼, sub-base or vacuum fitting ¼, clamp connection
Approvals and conformities	
Certificate	Material certificate 3.1 (optionally)
North America (USA/Canada)	Further information can be found in chapter "2.4. North America (USA/Canada)" on page 4.
Environment and installation	
Installation position	Horizontal or vertical
Storage temperature	-10 °C...+70 °C
Relative air humidity	Max. 95 % at +55 °C, non-condensing
Degree of protection	IP20
Ambient temperature	-10 °C...+50 °C
Accessories	
Software	Bürkert Communicator Further information can be found in chapter "7.1. Bürkert Communicator software" on page 10.

1.) For a detailed description of LED colours see **operating instructions Type 8761** ▶

2.) Index N: flow rates with respect to 1.013 bar abs and 0 °C

3.) Information based on the typical power consumption (at +23 °C ambient temperature, nominal flow rate and 30 min closed-loop control mode). The specifications according to UL 61010-1 may deviate (see **operating instructions Type 8761** ▶).

2. Approvals and conformities

2.1. General notes

Note:

- The approvals and conformities listed below must be stated when making enquiries. This is the only way to ensure that the product complies with all required specifications.
- Not all available variants can be supplied with the below mentioned approvals or conformities.

2.2. Conformity

In accordance with the Declaration of Conformity, the product is compliant with the EU Directives.

2.3. Standards

The applied standards which are used to demonstrate compliance with the EU Directives are listed in the EU-Type Examination Certificate and/or the EU Declaration of Conformity.

2.4. North America (USA/Canada)

Approval	Description
	<p>Optional: UL Listed for the USA and Canada The products are UL Listed for the USA and Canada according to:</p> <ul style="list-style-type: none"> • UL 61010-1 (ELECTRICAL EQUIPMENT FOR MEASUREMENT, CONTROL, AND LABORATORY USE – Part 1: General Requirements) • CAN/CSA-C22.2 No. 61010-1

3. Materials

3.1. Bürkert resistApp

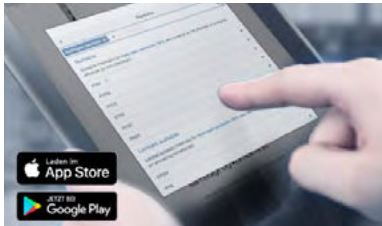

Bürkert resistApp – Chemical resistance chart

You want to ensure the reliability and durability of the materials in your individual application case? Verify your combination of media and materials on our website or in our resistApp.

[Start chemical resistance check](#)

DTS 1000613078 EN Version: J Status: RL (released | freigegeben | valide) printed: 16.12.2025

4. Dimensions

4.1. Threaded variant connections

Small nominal flow rates, with internal thread

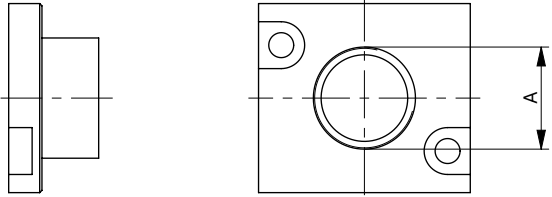
Dimensions	Thread (A)	Thread depth [mm]
		G 1/4
	NPT 1/4	12

Small nominal flow rates, compatible with VCR®

Note:

Dimensions in mm

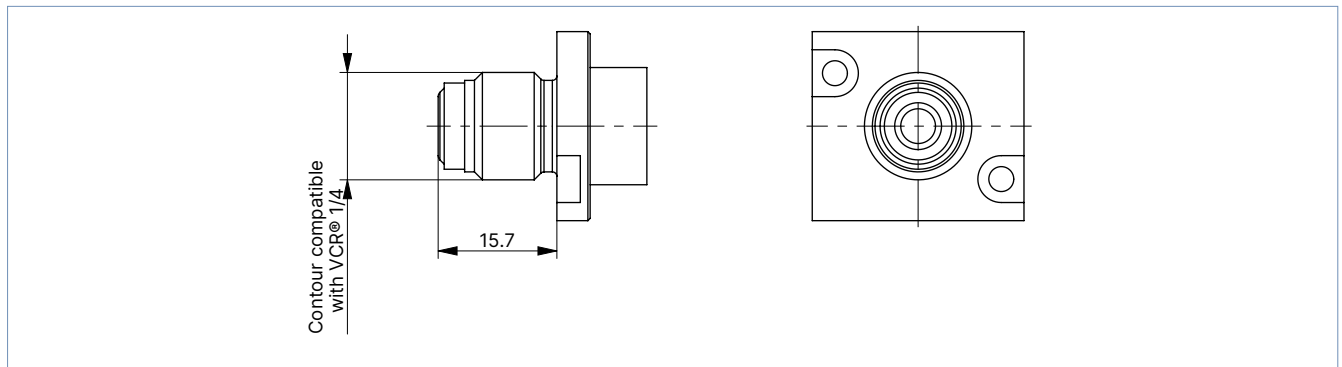

Small nominal flow rates, with clamp connection DN 15...1/2"

Note:

Dimensions in mm

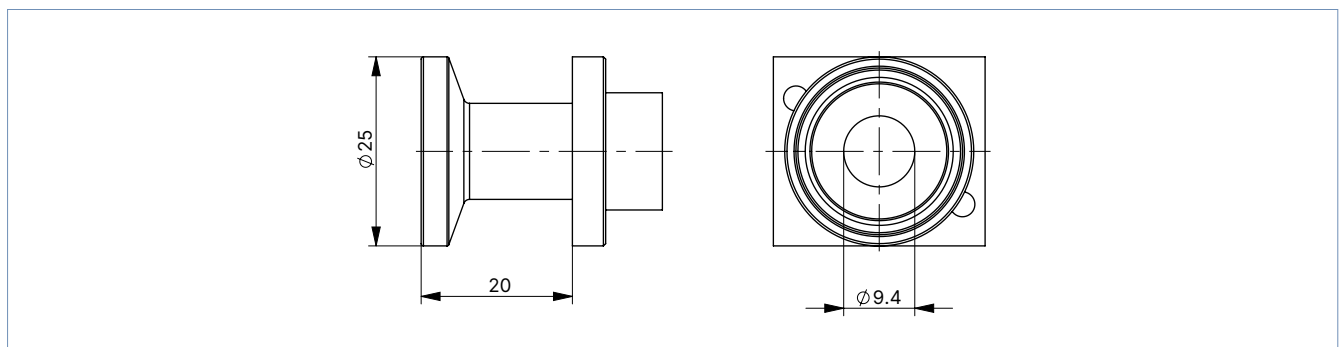

4.2. Threaded variant

Note:

Dimensions in mm

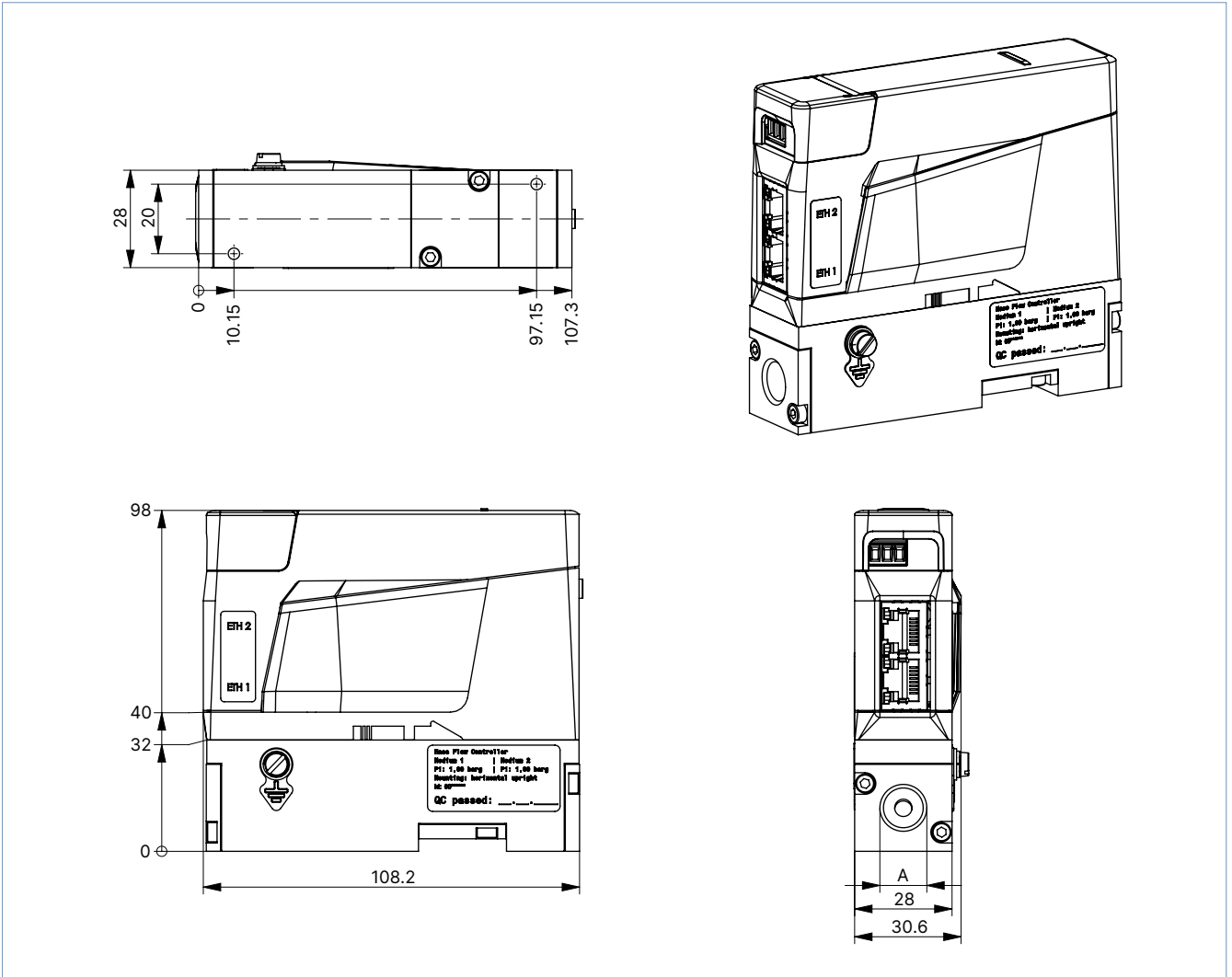

4.3. Sub-base variant

Note:

Dimensions in mm

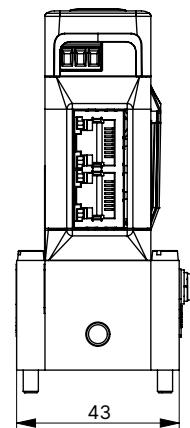
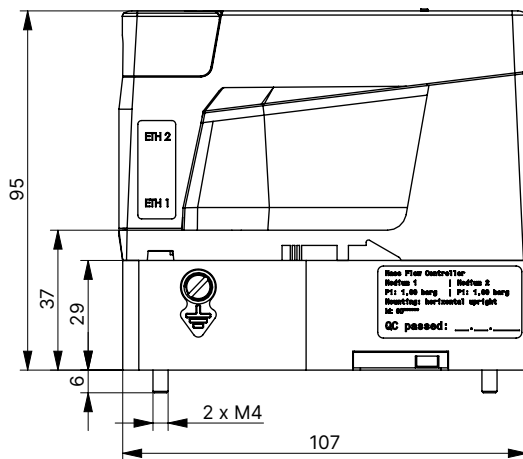
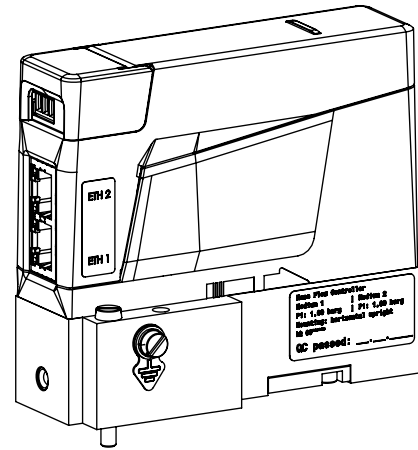
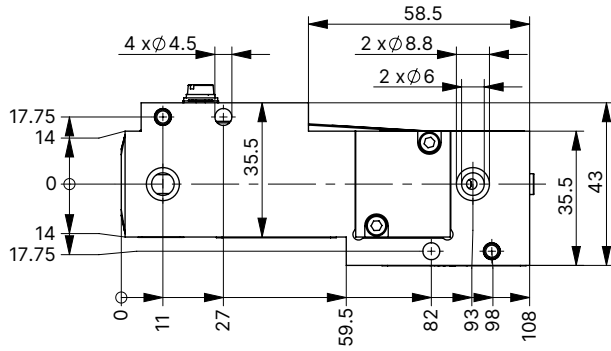

DTS 1000613078 EN Version: J Status: RL (released | freigegeben | valide) printed: 16.12.2025

5. Product connections

5.1. Communication

Industrial Ethernet

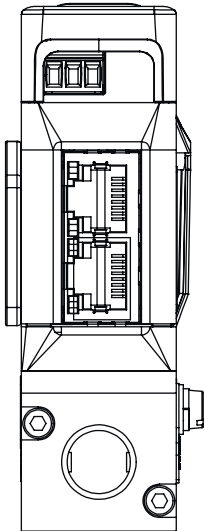

Terminal strip, 3-pin	Pin	Assignment
	1	FE (functional earth)
	2	DGND
	3	24 V

RJ45 socket	Pin	Assignment
	1	TX +
	2	TX -
	3	RX +
	4	Not connected
	5	Not connected
	6	RX -
	7	Not connected
	8	Not connected
Housing		Shielding

Analogue

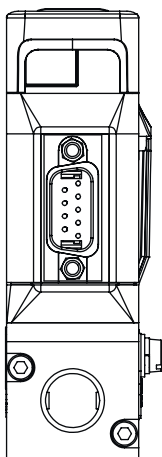

D-Sub plug, 9-pin	Pin	Assignment
	1	Digital input
	2	GND (for supply voltage and digital input)
	3	24 V
	4	Relay, normally closed contact
	5	Relay, reference contact
	6	Set-point value input +
	7	Set-point value input GND
	8	Actual value output +
	9	Actual value output GND
Housing		Shielding

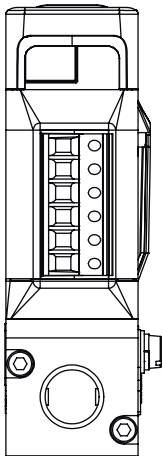

Terminal strip, 6-pin	Pin	Assignment
	1	24 V
	2	GND
	3	Set-point value input +
	4	Set-point value input GND
	5	Actual value output +
	6	Actual value output GND

6. Product operation

6.1. Measurement principle

A pressure measuring cell is used as sensor in the flow channel. The key part of the pressure measuring cell is the pressure diaphragm (highlighted in purple) with its piezoresistors which are located on the surface as strain gauges. For the measurement, four piezoresistors are connected to form a Wheatstone measuring bridge. The position of the resistances is selected so that a deflection of the diaphragm at two opposite resistances leads to a resistance change in the same direction (positive or negative).

If this measuring bridge is fed with a constant current, the measured bridge voltage is proportional to the measured pressure (absolute pressure). The pressure sensor provides a precise and temperature-compensated pressure value.

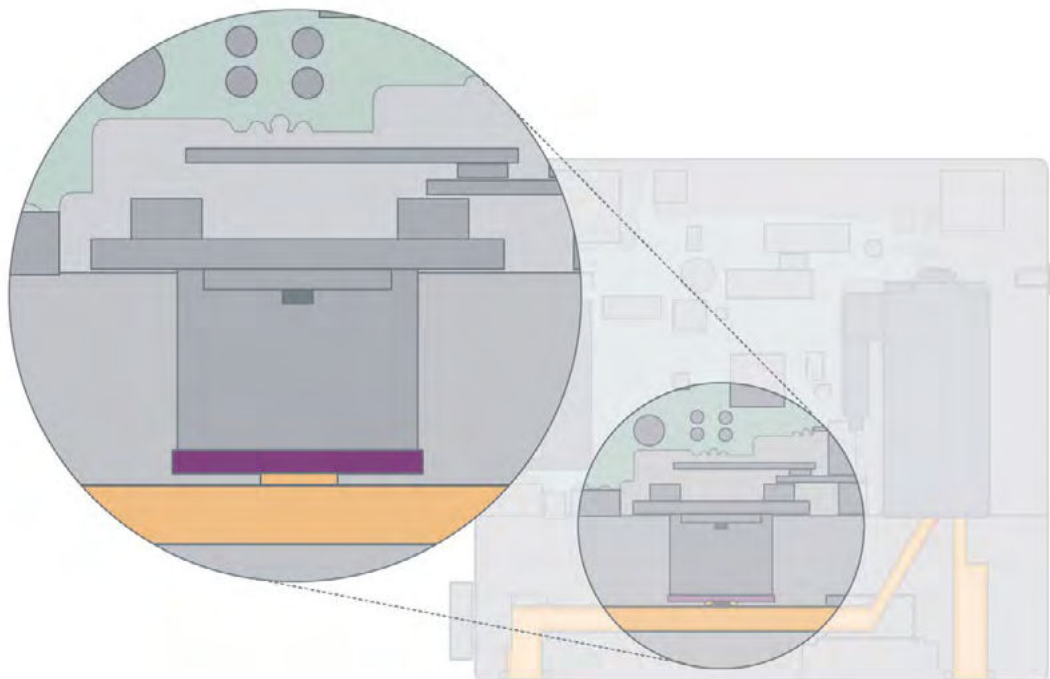

The illustration shows the sub-base variant of the EPC Type 8761.

7. Product accessories

7.1. Bürkert Communicator software

Note:

The corresponding communication software can be downloaded from the website [Type 8920](#) ▶.

The Bürkert Communicator is the most important software component of the EDIP (Efficient Device Integration Platform). Various features of this universal tool simplify the configuration and parametrisation of devices equipped with a digital CANopen-based interface. With this tool, the user has a complete overview of cyclic process values as well as acyclic diagnostic data. The integrated graphical programming environment enables the creation of decentralised sub-system control functions. The connection to the PC is established with a USB-büS interface set. The adapter is available as an accessory (see [“8.3. Ordering chart accessories” on page 12](#)).

The Bürkert Communicator enables:

- Configuration, parametrisation and diagnosis of EDIP devices / networks
- Switching between defined gases
- Easy and comfortable mapping of cyclic values
- Graphic display, monitoring and storage of process values
- Firmware update of the connected EDIP devices
- Saving and restoring device configurations
- Zero-point adjustment in case of changed ambient conditions
- Guided re-calibration routine

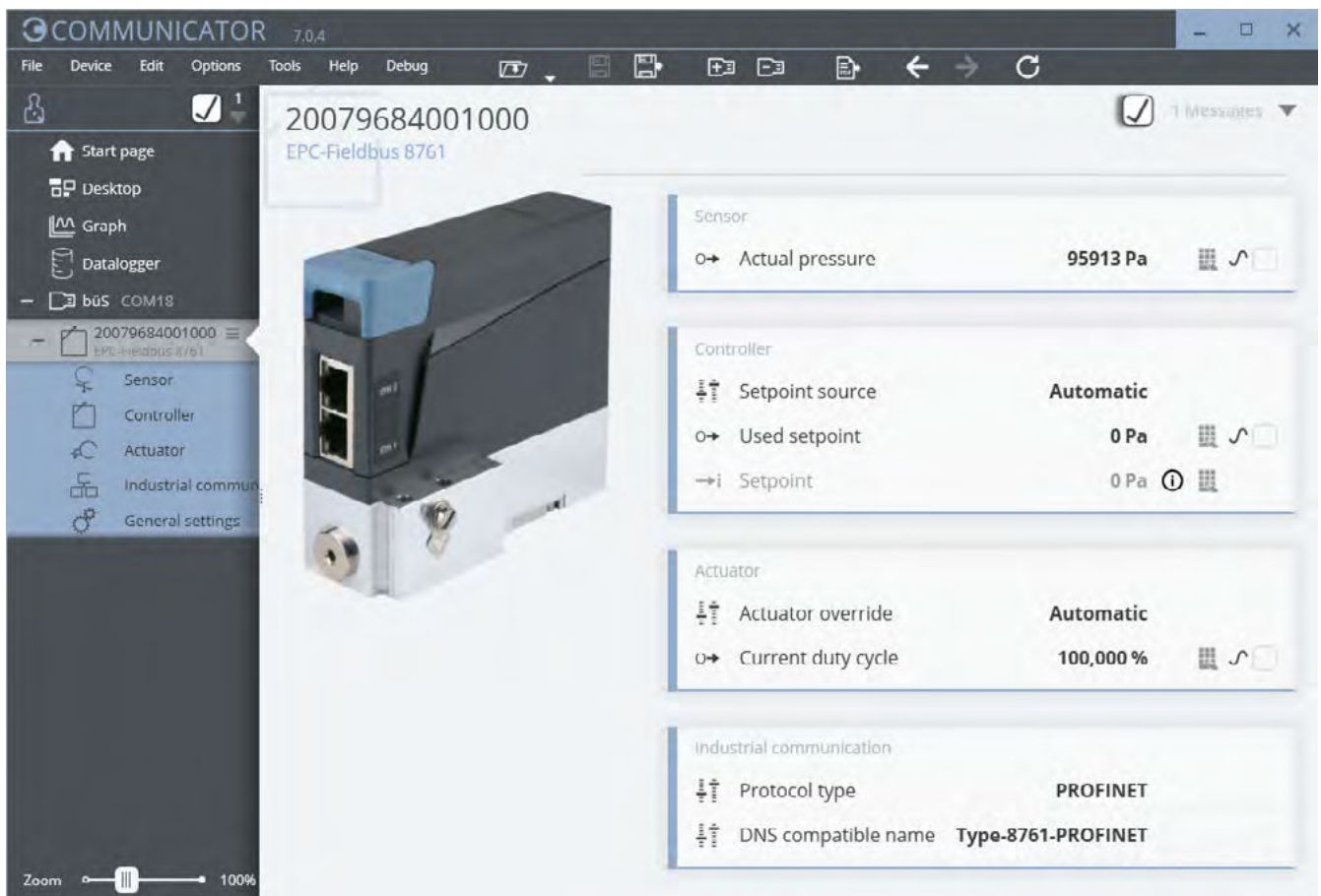

7.2. Connecting Type 8761 with the Bürkert Communicator software

The Bürkert Communicator software interface is based on CANopen. An appropriate bus termination is mandatory. For Type 8761 Analogue and Industrial Ethernet, Therefore, activate the switchable terminating resistor on the bÜS stick.

Type 8761 Analogue resp. Industrial Ethernet is connected via the device's micro USB socket (USB-bÜS interface set 2 contains the necessary accessories).

Note: no external power supply must be connected to the micro USB socket. The device must be provided with power as described in chapter "5. Product connections" on page 8.

7.3. Configuration management for easy device replacement

If a device needs to be replaced, the memory card can be removed from the defective device and can be inserted into the new device. This transfers all data from the device to be replaced to the new device. The memory card is available as an accessory and must be ordered separately (see "8.3. Ordering chart accessories" on page 12).

In order to successfully exchange the device, it is necessary that both the new device and the device to be replaced have the same article number.

7.4. Web server for Industrial Ethernet variant

All Industrial Ethernet-based devices (except for the EtherCAT® protocol) have an integrated web server. The server can be accessed via a web browser when entering the device's IP address (factory setting IP192.168.1.100).

8. Ordering information

8.1. Bürkert eShop



Bürkert eShop – Easy ordering and quick delivery

You want to find your desired Bürkert product or spare part quickly and order directly? Our online shop is available for you 24/7. Sign up and enjoy all the benefits.

[Order online now](#)

8.2. Bürkert product filter









Bürkert product filter – Get quickly to the right product

You want to select products comfortably based on your technical requirements? Use the Bürkert product filter and find suitable articles for your application quickly and easily.

[Try out our product filter](#)

8.3. Ordering chart accessories

Description	Article number.
General accessories	
USB-büs interface set 2 (Type 8923) for connection to the Bürkert Communicator software: includes büS stick, connection cable to M12 plug, M12 connection cable on micro USB for the büS service interface and Y-distributor, cable length: 0.7 m	772551 
Power supply unit Phoenix Class2 (Type 1573), 85...240 V AC/24 V DC, 1.25 A, NEC Class 2 (UL 1310)	772438 
Power supply unit for standard rail (Type 1573), 100...240 V AC/24 V DC, 1 A, NEC Class 2 (UL 1310)	772361 
Power supply unit for standard rail (Type 1573), 100...240 V AC/24 V DC, 2 A, NEC Class 2 (UL 1310)	772362 
Power supply unit for standard rail (Type 1573), 100...240 V AC/24 V DC, 4 A	772363 
Memory card	On request
Device description files for software interfaces	Download from Type 8761 ▶
Bürkert Communicator software	Download from Type 8920 ▶
For Type 8761 Analogue	
Terminal strip, 6-pin (standard for Type 8761, included in the scope of delivery of the corresponding analogue variant)	On request
D-sub adapter cable, on strand, cable length: 5 m	580882 
D-sub adapter cable, on strand, cable length: 10 m	580883 