



## Digital electropneumatic process controller for integrated mounting on process control valves

- Compact and robust stainless steel design
- Easy start-up via Tune function for position and process controller
- Contact-free position sensor
- Integrated pilot air duct with spring chamber aeration
- PROFIBUS DP-V1, EtherNet/IP, PROFINET, Modbus TCP or bÜS (Bürkert System Bus)

Product variants described in the data sheet may differ from the product presentation and description.

### Can be combined with

	<b>Type 2301</b> Pneumatically operated 2-way Globe Control Valve	▶
	<b>Type 2300</b> Pneumatically operated 2-way angle seat control valve ELEMENT	▶
	<b>Type 2103</b> 2/2-way diaphragm valve with pneumatic stainless steel actuator (Type ELEMENT) for decentralised automation	▶
	<b>Type 8202</b> pH or redox potential transmitter, ELEMENT design	▶
	<b>Type 8045</b> Electromagnetic insertion flowmeter	▶
	<b>Type 8619</b> multiCELL – multi-channel/ multi-function transmitter/ controller	▶
	<b>Type 8228</b> Inductive conductivity meter, ELEMENT Design	▶

### Type description

The compact process controller device Type 8693 is optimised for integrated mounting on the pneumatic actuators in the Type 23xx/2103 process valve series and is specially designed for the requirements of a hygienic process environment. The actual value of the process factor is directly supplied to the device as 4 - 20 mA, PT100 or a frequency signal. The process controller calculates the setpoint for the subordinated positioner based on the variance comparison. Via the analogue feedback, all analogue values on the control levels can be transferred.

The integrated diagnostic functions are used to monitor control valve operating conditions. Valve diagnostic messages via status signals are issued in accordance with NE107 (NAMUR) and recorded as historical entries. The parameterisation of process controller and positioner can be carried out automatically. The easy operation and the selection of additional software functions are carried out either via the large graphic display with backlight and keypad or via COMMUNICATOR.

The positioner registers the valve position without deterioration via a contact-free, analogue position sensor. The actuation of single or double-acting actuators is carried out without internal air consumption. Communication interfaces such as PROFIBUS DP-V1, EtherNet/IP, PROFINET, Modbus TCP, bÜS (based on CANopen) and analogue as well as digital feedback are optionally available.

## Table of contents

<b>1. General technical data</b>	<b>3</b>
<hr/>	
<b>2. Approvals and conformities</b>	<b>5</b>
2.1. General notes .....	5
2.2. Conformity .....	5
2.3. Standards .....	5
2.4. Explosion protection.....	5
2.5. North America (USA/Canada) .....	5
2.6. Others .....	5
China Compulsory Certification (CCC).....	5
<hr/>	
<b>3. Materials</b>	<b>6</b>
3.1. Material specifications .....	6
<hr/>	
<b>4. Dimensions</b>	<b>6</b>
4.1. Multipole version .....	6
4.2. Cable gland version.....	6
4.3. Mounting on control valves of actuator series Type 23xx, actuator size 70/90/130/225 mm.....	7
4.4. Mounting on control valves of actuator series Type 27xx, actuator size 175/225 mm.....	8
<hr/>	
<b>5. Device/Process connections</b>	<b>9</b>
5.1. Electrical connections .....	9
Multipole connection.....	9
Cable gland.....	10
PROFIBUS DP connection.....	10
EtherNet/IP, PROFINET, Modbus TCP connection .....	11
Bürkert system bus (bÜS) connection .....	12
<hr/>	
<b>6. Performance specifications</b>	<b>13</b>
6.1. Signal flow diagram .....	13
Process control circuit .....	13
Position control loop.....	13
Additional software options of the TopControl process controller Type 8693 .....	13
6.2. Interface diagram .....	14
Version without fieldbus communication .....	14
Version with fieldbus communication .....	14
<hr/>	
<b>7. Product installation</b>	<b>15</b>
7.1. Combination options with pneumatic process valves .....	15
<hr/>	
<b>8. Ordering information</b>	<b>16</b>
8.1. Bürkert eShop .....	16
8.2. Bürkert product filter.....	16
8.3. Ordering chart .....	16
8.4. Ordering chart accessories.....	18
Standard accessories .....	18
Adapter kits.....	18

DTS 1000110929 EN Version: AD Status: RL (released | freigegeben | validé) printed: 09.01.2025

## 1. General technical data

Product properties	
Dimensions	Further information can be found in chapter "4. Dimensions" on page 6.
Material	
Body	PPS, stainless steel
Seal	EPDM
Cover	PC
Operation	
Display	Graphic display with backlighting and intuitive menu navigation
Operating keys	Membrane keypad with 4 keys
Service interface	Connected to PC via USB connection
Configuration tool	Bürkert Communicator PACTware (only for device versions with PROFIBUS, resp. analogue version with serial interface)
Commissioning	
Initialisation positioner/process controller	Automatic by P.TUNE function (self-optimisation of PID parameter)
Manual operation of pilot valve	In manual mode via push-button on control panel
Status display	
Display of device and valve status	LEDs (colours according to NAMUR), only valid for Ethernet and bÜS versions
Communication	
Fieldbus	EtherNet/IP, PROFINET, Modbus TCP, PROFIBUS DP-V1
Digital	Bürkert system bus (bÜS) (based on CANopen)
Performance data	
Position sensor	
Measuring principle	Inductive
Position detection module	Contactless analogue position sensor (wear-free)
Stroke range	
Valve spindle	3...45 mm
Electrical data	
Operating voltage	24 V DC $\pm$ 10 % UL: NEC Class 2
Residual ripple	10 %, no technical DC voltage
Power consumption	< 5 W
Protection class	III according to DIN EN 61140 (VDE 0140 - 1)
Input/Output	
Digital input	1 digital input, 0...5 V = log „0“, 10...30 V = log „1“
Digital output	2 digital outputs (optional), galvanically isolated
Current limitation	100 mA, in case of overload, the output is switched off and cyclically switched on again to check for still existing overload.
Analogue output	1 output (optional) 0/4...20 mA, 0...5/10 V
Input data setpoint and actual value	
Setpoint signal	
Setpoint value setting default	0/4...20 mA 0...5/10 V
Input resistance	0/4...20 mA, 180 $\Omega$ 0...5/10 V, 19 k $\Omega$
Setpoint signal	
Setting 4...20 mA	180 $\Omega$ input resistance
Frequency setting	17 k $\Omega$ input resistance, 0...1000 Hz
Setting Pt 100	- 20...+ 220 $^{\circ}$ C, resolution < 0.1 $^{\circ}$ C
Electrical connection	
Multipole version	M12, 8-pin resp. 4-pin or 5-pin according to device version (see "5. Device/Process connections" on page 9)
Cable gland version	2x M16 $\times$ 1.5 (cable $\varnothing$ 5...10 mm) with terminals for cable cross-sections 0.14...1.5 mm <sup>2</sup>

Pneumatic data	
<b>Control medium</b>	<b>Neutral gases, air, quality class according to ISO 8573 - 1</b>
Dust content	Class 7 (< 40 µm particle size)
Particle density	Class 5 (< 10 mg/m <sup>3</sup> )
Pressure dew point	Class 3 (< 20 °C)
Oil content	Class X (< 25 mg/ m <sup>3</sup> )
<b>Air intake filter</b>	<b>Exchangeable</b>
Mesh size	~0.1 mm
<b>Supply pressure</b>	
Low air capacity	0...7 bar <sup>1)</sup>
High air capacity	3...7 bar
Pilot air port	Threaded connection G 1/8, stainless steel
Positioning system	
<b>Low air capacity</b>	
Single-acting and double-acting	7 l <sub>N</sub> /min for aeration and ventilation (Q <sub>Nr</sub> value according to definition at pressure drop from 7 to 6 bar abs)
Actuator series/size	Type 23xx, actuator Ø 70/90 mm
<b>High air capacity</b>	
Single-acting	130 l <sub>N</sub> /min for aeration and ventilation (Q <sub>Nr</sub> value according to definition at pressure drop from 7 to 6 bar abs)
Actuator series/size	Type 23xx, actuator Ø 70/90/225 mm Type 27xx, actuator Ø 175/225 mm
Approvals and conformities	
Explosion protection	
Ignition protection class	II 3D Ex tc IIIC T135 °C Dc II 3G Ex ec IIC T4 Gc
ATEX	BVS 14 ATEX E 008 X II 3D Ex tc IIIC T135 °C Dc II 3G Ex ec IIC T4 Gc
IECEX	IECEX BVS 14.0009 X Ex tc IIIC T135 °C Dc Ex ec IIC T4 Gc
Further information can be found in chapter <b>"2.4. Explosion protection" on page 5.</b>	
North America (USA/Canada)	
UL Listed for the USA and Canada	cULus certificate: E238179 Further information can be found in chapter <b>"2.5. North America (USA/Canada)" on page 5.</b>
FM Explosion Protection	Increased Safety for Class I, Zone 2, AEx ec IIC T4 Gc hazardous (classified) locations, indoors and outdoors (IP54). Alternatively marked as Class I Division 2 Groups A, B, C, and D; T4. Further information can be found in chapter <b>"2.5. North America (USA/Canada)" on page 5.</b>
Others	
China Compulsory Certification (CCC)	The products with Ex approval are suitable for import and use for hazardous applications in China. Further information can be found in chapter <b>"2.6. Others" on page 5.</b>
Further information can be found in chapter <b>"2. Approvals and conformities" on page 5.</b>	
Environment and installation	
Operating conditions	
Ambient temperature	- 10...+ 55 °C
Degree of protection	IP65/IP67 according to EN 60529, 4X according to NEMA 250 Standard
Operating altitude	Up to 2000 m above sea level
Installation and mechanical data	
Installation position	As required, preferably with actuator in upright position
Valve actuator (type, size)	ELEMENT Type 23xx (actuator size Ø 70/90/130/225 mm) CLASSIC Type 27xx (actuator size Ø 175/225 mm)
Adapter kit	Further information can be found in chapter <b>"Adapter kits" on page 18.</b>

1.) The supply pressure applied must be 0.5 to 1 bar above the minimum required pilot pressure of the valve actuator.

## 2. Approvals and conformities

### 2.1. General notes

- The approvals and conformities listed below must be stated when making enquiries. This is the only way to ensure that the product complies with all required specifications.
- Not all available versions can be supplied with the below mentioned approvals or conformities.



### 2.2. Conformity

In accordance with the Declaration of Conformity, the product is compliant with the EU Directives.



### 2.3. Standards

The applied standards which are used to demonstrate compliance with the EU Directives are listed in the EU-Type Examination Certificate and/or the EU Declaration of Conformity.

### 2.4. Explosion protection

Approval	Description
 	<p><b>Optional: Explosion protection</b></p> <p><b>ATEX:</b>                      BVS 14 ATEX E 008 X                      II 3D Ex tc IIIC T135 °C Dc                      II 3G Ex ec IIC T4 Gc</p> <p><b>IECEX:</b>                      IECEX BVS 14.0009 X                      Ex tc IIIC T135 °C Dc                      Ex ec IIC T4 Gc</p>

### 2.5. North America (USA/Canada)

Approval	Description
	<p><b>Optional: UL Listed for the USA and Canada</b></p> <p>The products are UL Listed for the USA and Canada according to:</p> <ul style="list-style-type: none"> <li>• UL 61010-1 (ELECTRICAL EQUIPMENT FOR MEASUREMENT, CONTROL, AND LABORATORY USE – Part 1: General Requirements)</li> <li>• CAN/CSA-C22.2 No. 61010-1</li> </ul>
	<p><b>Optional: FM (Factory Mutual) – Explosion Protection</b></p> <p>Increased Safety for Class I, Zone 2, AEx ec IIC T4 Gc hazardous (classified) locations, indoors and outdoors (IP54). Alternatively marked as Class I Division 2 Groups A, B, C, and D; T4.</p>

### 2.6. Others

#### China Compulsory Certification (CCC)

Conformity	Description
	<p><b>Optional: China Compulsory Certification (CCC)</b></p> <p>The products with Ex approval are suitable for import and use for hazardous applications in China.</p>

DTS 1000110929 EN Version: AD Status: RL (released | freigegeben | validé) printed: 09.01.2025

### 3. Materials

#### 3.1. Material specifications

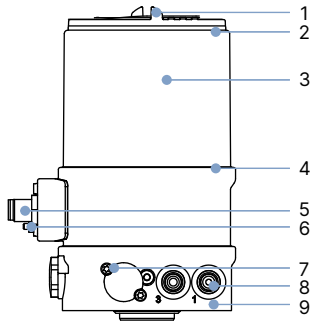

No.	Element	Material
1	Cover	PC
2	Seal	EPDM
3	Body casing	Stainless steel
4	Seal	EPDM
5	M12 plug connector	Stainless steel
6	Screws	Stainless steel
7	Screws	Stainless steel
8	Push-in connector Threaded ports G 1/8	POM/stainless steel Stainless steel
9	Basic housing	PPS

### 4. Dimensions

#### 4.1. Multipole version

**Note:**

Dimensions in mm

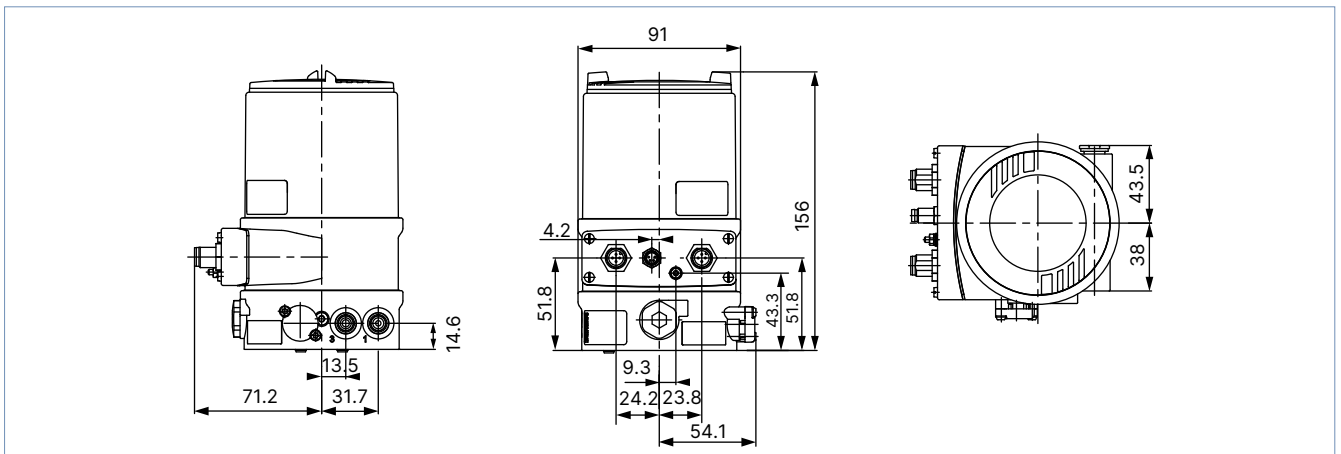

#### 4.2. Cable gland version

**Note:**

Dimensions in mm

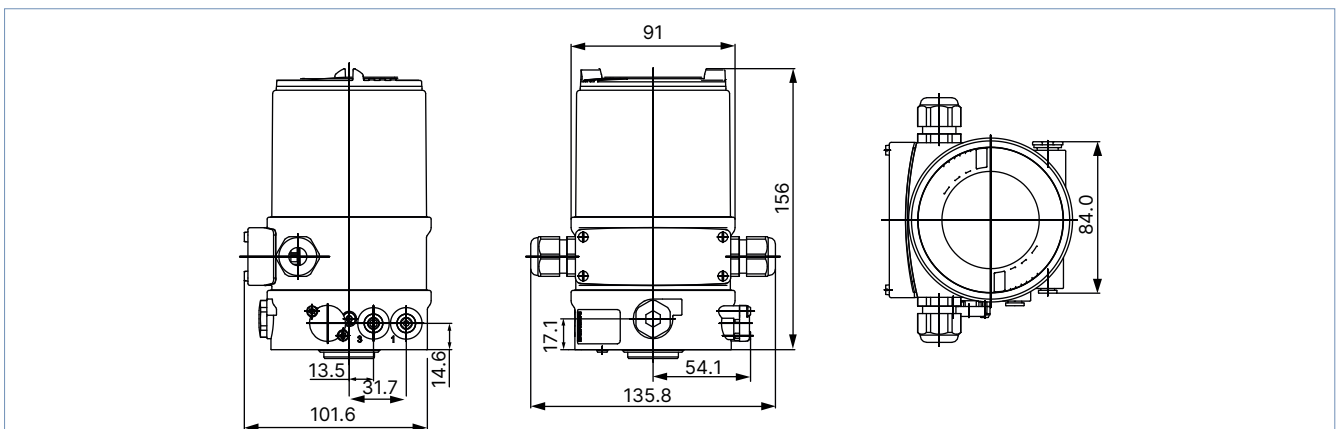

**4.3. Mounting on control valves of actuator series Type 23xx, actuator size 70/90/130/225 mm**

**Note:**

Dimensions in mm

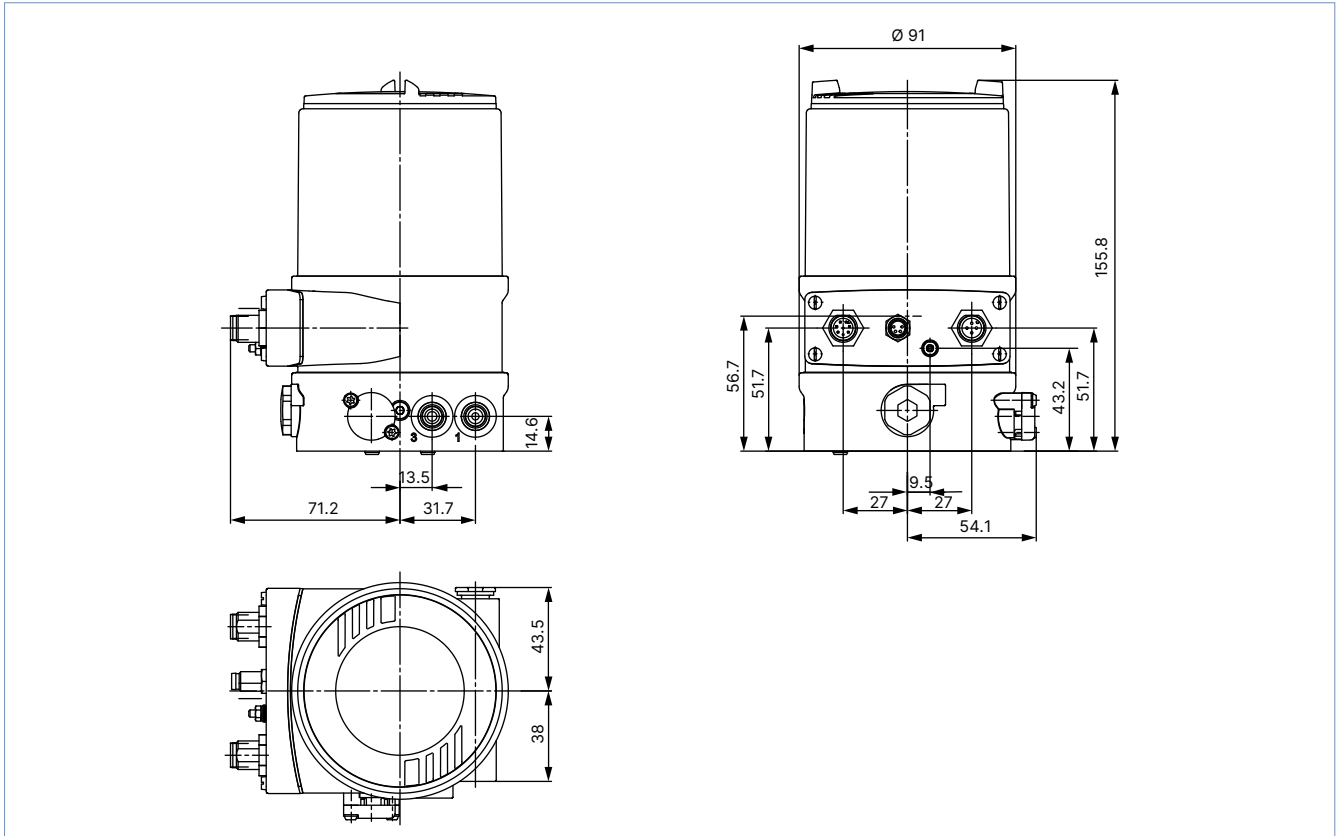

**4.4. Mounting on control valves of actuator series Type 27xx, actuator size 175/225 mm**

**Note:**

Dimensions in mm

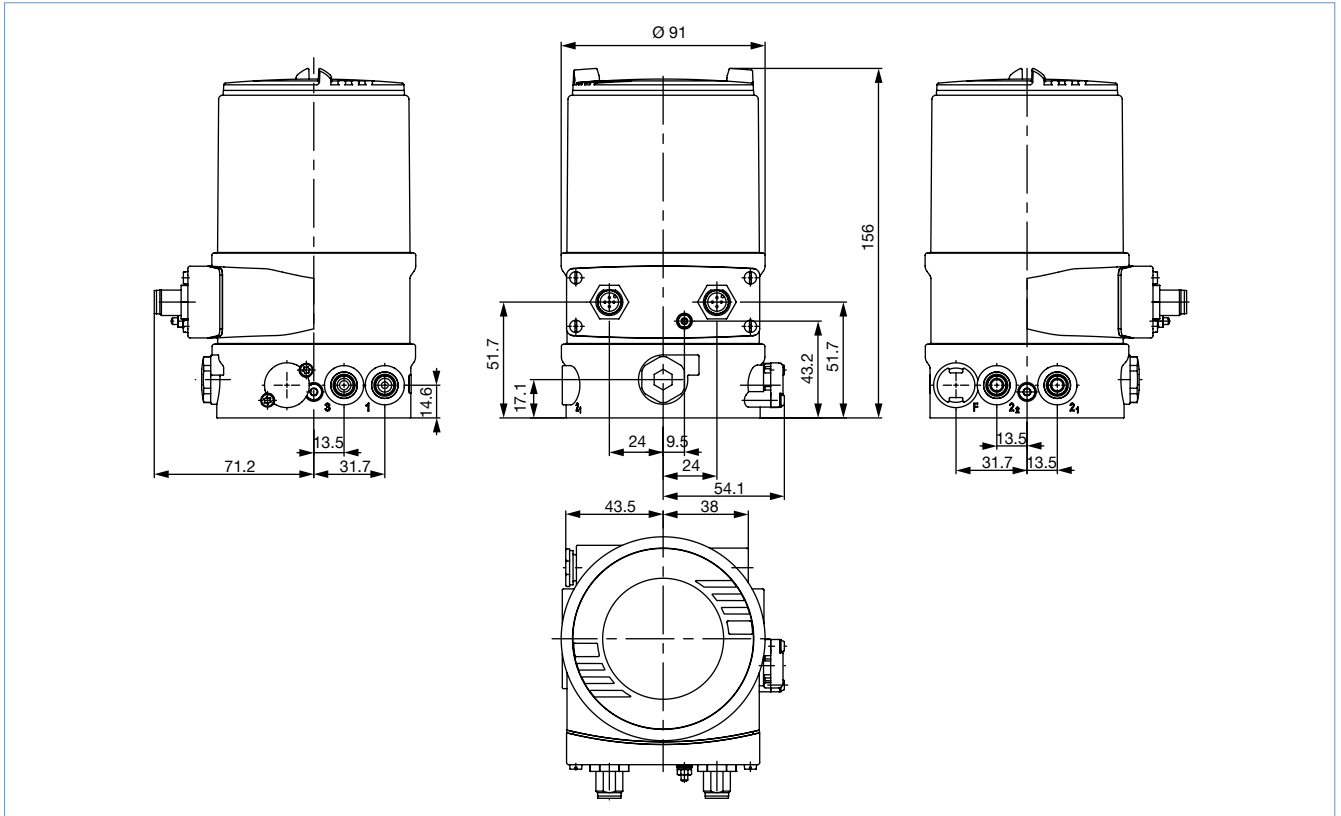

## 5. Device/Process connections

### 5.1. Electrical connections

#### Multipole connection

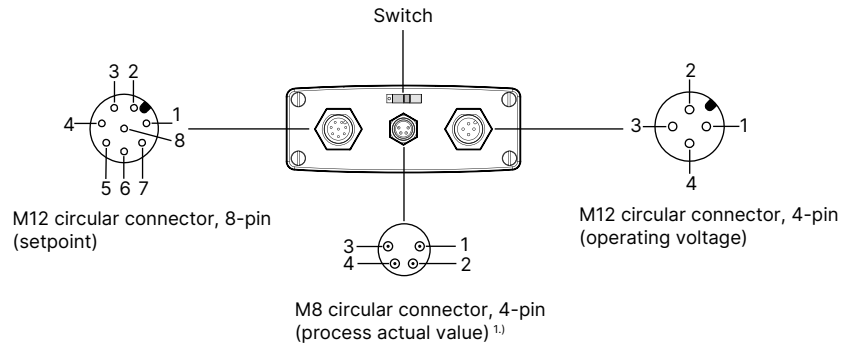

M12 circular plug, 8-pin (setpoint)		M12 circular plug, 8-pin (input/output signal) <sup>1)</sup>		M12 circular plug, 4-pin (operating voltage)	
Pin	Pin assignment	Pin	Pin assignment	Pin	Pin assignment
7	Setpoint GND	1	Digital input +	1	Operating voltage + 24 V DC
8	Setpoint + (0/4...20 mA/0...5/10 V)	2	Digital output GND	2	Not assigned
		3	Digital output 2	3	Operating voltage GND
		4	Digital output 1	4	Not assigned
		5	Analogue feedback GND		
		6	Analogue feedback +		

1.) With the options analogue feedback or digital outputs

#### M8 circular plug, 4-pin (process actual value)

**Note:**

For reasons of wire compensation connect the Pt 100 sensor via 3 wires. Always bridge Pin 3 and Pin 4 on the sensor.

Input type <sup>1)</sup>	Pin	Pin assignment	Switch
4...20 mA, internally supplied	1	+ 24 V Transmitter supply	 Switch on left
	2	Output from transmitter	
	3	GND	
	4	Bridge to GND	
4...20 mA, externally supplied	1	Not assigned	 Switch on right
	2	Process actual value +	
	3	Not assigned	
	4	Process actual value -	
Frequency, internally supplied	1	+ 24 V Sensor supply	 Switch on left
	2	Clock input +	
	3	Clock input - (GND)	
	4	Not assigned	
Frequency, externally supplied	1	Not assigned	 Switch on right
	2	Clock input +	
	3	Clock input -	
	4	Not assigned	
Pt 100 (see note above)	1	Not assigned	 Switch on right
	2	Process actual value 1 (power supply)	
	3	Process actual value 2 (GND)	
	4	Process actual value 3 (compensation)	

1.) With the options analogue feedback or digital outputs

DTS 1000110929 EN Version: AD Status: RL (released | freigegeben | validé) printed: 09.01.2025

Cable gland

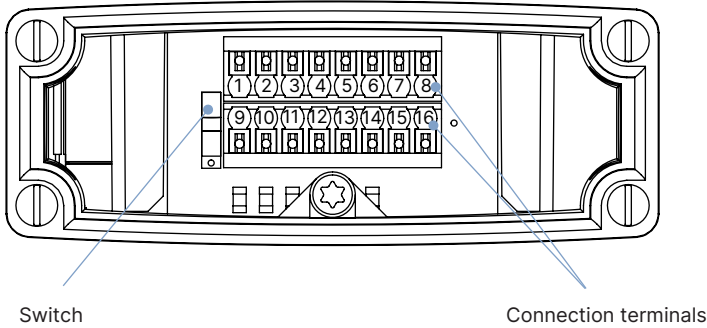

Terminal	Pin assignment
1	Analogue feedback GND
2	Analogue feedback +
3	Digital output GND
4	Digital output 2
5	Digital output 1
6	Digital input +
7	Setpoint GND
8	Setpoint +
9	Process actual value: assignment depends on sensor type, details see <b>operating instructions</b>
10	
11	<b>Type 8693 ▶</b>
12	
13	Not assigned
14	Digital input GND
15	Operating voltage GND
16	Operating voltage + 24 V

PROFIBUS DP connection

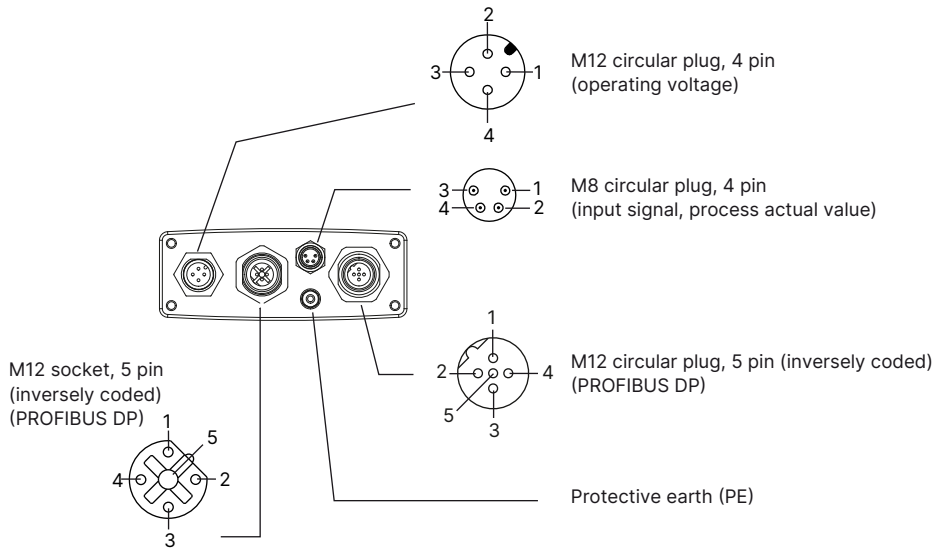

Socket/ M12 circular plug, 5-pin fieldbus connection		M12 circular plug, 4-pin operating voltage		
Pin	Pin assignment	Pin	Wire colour <sup>1)</sup>	Pin assignment
1	VP + 5	1	Brown	Operating voltage + 24 V
2	RxD/TxD-N	2	-	Not assigned
3	DGND	3	Blue	Operating voltage GND
4	RxD/TxD-P	4	-	Not assigned
5	Not assigned			
<b>Thread</b>	Shielding/protective earth			

1.) The specified wire colours refer to the connection cable, which is available as an accessory with Article no. 918038.

**EtherNet/IP, PROFINET, Modbus TCP connection**



M12 circular plug, 4-pin, operating voltage			M12 fieldbus connection, D-coded		Connector diagram
Pin	Wire colour <sup>1.)</sup>	Pin assignment	Pin	Pin assignment	
1	Brown	Operating voltage + 24 V	1	Transmit +	
2	-	Not assigned	2	Receive +	
3	Blue	Operating voltage GND	3	Transmit -	
4	-	Not assigned	4	Receive -	

1.) The specified wire colours refer to the connection cable, which is available as an accessory with Article no. 918038.

DTS 1000110929 EN Version: AD Status: RL (released | freigegeben | validé) printed: 09.01.2025

**M8 circular plug, 4-pin (input signal for process actual value)**

**Note:**

For reasons of wire compensation, connect the Pt 100 sensor via 3 wires. Always bridge Pin 3 and Pin 4 on the sensor.

Input type <sup>1)</sup>	Pin	Wire colour <sup>2)</sup>	Pin assignment	Switch	Outer circuitry
4...20 mA - internally supplied	1	Brown	+ 24 V Transmitter supply	<p>Switch on left</p>	
	2	White	Output from transmitter		
	3	Blue	GND (identical to GND operating voltage)		
	4	Black	Bridge according to GND (GND from 3 guide transmitter)		
4...20 mA - externally supplied	1	Brown	Not assigned	<p>Switch on right</p>	
	2	White	Process actual value +		
	3	Blue	Not assigned		
	4	Black	Process actual value -		
Frequency - internally supplied	1	Brown	+ 24 V sensor supply	<p>Switch on left</p>	
	2	White	Clock input +		
	3	Blue	Clock input - (GND)		
	4	Black	Not assigned		
Frequency - externally supplied	1	Brown	Not assigned	<p>Switch on right</p>	
	2	White	Clock input +		
	3	Blue	Clock input -		
	4	Black	Not assigned		
Pt 100 (see note above)	1	Brown	Not assigned	<p>Switch on right</p>	
	2	White	Process actual value 1 (power supply)		
	3	Blue	Process actual value 3 (GND)		
	4	Black	Process actual value 2 (compensation)		

1.) Can be adjusted via software (see **operating instructions Type 8692/8693** ▶ "24.2.1 PV-INPUT – Setting up the process controller")  
 2.) The specified wire colours refer to the connection cable, which is available as an accessory with Article no. 264602.

**Bürkert system bus (bùS) connection**

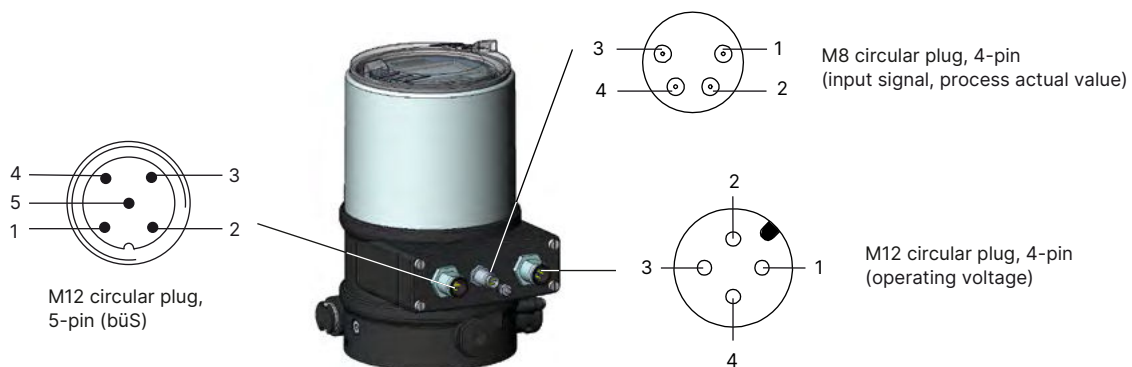

M12 circular plug × 1, 5-pin (bùS connection)			M12 circular plug, 4-pin (operating voltage)		
Pin	Wire colour	Pin assignment	Pin	Wire colour <sup>1)</sup>	Pin assignment
1	CAN shielding	CAN shielding	1	Brown	Operating voltage + 24 V DC
2	-	Not assigned	2	-	Not assigned
3	Black	GND / CAN_GND	3	Blue	Operating voltage GND
4	White	CAN_H	4	-	Not assigned
5	Blue	CAN_L			

1.) The specified wire colours refer to the connection cable, which is available as an accessory with Article no. 918038.

## 6. Performance specifications

### 6.1. Signal flow diagram

#### Process control circuit

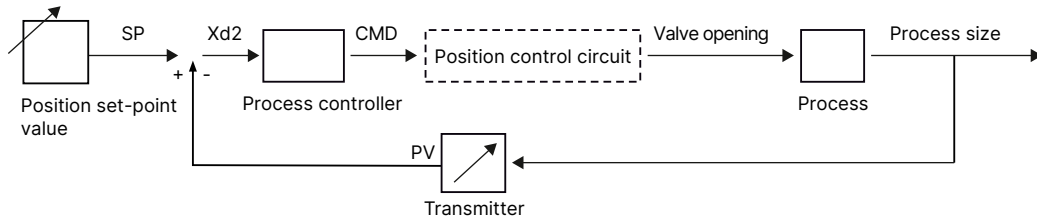

#### Position control loop

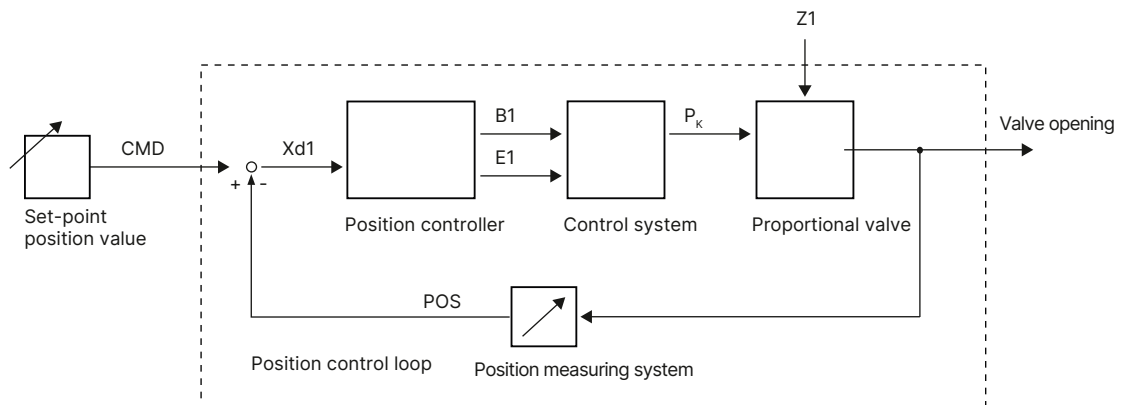

#### Additional software options of the TopControl process controller Type 8693

- Automatic commissioning of control valve systems
- Automatic parameterisation of process control circuit
- Automatic or manual characteristic curves selection
- Setting of seal and maximum stroke threshold, respectively
- Parameterisation of positioner
- Manual parameterisation of process controller
- Limitation of stroke range
- Limitation of positioning speed
- Setting direction of movement
- Configuration of digital input
- Signal range splitting on several controllers
- Configuration of 1 analogue or 2 digital outputs
- Signal fault detection
- Safety position
- Code protection
- Contrast inversion of display
- Language selection
- Parameterisable diagnostic functions<sup>1)</sup> / digital outputs (option)
  - Operating hours counter
  - Path accumulator
  - Monitoring of process actual value
  - Position monitoring
  - Monitoring of mechanical end positions in the armature

- Graphical display of dwell time density and movement range
- Direction-reversal counter
- Temperature monitoring

1.) Further information on each diagnostic function with detailed description can be found in the **operating instructions Type 8693** ▶

## 6.2. Interface diagram

### Version without fieldbus communication

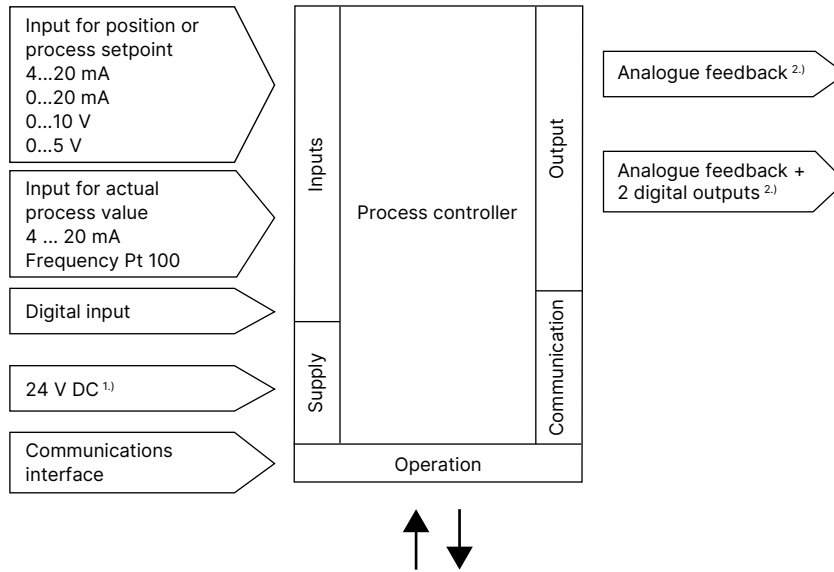

### Version with fieldbus communication

With PROFIBUS DP, EtherNet/IP, PROFINET, Modbus TCP and Bürkert system bus (büS)

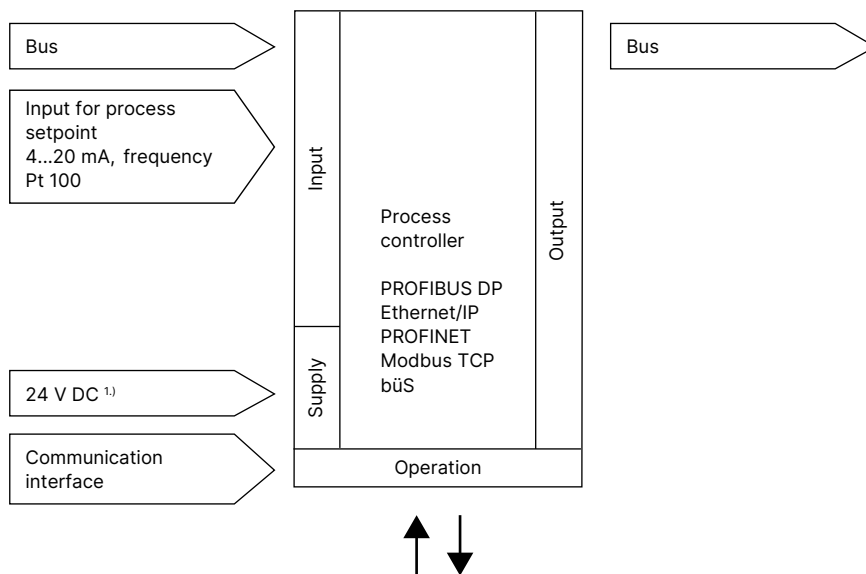

1.) The operating voltage is supplied with a 3-wire unit independent from the setpoint signal.  
 2.) Alternative options

DTS 1000110929 EN Version: AD Status: RL (released | freigegeben | validé) printed: 09.01.2025

## 7. Product installation

### 7.1. Combination options with pneumatic process valves

**Note:**

A **TopControl control valve system** consists of a **process controller Type 8693** and an **ELEMENT control valve Type 23xx**, resp. **Type 2103**.

The following information is required to select a complete system:

- **Article no.** of the desired **process controller TopControl**, see **data sheet Type 8693**
- **Article no.** of the desired **control valve Type 23xx / 2103**, see **data sheet Type 2301 ▶**, **Type 2300 ▶** and **Type 2103 ▶**

You order two components and receive a completely assembled and tested valve.

#### Example of variations of the control valve system



1.) See data sheet **Adaptations for third-party actuators Type KK01 ▶** or contact the appropriate Bürkert sales office.

DTS 1000110929 EN Version: AD Status: RL (released | freigegeben | valide) printed: 09.01.2025

## 8. Ordering information

### 8.1. Bürkert eShop



**Bürkert eShop – Easy ordering and quick delivery**

You want to find your desired Bürkert product or spare part quickly and order directly? Our online shop is available for you 24/7. Sign up and enjoy all the benefits.

[Order online now](#)

### 8.2. Bürkert product filter



**Bürkert product filter – Get quickly to the right product**

You want to select products comfortably based on your technical requirements? Use the Bürkert product filter and find suitable articles for your application quickly and easily.

[Try out our product filter](#)

### 8.3. Ordering chart

**Note:**

- All standard versions are UL-approved.
- The following applies to all of the following variants: pilot air port socket connection G 1/8.

Circuit function Pilot valve system	Communication	Electrical connections	Analogue feedback 0/4...20 mA	Analogue feedback 0/4...20 mA + 2 digital outputs	Diagnos- tics <sup>1)</sup>	Digital input	Article no.	
							Standard	ATEX II Cat. 3G/D, IECEx, CCC <sup>2)</sup>
<b>Actuator series Type 23xx, actuator size Ø 70/90 mm</b>								
Low air capacity, single-acting	Without fieldbus communication	Cable gland	–	–	–	Yes	306936	306990
			–	Yes	Yes	Yes	306965	306991
	PROFIBUS DP-V1	M12 plug connector	–	–	–	Yes	307082	307103
			–	Yes	Yes	Yes	307105	307104
			Via bus	–	–	–	311800	311801
	EtherNet/IP	Via bus	Yes	Yes	–	306867	306865	
	PROFINET	Via bus	Yes	Yes	–	306871	306869	
Modbus TCP	Via bus	Yes	Yes	–	306876	306874		
Bürkert system bus (bÜS)	M12 plug connector	Via bus	–	Yes	–	306881	306878	
Low air capacity, double-acting	Without fieldbus communication	Cable gland	–	–	–	Yes	306931	306992
			–	Yes	Yes	Yes	306994	306993
	PROFIBUS DP-V1	M12 plug connector	–	–	–	Yes	307107	307109
			–	Yes	Yes	Yes	307108	307110
			Via bus	–	–	–	311802	311803

DTS 1000110929 EN Version: AD Status: RL (released | freigegeben | validé) printed: 09.01.2025

Circuit function Pilot valve system	Communication	Electrical connections	Analogue feedback 0/4...20 mA	Analogue feedback 0/4...20 mA + 2 digital outputs	Diagnos- tics <sup>1.)</sup>	Digital input	Article no.	
							Standard	ATEX II Cat. 3G/D, IECEx, CCC <sup>2.)</sup>
<b>Actuator series Type 23xx, actuator size Ø 130/225 mm</b>								
High air capacity, single-acting	Without fieldbus communication	Cable gland	-	-		Yes	306946	306995
			-	Yes	Yes	Yes	306973	306997
	M12 plug connector	-	-	-		Yes	307112	307114
			-	Yes	Yes	Yes	307113	307115
		PROFIBUS DP-V1	Via bus	-	-	-	311804	311805
		EtherNet/IP	Via bus	-	Yes	-	306868	306866
		PROFINET	Via bus	-	Yes	-	306872	306870
		Modbus TCP	Via bus	-	Yes	-	306877	306875
Bürkert system bus (bÜS)	Via bus	-	Yes	-	306882	306880		
<b>Actuator series Type 27xx, actuator size Ø 175/225 mm</b>								
High air capacity, single-acting	Without fieldbus communication	Cable gland	-	-		Yes	306950	307003
			-	Yes	Yes	Yes	306952	307004
	M12 plug connector	-	-	-		Yes	307068	307121
			-	Yes	Yes	Yes	307070	307122
		PROFIBUS DP-V1	Via bus	-	-	-	233356	265138
		EtherNet/IP	Via bus	-	Yes	-	313276	313275
		PROFINET	Via bus	-	Yes	-	313269	313268
		Modbus TCP	Via bus	-	Yes	-	313271	313270
Bürkert system bus (bÜS)	Via bus	-	Yes		313283	313282		

1.) See "Additional software options of the TopControl process controller Type 8693" on page 13

2.) CCC (China Compulsory Certificate) for device versions with Ex approval

**Further versions on request**



**Additional**













EtherNet/IP, PROFINET, Modbus TCP and bÜS (Bürkert System Bus): double-acting versions with low air capacity

## 8.4. Ordering chart accessories

### Standard accessories

**Note:**

Must be ordered separately.



Description	Article no.
M12 circular socket with cable, 8-pin, cable length: 5 m, for input and output signals	919267 
M12 circular socket with cable, 4-pin, cable length: 5 m, for power supply (without communication)	918038 
M8 circular socket with cable, 4-pin, cable length: 5 m, for process actual value of sensor	264602 
USB bÜS interface set 2 (Type 8923) for connection to the Bürkert Communicator software: including bÜS stick, connection cable to M12 plug, M12 connection cable on micro USB for the bÜS service interface and Y distributor, cable length: 0.7 m	772551 
bÜS cable extension, M12, cable length: 1 m	772404 
bÜS cable extension, M12, cable length: 3 m	772405 
bÜS cable extension, M12, cable length: 5 m	772406 
bÜS cable extension, M12, cable length: 10 m	772407 
Silencer G 1/8	780779 
Sensor puck (spare part)	682240 
USB interface for serial communication	227093 
Bürkert Communicator Software	<b>Type 8920</b> 

### Adapter kits

**Note:**

Must be ordered separately.

Adapter kits for third-party actuators can be found in the [data sheet Adaptation for third-party actuators Type KK01](#)  or contact the appropriate Bürkert sales office.

Description	Actuator size	Control function	Article no.
Attachment kit for Type 21xx/23xx actuator series	Ø 70/90/130 mm	Universal	679917 
Attachment kit for Type 21xx/23xx actuator series	Ø 225 mm	Universal	60025906 
Attachment kit for Type 27xx actuator series	Ø 175/225 mm	A (NO), B (NC)	679935 