

**Electric thrust actuator ARI-PACO® 0,85 D/Y****Electric thrust actuator  
ARI-PACO® 0,85 D  
0,85 kN****Input signal:**

- 3-point

**Optional:**

- Potentiometer
- Additional limit switches

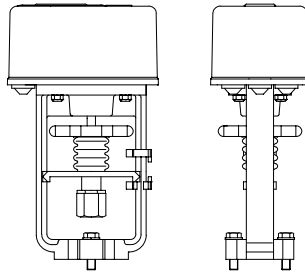

Page 2

**Electric thrust actuator  
ARI-PACO® 0,85 Y  
0,85 kN****Input signal:**

- 0-10V or 2-10V
- Position transmitter
- Start-up with automatic initialisation

**Optional:**

- Potentiometer
- Switch board

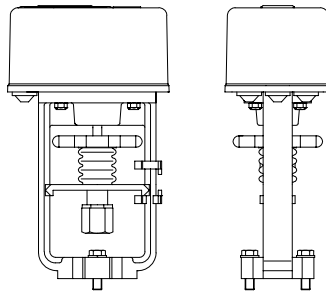

Page 2

**Features:**

- Torque-dependent switching off
- Handwheel
- Operative ambient temperature 0°C to +50°C
- Enclosure IP 54
- Additional devices available, e.g. potentiometer
- Travel indicator

## Electric thrust actuator ARI-PACO® 0,85kN

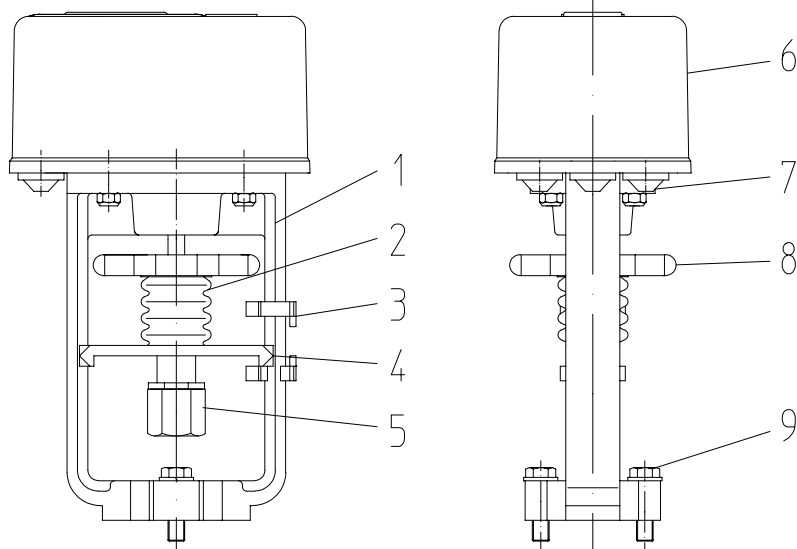

Pos.	Description
1	Yoke
2	Bellow
3	Travel indicator
4	Torsion safety feature
5	Coupling
6	Hood
7	Cable conduit fitting
8	Handwheel
9	Hexagon-head screw M8

Type		ARI-PACO 0,85 D	ARI-PACO 0,85 Y
Thrust force	(kN)	0,85	
Control speed	(mm/s)	0,11	
Travel max.	(mm)	20	
Operation mode		S3 50% ED	
Motor voltage ( ±10% )	(V / Hz)	230V - 50 / 60Hz *	24V - 50 / 60Hz *
Power consumption	(VA)	4,1	4,8
Enclosure	DIN VDE 0470	IP 54	
Max. permissible ambient temperature		0 °C ... +50 °C	
Top mounted handwheel		Changeover switch and handwheel	
Control signal (input)		3-point	0 (2) - 10 V DC (invertable, max. 0,5 mA)
Feedback signal		--	0 - 10 V DC (invertable, max. 5 mA)
Mounting position		Horizontally to vertical above the valve body (any position 90° from vertical)	
Stem lubricant		Klüber: Microlube GB	
Weight	(kg)	1,3	

\* Control speed and power consumption are 20% higher at frequency of 60 Hz.

Accessories	ARI-PACO 0,85 D	ARI-PACO 0,85 Y
Additional limit switches	2 changeover contacts, zero-potential, switching capacity 3A, 250 V~	--
Switch board (optional as 2 add. limit switches or 1 error message switch usable)	--	2 changeover contacts, zero-potential, switching capacity 3A, 250 V~
Potentiometer	1 piece - 1000 Ohm	1 piece - 1000 Ohm (alternative to switch board)
Additional voltages / frequencies	24V - 50Hz / 60Hz*	--

\* Control speed and power consumption are 20% higher at frequency of 60 Hz.

### 1. Automatic travel adaption

In a manual started initialisation run the real valve travel is determined and the control- and the feedback-signals are automatically adjusted. The initialisation run is indicated optical and mechanical. With deactivated voltage limitation the initialisation run is additionally indicated by a 13 Volt feedback signal.

### 2. Direct control open/stop/close

A priority sequence ensures, that the manual-mode switch of the actuator has always the highest priority before the following direct control and at last the automatic mode. This function guarantees the correct working of the actuator in every operating situation. The direct connection of the frost protection switch without cutting-off the control signal from the actuator is enabled to be done by this function.

### 3. Manual-mode switching

For safety reasons the actuator is automatically switched in the manual mode by removing the hood. In this mode the actuator doesn't obey the automatic control signal or the direct control signal. To get the function checked during the installation, the actuator can be switched back in the automatic mode by an internal magnetic switch.

With deactivated voltage limitation the manual mode is indicated by a 13 Volt feedback signal.

### 4. Variable control- and feedback-signals

The range of the control signal can be switched from 0...10V to 2...10V and also be inverted to 10...0V or 10...2V. The feedback signal 0...10V can also be inverted to 10...0V. If the voltage limitation is deactivated error messages and some specific working modes of the actuator are signalised by a 13V feedback signal.

### 5. Wearless actual value sensing

The value of the actual valve position is calculated from wearless sensed signals of a reed contact, which is mounted on the motor shaft. Trouble-free durability of the actuator is ensured by this construction.

### 6. Non contact motor travel switching

The travel switching in the final positions is done electronically, when the number of counts to get the nominal thrust force is reached. This function also ensures the trouble-free durability of the actuator.

### 7. Switchable valve blocking-protection

Dependent on the plant process it is possible to activate the valve blocking-protection. In the activated mode the valve is opened for a short time, after every 24 hours in a closing position without any movements, to protect the soft sealing against sticking to the valve seat.

### 8. Automatic valve blocking signalling and removing

If a valve blocking is detected, the actuator tries automatically to eliminate the blocking by means of different moving commands. With deactivated voltage limitation this function is indicated by a 13 Volt feedback signal.

### 9. Dynamic hysteresis

Interferences on the control signal lines are suppressed by the dynamic hysteresis automatically. By this means the actuator and the valve is protected against unnecessary movements and in consequence unnecessary wear and shorter lifetime.

### 10. Zero crossing

By connecting the neutral lines of the DC control signal and the AC power input, the economic 3-wire-connection is realised. To minimise errors caused by voltage drops of long wires on the control signal Y, the control signal Y is only read in the zero crossing.



### Function and error indication ARI-PACO 0,85 Y

Working mode	Indication of the LED		Feedback signal
Automatic mode	_____	LED lit constantly	0 ... 10 V DC (between connector A and 0)
Initialisation runs	-----	LED blinking regular Handwheel is running with short stops	10 V DC (between connector A and 0) With deactivated voltage limitation 13 V DC
Valve blocking	_____	LED blinking irregular (until new initialisation is done)	
Manual mode (after manual operation a particular initialisation will be processed)	_____	LED lit constantly	

**ARI-PACO® 0,85 D**

Standard

Accessories

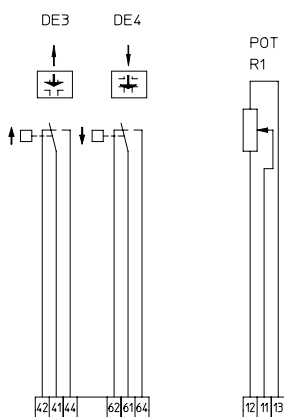
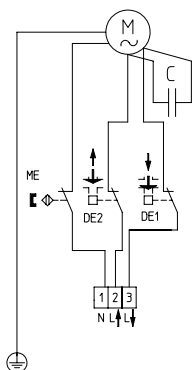

DE	Torque switch
POT	Potentiometer
C	Capacitor
M	Motor
ME	Magnetic switch

**ARI-PACO® 0,85 Y**

Standard

Accessories

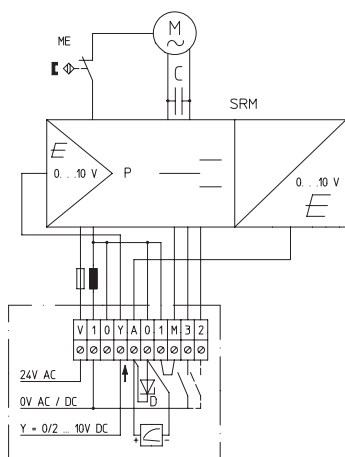

1. Function

2. Function (message switch)

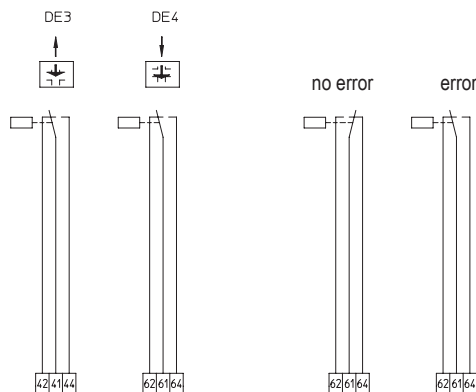

DE	Torque switch
C	Capacitor
M	Motor
ME	Magnetic switch
SRM	Positioncontroller, -indicator
D	Zener diode for voltage limitation

With input signals 0/2-10 V a bridge, connecting the terminals 1 and M, has to be installed. A signal at the terminals 2 and 3 e.g. from an anti-freezing contact has always priority over the input signal. For automatic operation, a jumper 1/M must be installed, the priority switching is preserved. In case of a three-step controller signal the bridge is not required.

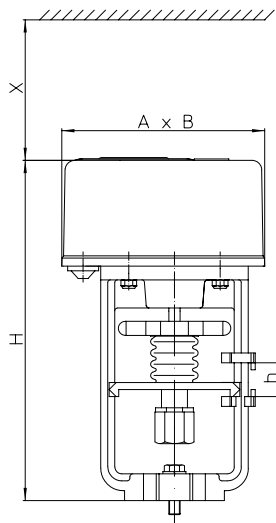
**0,85 kN**

Travel 3 ... 20 mm

		0,85 kN
A	(mm)	145
B	(mm)	95
X	(mm)	100
H	(mm)	242
h (nominal travel)	(mm)	max. 20