







Manually operated 2/2-way globe valve

- Compact design
- Long service life
- Robust actuator with optional stroke limitation and locking
- Stainless steel valve body with socket, clamp or welded connection

Product variants described in the data sheet may differ from the product presentation and description.

Can be combined with

	Type 2101 Pneumatically operated 2/2-way globe valve ELEMENT for decentralised automation	▶
	Type 2100 Pneumatically operated 2/2-way angle seat valve ELEMENT for decentralized automation	▶
	Type 2920 Manually operated 2/2-way angle seat valve	▶
	Type 2961 Manually operated 2-way globe control valve	▶
	Type 8801 On/off valve systems ELEMENT with decentralised automation – overview	▶
	Type 8840 Modular process valve cluster – distributor and collector	▶

Type description

The Type 2921 globe valve consists of a manual actuator and a 2-way body made of stainless steel. With a high-quality valve body, the manually operated valve offers diverse usage options to shut off both neutral and aggressive gaseous and liquid media. The tried-and-tested self-adjusting packing gland guarantees optimal tightness and therefore enables low-maintenance operation, even at high switching cycles. Depending on the application, the soft PTFE or PEEK seal ensures a reliable valve seat seal, even under challenging operating conditions.

The actuator is made of high-quality plastic and is suitable for use in demanding environments. It possesses a visual position indicator and can be optionally equipped with stroke limitation and locking.

Table of contents

1. General technical data	3
<hr/>	
2. Approvals and conformities	4
2.1. General notes	4
2.2. Conformity	4
2.3. Standards	4
2.4. Explosion protection.....	4
2.5. Drinking water	4
2.6. Foods and beverages/Hygiene	5
<hr/>	
3. Materials	6
3.1. Bürkert resistApp	6
3.2. Material specifications	6
<hr/>	
4. Dimensions	7
4.1. Actuator	7
4.2. Body with flange connection	8
4.3. Body with threaded connection.....	9
4.4. Body with welded connection	10
4.5. Body with clamp connection	11
<hr/>	
5. Performance specifications	12
5.1. Fluidic data.....	12
Overview of fluidic data for flow below seat (for liquids, steam and gases)	12
5.2. Operating limits	13
Operating limits for medium temperature and operating pressure	13
Operating limits for optional variants	13
<hr/>	
6. Product design and assembly	14
6.1. Product features	14
<hr/>	
7. Ordering information	15
7.1. Bürkert eShop	15
7.2. Bürkert product filter	15
7.3. Bürkert Product Enquiry Form	15
7.4. Ordering chart accessories.....	15
Standard accessories	15

DTS 1000599141 EN Version: E Status: RL (released | freigegeben | valide) printed: 22.12.2025

1. General technical data

Product properties	
Dimensions	Further information can be found in chapter "4. Dimensions" on page 7.
Material	Further information can be found in chapter "3. Materials" on page 6.
Design	Globe valve on/off
Nominal diameter	DN 10...DN 100, NPS ¾...NPS 4
Flow direction	Flow to open (below seat)
Performance data	
Operating pressure	0 bar(g)...25 bar(g) (see "5.1. Fluidic data" on page 12)
Nominal pressure	PN 25 (DIN EN 1333), Class 150 (DIN EN 1759)
Seat leakage	Leakage rate A (DIN EN 12266 - 1), seat seal PTFE and PEEK, test medium air (see "5.1. Fluidic data" on page 12)
K _v value	0.1 m ³ /h...140 m ³ /h (see "5.1. Fluidic data" on page 12)
Medium data	
Operating medium	Steam, water, neutral gases, alcohols, oils, fuels, hydraulic fluids, salt solutions, alkalis, organic solvents
Medium temperature	- 40 °C...+ 230 °C (see "5.2. Operating limits" on page 13)
Viscosity	Max. 600 mm ² /s
Product connections	
Port connection ¹⁾	
Threaded connection	G (DIN ISO 228 - 1) NPT (ASME B1.20.1) RC (ISO 7 - 1)
Welded connection	DIN EN ISO 1127 / ISO 4200 / DIN 11866 series B DIN 11850 - 2 / DIN 11866 series A ASME BPE / DIN 11866 series C SMS 3008
Clamp connection	DIN 32676 series B (pipe: ISO 4200) DIN 32676 series A (pipe: DIN 11850 - 2) ASME BPE
Approvals and conformities	
Further information can be found in chapter "2. Approvals and conformities" on page 4	
Environment and installation	
Ambient temperature	- 10 °C...+ 60 °C
Installation position	As required, preferably with actuator upright

1.) Further variants are available on request.

2. Approvals and conformities

2.1. General notes

- The approvals and conformities listed below must be stated when making enquiries. This is the only way to ensure that the product complies with all required specifications.
- Not all available variants can be supplied with the below mentioned approvals or conformities.

2.2. Conformity



In accordance with the Declaration of Conformity, the product is compliant with the EU Directives. This includes the following directives:

- Pressure Equipment Directive 2014/68/EU

2.3. Standards

The applied standards which are used to demonstrate compliance with the EU Directives are listed in the EU-Type Examination Certificate and/or the EU Declaration of Conformity.

2.4. Explosion protection



Approval	Description																
 	<p>Optional: Explosion protection (valid for the variable code PX51) As a category 2 device suitable for zone 1/21 and zone 2/22.</p> <p>ATEX: EPS 18 ATEX 2 008 X II 2G Ex h IIC T4...T2 Gb II 2D Ex h IIIC T135 °C...T300 °C Db</p> <p>IECEx: IECEx EPS 18.0007X Ex h IIC T4...T2 Gb Ex h IIIC T135 °C...T300 °C Db</p> <table border="1"> <thead> <tr> <th>Temperature class</th> <th>T2</th> <th>T3</th> <th>T4</th> </tr> </thead> <tbody> <tr> <td>Maximum surface temperature</td> <td>+ 300 °C</td> <td>+ 200 °C</td> <td>+ 135 °C</td> </tr> <tr> <td>Ambient temperature</td> <td>- 40...+ 130 °C</td> <td>- 40...+ 130 °C</td> <td>- 40...+ 100 °C</td> </tr> <tr> <td>Maximum medium temperature</td> <td>+ 285 °C</td> <td>+ 185 °C</td> <td>+ 125 °C</td> </tr> </tbody> </table> <p>Note: The ambient and medium temperature range may be limited by non-ex-relevant specifications. Observe the Operating Instructions.</p>	Temperature class	T2	T3	T4	Maximum surface temperature	+ 300 °C	+ 200 °C	+ 135 °C	Ambient temperature	- 40...+ 130 °C	- 40...+ 130 °C	- 40...+ 100 °C	Maximum medium temperature	+ 285 °C	+ 185 °C	+ 125 °C
Temperature class	T2	T3	T4														
Maximum surface temperature	+ 300 °C	+ 200 °C	+ 135 °C														
Ambient temperature	- 40...+ 130 °C	- 40...+ 130 °C	- 40...+ 100 °C														
Maximum medium temperature	+ 285 °C	+ 185 °C	+ 125 °C														

2.5. Drinking water

Conformity	Description
	<p>Suitable for use in drinking water applications The materials comply with the assessment principles (UBA) for materials in contact with drinking water (TrinkwasserV).</p> <p>Stainless steel body PF39: Suitable for products with medium temperature up to 85 °C (hot water)</p>

DTS 1000599141 EN Version: E Status: RL (released | freigegeben | valide) printed: 22.12.2025

2.6. Foods and beverages/Hygiene

Conformity	Description
FDA	FDA – Code of Federal Regulations (valid for the variable code PL02) All wetted materials are compliant with the Code of Federal Regulations published by the FDA (Food and Drug Administration, USA) according to the manufacturer’s declaration.
USP	United States Pharmacopeial Convention (USP) (valid for the variable code PL04) All wetted materials are biocompatible according to the manufacturer’s declaration.
	EC Regulation 1935/2004 of the European Parliament and of the Council (valid for the variable code PL01, PL02) All wetted materials are compliant with EC Regulation 1935/2004/EC according to the manufacturer’s declaration.
	China food GB Standards of the People’s Republic of China (valid for the variable code PL10) All wetted materials are compliant with the requirement of China food GB Standards according to the manufacturer’s declaration.

DTS 1000599141 EN Version: E Status: RL (released | freigegeben | valide) printed: 22.12.2025

3. Materials

3.1. Bürkert resistApp



Bürkert resistApp – Chemical resistance chart

You want to ensure the reliability and durability of the materials in your individual application case? Verify your combination of media and materials on our website or in our resistApp.

[Start chemical resistance check](#)

3.2. Material specifications

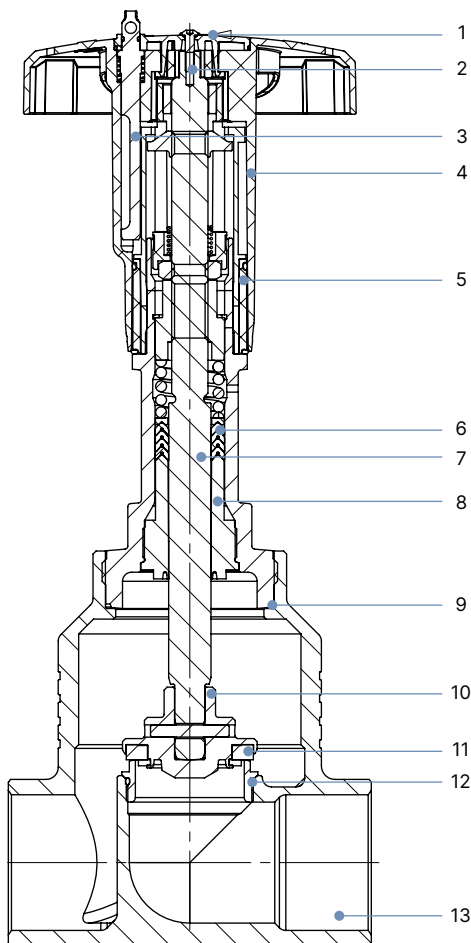

Nr.	Element	Werkstoff
1	Cover	Polyamide (PA)
2	Screw	Stainless steel 1.4301
3	Locking device	Stainless steel 1.4305
4	Handwheel	Polyphenylene sulphide (PPS)
5	Visual position indicator with scale	Polyamide (PA)
6	Packing gland	PTFE V-rings (filled), with spring compensation
7	Spindle	Stainless steel 1.4401 (316)/1.4404 (316L)
8	Spindle guide	DN 15...DN 50: PEEK DN 65...DN 100: Stainless steel 1.4401 (316)/1.4404 (316L)
9	Housing seal	Graphite
10	Swivel plate	Stainless steel 1.4401 (316)/1.4404 (316L)
11	Seat seal	PTFE or PEEK
12	Valve seat with O-ring	Stainless steel 1.4571, EPDM
13	Valve body	Stainless steel 316L/CF3M

DTS 1000599141 EN Version: E Status: RL (released | freigegeben | valide) printed: 22.12.2025

4. Dimensions

4.1. Actuator

Note:

Dimensions in mm, unless otherwise stated

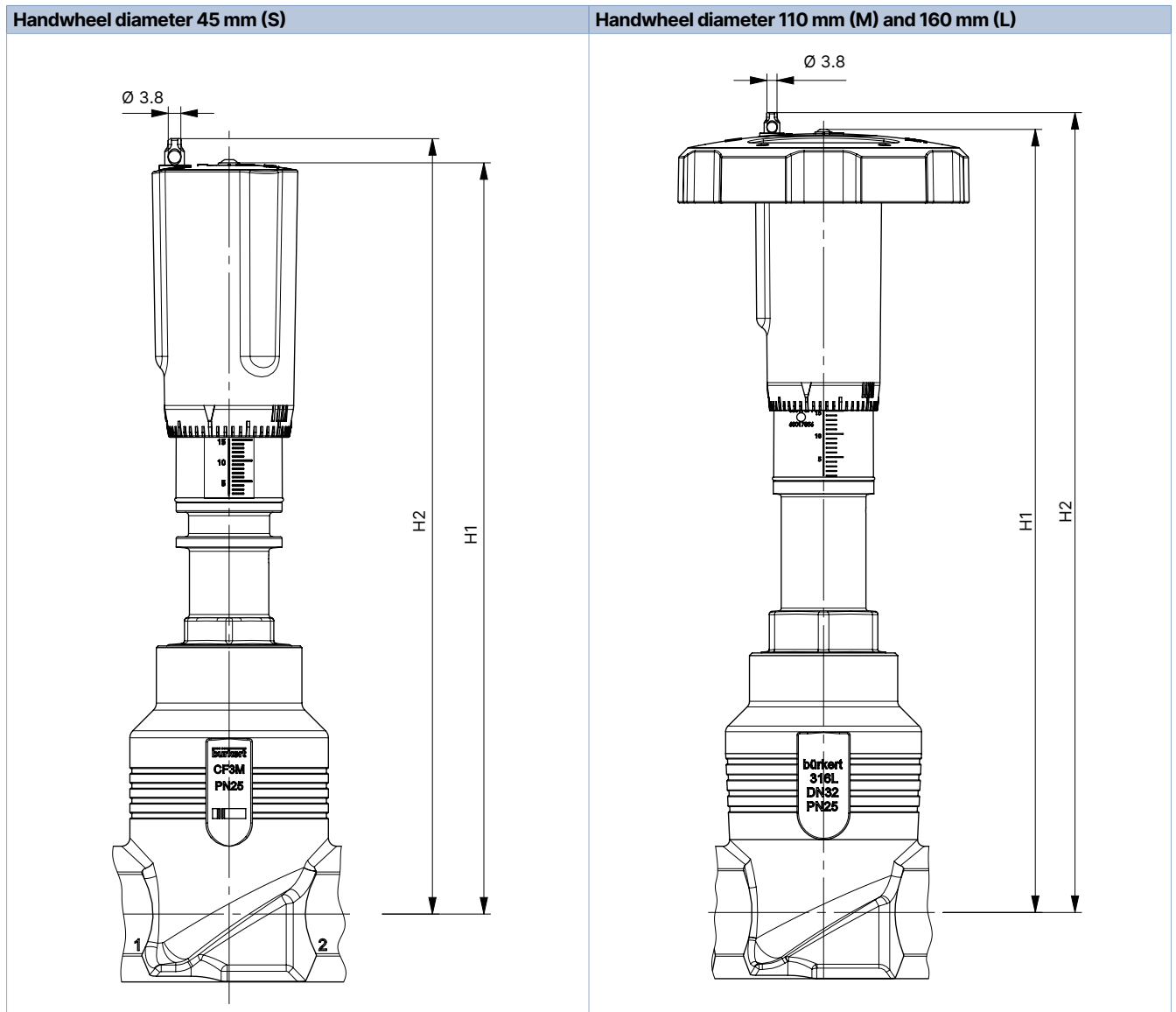

Nominal connection size (pipe)		Handwheel diameter Ø	H1	H2 (locking)
[DN]	[NPS]	[mm]		
15	1/2	45 (S)	217	224
20	3/4	45 (S)	224	230
25	1	45 (S)	228	234
32	1 1/4	45 (S)	296	303
40	1 1/2	45 ^{1.)} (S), 110 (M)	301	307
50	2	110 (M)	307	313
65	2 1/2	160 (L)	361	368
80	3	160 (L)	369	375
100	4	160 (L)	379	385

1.) At an operating pressure of less than 16 bar.

4.2. Body with flange connection

Note:

Dimensions in mm, unless otherwise stated

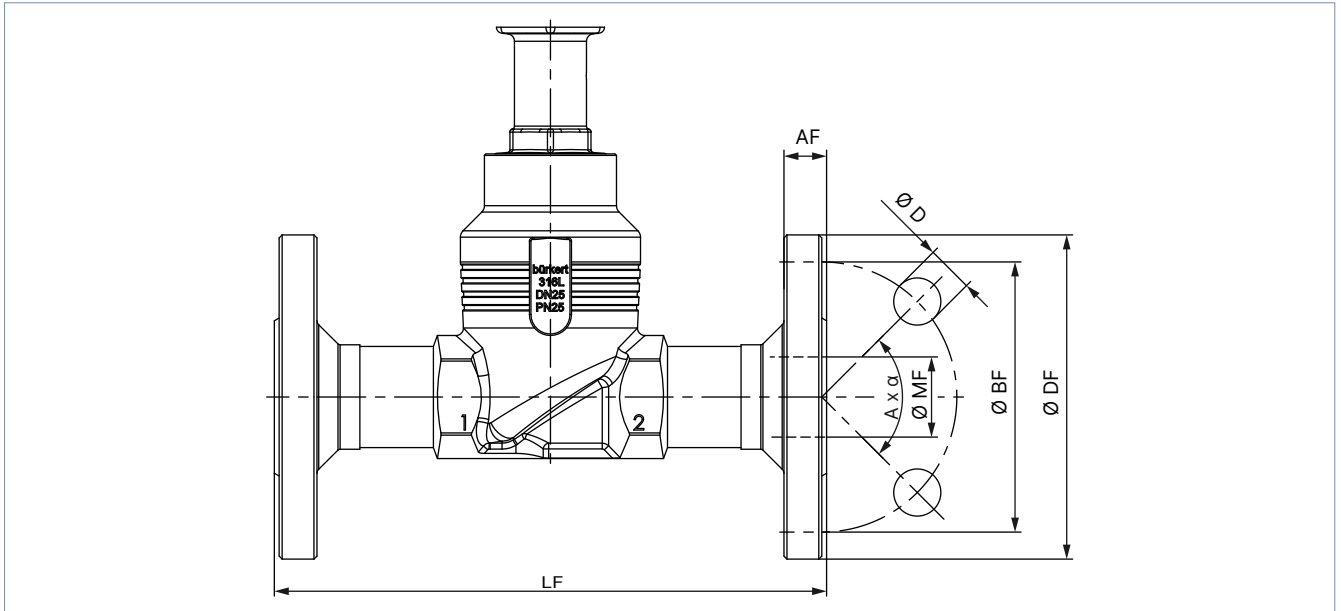

Nominal diameter (pipe)	DIN EN 1092 PN 25 FTF 1 acc. to DIN EN 558 - 1							JIS 10K FTF 10 acc. to DIN EN 558 - 2							
	DN	Ø DF	LF	Ø BF	AF	Ø D	A x α	Ø MF	Ø DF	LF	Ø BF	AF	Ø D	A x α	Ø MF
10	90	130	60	16	14	14	4 x 90°	13.6	-	-	-	-	-	-	-
15	95	130	65	16	14	14	4 x 90°	18.1	95	108	70	12	15	4 x 90°	18.1
20	105	150	75	18	14	14	4 x 90°	23.7	100	117	75	14	15	4 x 90°	23.7
25	115	160	85	18	14	14	4 x 90°	29.7	125	127	90	14	19	4 x 90°	29.7
32	140	180	100	18	18	18	4 x 90°	38.4	135	140	100	16	19	4 x 90°	38.4
40	150	200	110	18	18	18	4 x 90°	44.3	140	165	105	16	19	4 x 90°	44.3
50	165	230	125	20	18	18	4 x 90°	56.3	155	203	120	16	19	4 x 90°	56.3
65	185	290	145	22	18	18	8 x 45°	66.0	175	216	140	18	19	4 x 90°	71.5
80	200	310	160	24	18	18	8 x 45°	81.0	185	241	150	18	19	8 x 45°	84.3
100	235	350	190	24	22	22	8 x 45°	100.0	292	292	175	18	19	8 x 45°	109.1

Nominal diameter (pipe)	ANSI B 16.5 Class 150 FTF 37 acc. to DIN EN 558 - 2						
NPS	Ø DF	LF	Ø BF	AF	Ø D	A x α	Ø MF
½	89	184	60.5	11.2	15.7	4 x 90°	15.7
¾	99	184	69.9	12.7	15.7	4 x 90°	20.8
1	108	184	79.2	14.2	15.7	4 x 90°	26.7
1½	127	222	98.6	17.5	15.7	4 x 90°	40.9
2	152	254	120.7	19.1	19.1	4 x 90°	52.6
2½	178	276	139.7	22.3	19.1	4 x 90°	62.7
3	190	298	152.5	23.9	19.1	4 x 90°	78.0
4	229	352	190.5	23.9	19.1	8 x 45°	102.4

DTS 1000599141 EN Version: E Status: RL (released | freigegeben | valide) printed: 22.12.2025

4.3. Body with threaded connection

Note:

Dimensions in mm, unless otherwise stated

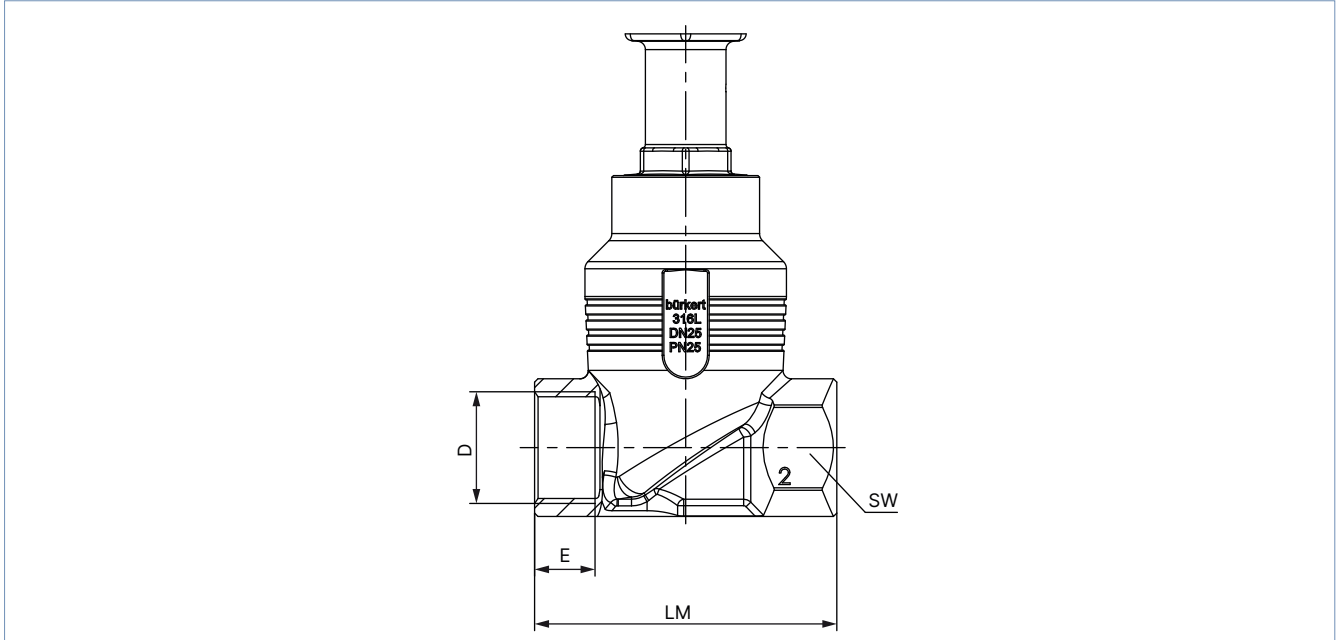

Nominal diameter (pipe)	G, Rc, NPT (EN ISO 228 - 1, ISO 7 - 1/DIN EN 10226 - 2, ASME B 1.20.1)				LM	SW
	D NPS	E [G]	[NPT]	[Rc]		
10	3/8	12	10.3	10.1	65	27
15	1/2	14	13.7	13.2	65	27
20	3/4	16	14	14.5	75	34
25	1	18	16.8	16.8	90	41
32	1 1/4	20	17.3	19.1	110	50
40	1 1/2	22	17.3	19.1	120	55
50	2	24	17.6	23.4	150	70
65	2 1/2	26	23.7	26.7	185	85
80	3	28	30.5	29.8	205	100
100	4	32	33	35.8	240	125

DTS 1000599141 EN Version: E Status: RL (released | freigegeben | valide) printed: 22.12.2025

4.4. Body with welded connection

Note:

Dimensions in mm, unless otherwise stated

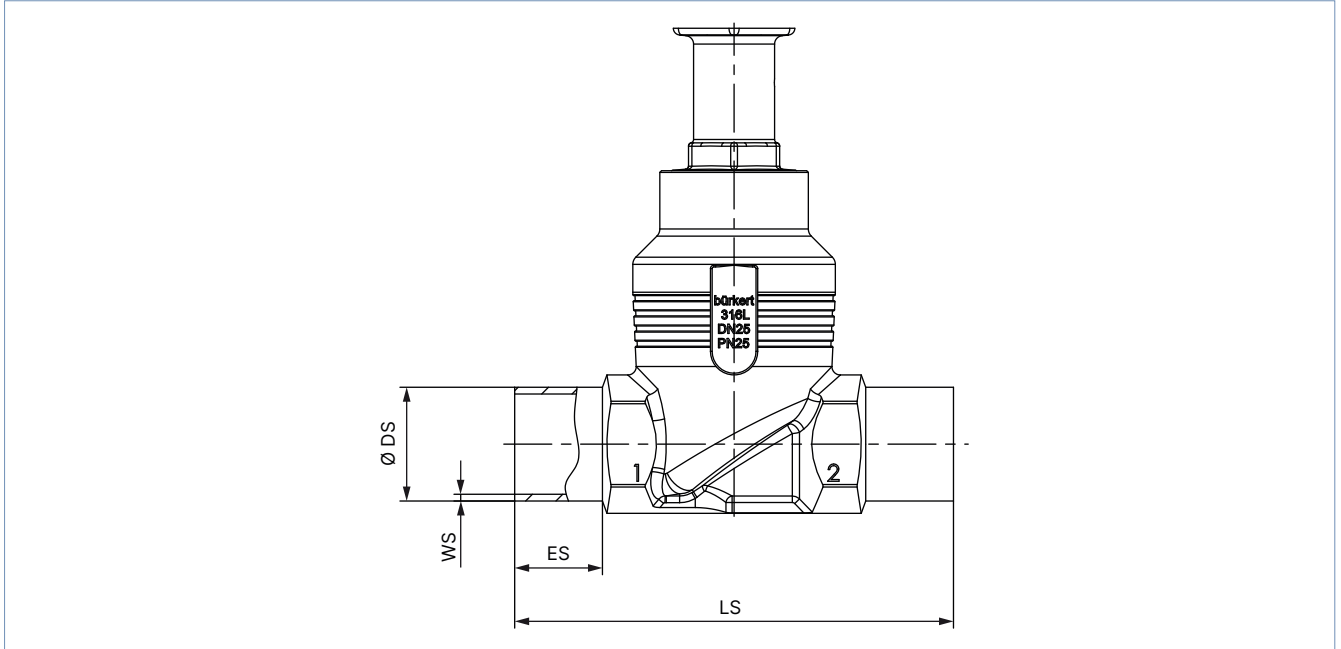

Nominal diameter (pipe) DN	ES	LS	EN ISO 1127 1/ISO 4200/ DIN 11866 series B		DIN 11850 - 2 /DIN 11866 series A/ DIN EN 10357 series A	
			Ø DS	WS	Ø DS	WS
10	20	90	17.2	1.6	13	1.5
15	20	90	21.3	1.6	19	1.5
20	20	100	26.9	1.6	23	1.5
25	26	130	33.7	2.0	29	1.5
32	26	140	42.4	2.0	35	1.5
40	26	150	48.3	2.0	41	1.5
50	26	175	60.3	2.0	53	1.5
65	26	210	76.1	2.3	70	2.0
80	26	230	88.9	2.3	85	2.0
100	26	260	114.3	2.6	104	2.0

Nominal diameter (pipe) NPS	ES	LS	ASME BPE/DIN 11866 series C	
			Ø DS	WS
1/2	20	90	12.7	1.65
3/4	20	90	19.05	1.65
1	20	100	25.4	1.65
1 1/2	26	140	38.1	1.65
2	26	150	50.8	1.65
2 1/2	26	175	63.5	1.65
3	26	210	76.2	1.65
4	26	260	101.6	2.11

DTS 1000599141 EN Version: E Status: RL (released | freigegeben | valide) printed: 22.12.2025

4.5. Body with clamp connection

Note:

Dimensions in mm, unless otherwise stated

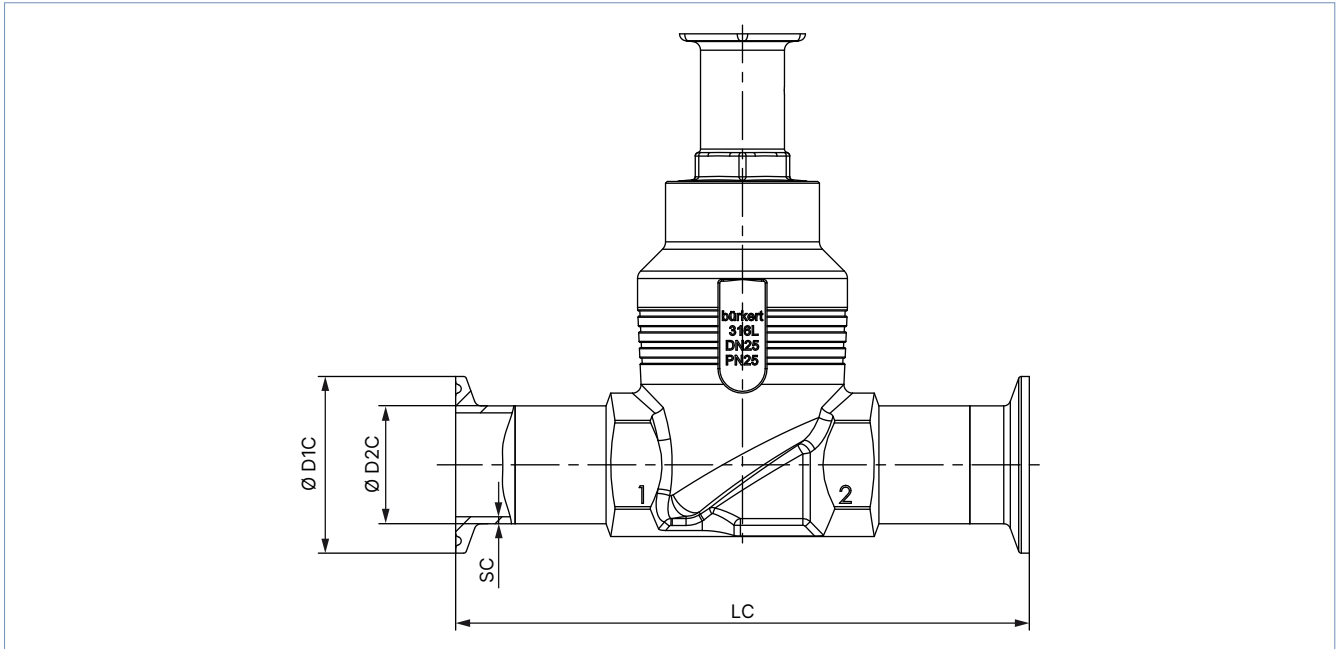

Nominal diameter (pipe)	Clamp: DIN 32676 series A				Clamp: DIN 32676 series B			
	Pipe: DIN 11850 - 2 DIN 11866 series A DIN EN 10357 series A				Pipe: EN ISO 1127 1 ISO 4200 DIN 11866 series B			
DN	LC	Ø D2 C	Ø D1 C	SC	LC	Ø D2 C	Ø D1 C	SC
15	126	19	34	1.5	146	21.3	50.5	1.6
20	136	23	34	1.5	136	26.9	50.5	1.6
25	173	29	50.5	1.5	164	33.7	50.5	2.0
40	193	41	50.5	1.5	193	48.3	64.0	2.0
50	218	53	64	1.5	218	60.3	77.5	2.0

Nominal diameter (pipe)	Clamp: ASME BPE DIN 32676 series C			
	Pipe: ASME BPE DIN 11866 series C			
NPS	LC	Ø D2 C	Ø D1 C	SC
1/2	122	12.7	25.0	1.65
3/4	126	19.05	25.0	1.65
1	126	25.4	50.5	1.65
1 1/2	172	38.1	50.5	1.65
2	182	50.8	64.0	1.65
2 1/2	231	63.5	77.5	1.65
3	265	76.2	91.0	1.65
4	315	101.6	119.0	2.11

DTS 1000599141 EN Version: E Status: RL (released | freigegeben | valide) printed: 22.12.2025

5. Performance specifications

5.1. Fluidic data

Overview of fluidic data for flow below seat (for liquids, steam and gases)

Note:

- K_v value [m^3/h]: measurement with water according to DIN EN 60534 - 2 - 4
- Seat leakage leakage rate A according to DIN EN 12266 - 1
- See "7.2. Bürkert product filter" on page 15

Nominal diameter (pipe)		Handwheel diameter \varnothing	Operating pressure max. CF A		K_v value
DN	NPS		Seat seal		
			PTFE	PEEK	
		[mm]	[bar(g)]	[bar(g)]	[m^3/h]
10	$\frac{3}{4}$	45 (S)	25	25	4.7
15	$\frac{1}{2}$	45 (S)	25	25	4.7
20	$\frac{3}{4}$	45 (S)	25	25	8.1
25	1	45 (S)	25	25	13.0
32	$1\frac{1}{4}$	45 (S)	25	25	20
40	$1\frac{1}{2}$	45 ¹⁾ (S). 110 (M)	25	25	31
50	2	110 (M)	25 (20 ²⁾)	23 (20 ²⁾)	45
65	$2\frac{1}{2}$	160 (L)	24 (15 ²⁾)	14	73
80	3	160 (L)	16	10	110
100	4	160 (L)	10	6	165

1.) At an operating pressure of less than 16 bar

2.) According to the Pressure Equipment Directive 97/23/EC for compressible fluids of Group 1 (hazardous gases and vapours according to Article 3 No. 1.3 letter a first dash)

5.2. Operating limits

Operating limits for medium temperature and operating pressure

In addition to the maximum operating pressures, the operating range of Bürkert process valves is limited by the nominal pressure according to the relevant standard.

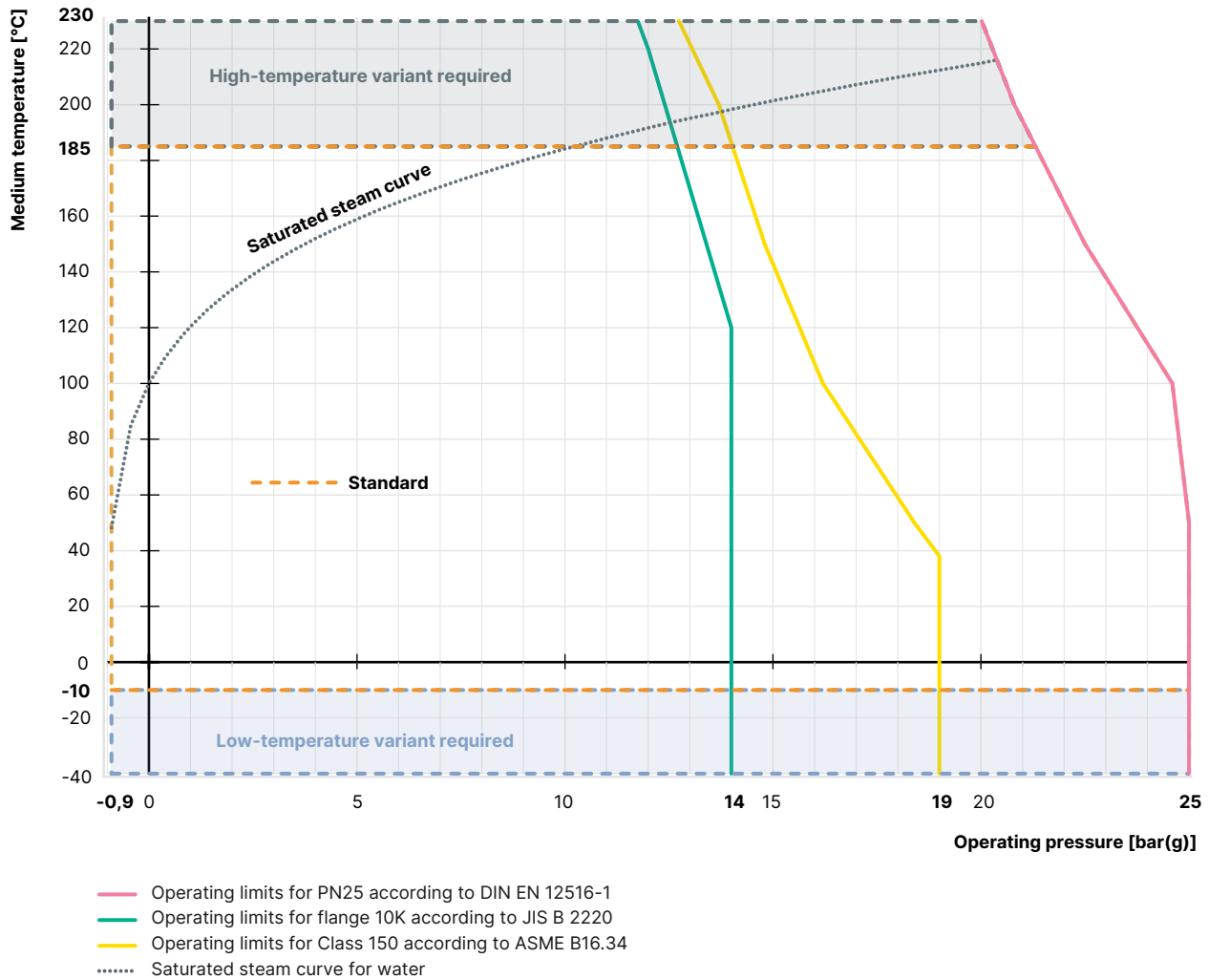

Operating limits for optional variants

High temperature variant

By adapting the packing gland this variant is suitable for applications with steam, neutral gases and other heat transfer mediums up to + 230 °C.

Water variant

For applications with water up to + 200 °C; a special configuration of the packing gland increases the lifetime significantly. It is recommended for all water applications.

Drinking water variant

The materials comply with the assessment principles (UBA) for materials in contact with drinking water up to + 85 °C.

Low temperature variant

Suitable for minimum medium temperatures down to - 40 °C

6. Product design and assembly

6.1. Product features

Note

Further information can be found in the **operating instructions Type 2921** ▶.

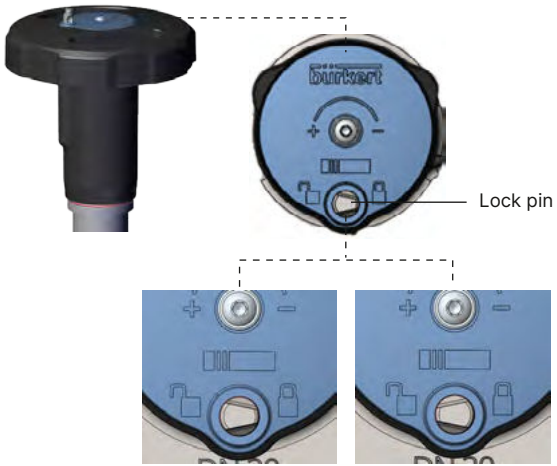
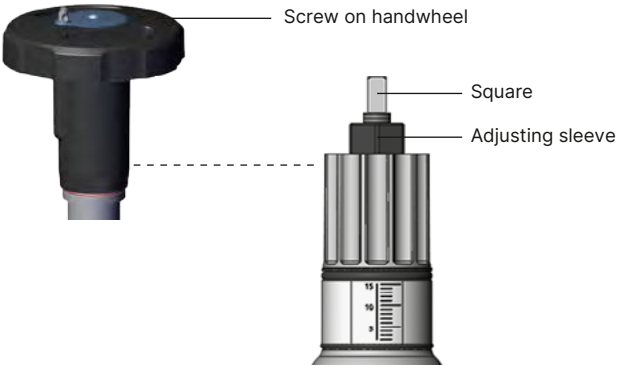
<p>Position indicator</p> <p>When the valve is opened (turn the handwheel anti-clockwise), the yellow position indicator becomes visible.</p>	 <p>Handwheel</p> <p>Position indicator</p>
<p>Interlock (optional)</p> <p>The valve can be secured against unintentional or unauthorized operation.</p> <p>For this purpose, a securing pin can be pressed down and turned.</p> <p>The locking pin has a hole (Ø 3.8) and can be secured with a padlock.</p>	 <p>Lock pin</p> <p>Closed position</p> <p>Open position</p>
<p>Stroke limitation (optional)</p> <p>Both the minimum and the maximum position of the valve can be adjusted via an adjustment sleeve. The handwheel can be removed for this purpose.</p>	 <p>Screw on handwheel</p> <p>Square</p> <p>Adjusting sleeve</p>

DTS 1000599141 EN Version: E Status: RL (released | freigegeben | valide) printed: 22.12.2025

7. Ordering information

7.1. Bürkert eShop



Bürkert eShop – Easy ordering and quick delivery

You want to find your desired Bürkert product or spare part quickly and order directly? Our online shop is available for you 24/7. Sign up and enjoy all the benefits.

[Order online now](#)

7.2. Bürkert product filter



Bürkert product filter – Get quickly to the right product

You want to select products comfortably based on your technical requirements? Use the Bürkert product filter and find suitable articles for your application quickly and easily.

[Try out our product filter](#)

7.3. Bürkert Product Enquiry Form

Note:

Please see our Product Enquiry Form for a full explanation of our specification key.

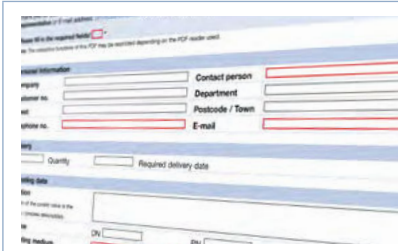

Bürkert Product Enquiry Form – Your enquiry quickly and compactly

Would you like to make a specific product enquiry based on your technical requirements? Use our Product Enquiry Form for this purpose. There you will find all the relevant information for your Bürkert contact. This will enable us to provide you with the best possible advice.

[Fill out the form now](#)

7.4. Ordering chart accessories

Standard accessories

Description	Article no.
4-fold nylon lock with 3 mm shackle	93719475

DTS 1000599141 EN Version: E Status: RL (released | freigegeben | valide) printed: 22.12.2025