



With pneumatic and electric actuators

ARI-STEVI® 470 / 471 - ANSI

**Pneumatic actuator
ARI-DP 32 - 35**

- Reversible pneumatic actuator
- Actuator with rolling diaphragm
- Air supply pressure max. 6 bar
- Stem protection by bellow
- Maintenance-free O-ring sealing
- Assembly of additional devices acc. to DIN IEC 60534-6

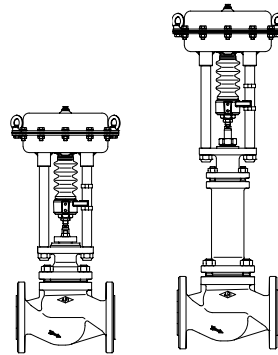

Page 4

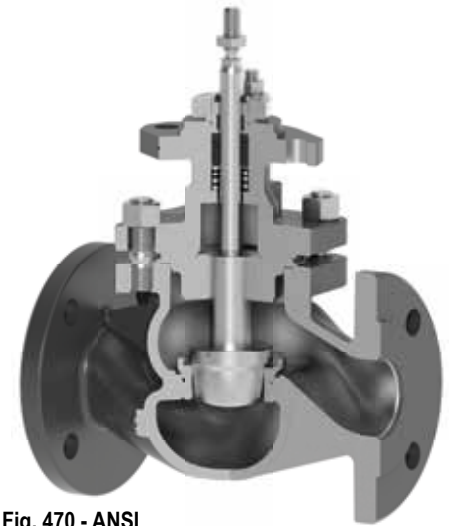
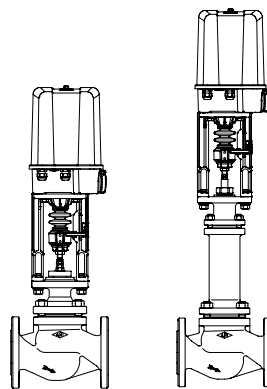

Fig. 470 - ANSI

ARI-STEVI® 470 / 471 - ANSI

**Electric actuator
ARI-PREMIO 2,2 - 25 kN
ARI-PREMIO-Plus 2G 2,2 - 25kN**

- Enclosure IP 65
- 2 torque switches
- Handwheel
- Additional devices available, e.g. potentiometer



Page 12

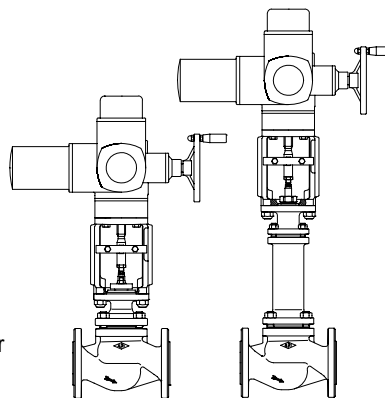

Fig. 470...4 - ANSI

ARI-STEVI® 470 / 471 - ANSI

**Electric actuator
AUMA SAR 07.2 - 14.6**

- Enclosure IP 67
- 2 torque switches
- 2 travel switches
- Handwheel
- Overheating protection for motor as standard
- Additional devices available, e.g. potentiometer
- Explosion proof version available



Page 14



Fig. 471 - ANSI

Figure	Version	Nominal pressure	Material	Nominal diameter	
32.470....90	with flanges	ANSI150	SA216WCB	DN 25-200 / NPS 1"-8"	Information / restriction of technical rules need to be observed! A production permission acc. to TRB 801 No. 45 is available. The engineer, designing a system or a plant, is responsible for the selection of the correct valve. Resistance and fitness must be verified, contact manufacturer for information (refer to Product overview and Resistance list).
32.471....90	with flanges	ANSI150	SA216WCB	DN 25-200 / NPS 1"-8"	
35.470....90	with flanges	ANSI300	SA216WCB	DN 25-200 / NPS 1"-8"	
35.470....4....90	with butt weld ends	ANSI300	SA216WCB	DN 25-150 / NPS 1"-6"	
35.471....90	with flanges	ANSI300 (restricted pressure)	SA216WCB	DN 25-200 / NPS 1"-8"	
35.471....4....90	with butt weld ends	ANSI300 (restricted pressure)	SA216WCB	DN 25-150 / NPS 1"-6"	
55.470....90	with flanges	ANSI300	SA351CF8M	DN 25-150 / NPS 1"-6"	
Other materials and versions on request.					

Stem sealing				
Fig. 470	standard		optional	
	DN25- 150 / NPS 1"-6"	DN200 / NPS 8"	DN25- 200 / NPS 1"-8"	DN25- 200 / NPS 1"-8"
	I. PTFE-V-ring unit -10°C to 220°C	II. PTFE-packing -10°C to 250°C	I. EPDM-sealing -10°C to 150°C (allowed for water and steam up to 180°C)	II. PTFE-packing -10°C to 250°C II. Pure graphite-packing -10°C to 425°C

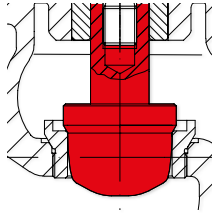
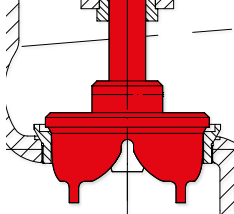
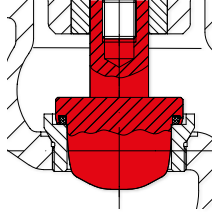
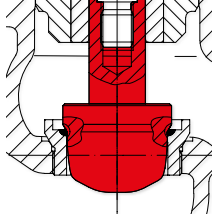
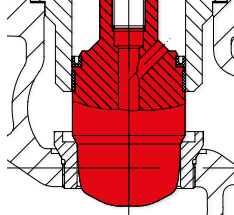
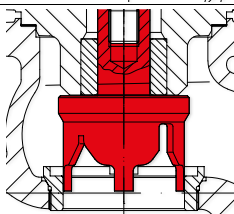

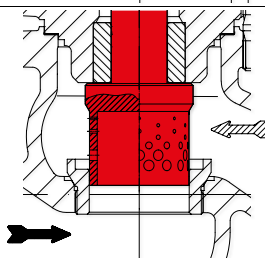

Fig. 471	standard		optional	
	DN25- 200 / NPS 1"-8"		DN25- 100 / NPS 1"-4"	DN150-200 / NPS 6"-8"
	III. Stainless steel-bellow with pure graphite-packing -29°C to 425°C		III. Stainless steel-bellow with V-ring unit -29°C to 220°C	III. Stainless steel-bellow with EPDM-sealing -29°C to 150°C (allowed for water and steam up to 180°C)

Pressure-temperature-ratings Intermediate values for max. permissible operational pressures can be determined by linear interpolation of the given temperature / pressure chart.

acc. to ANSI B16.5				-29°C to 38°C ¹⁾	50°C	100°C	150°C	200°C	250°C	300°C	350°C	400°C	425°C
Fig. 470 / 471	SA216WCB	ANSI150	(bar)	19,6	19,2	17,7	15,8	13,8	12,1	10,2	8,4	6,5	5,5
Fig. 470	SA216WCB	ANSI300	(bar)	51,1	50,1	46,6	45,1	43,8	41,9	39,8	37,6	34,7	28,8
Fig. 470	SA351CF8M	ANSI300	(bar)	49,6	48,1	42,2	38,5	35,7	33,4	31,6	30,9	29,4	29,1

acc. to manufacturers standard				-29°C to -10°C ¹⁾	-10°C to 120°C	150°C	200°C	250°C	300°C	350°C	400°C	425°C
Fig. 471-ANSI300	SA216WCB	ANSI300	(bar)	30	40	38,1	35	32	28	25,7	23,8	18,5
(restricted pressure)												

¹⁾ Valve with extended bonnet, studs and nuts made of B8M (at temperatures below -10°C)

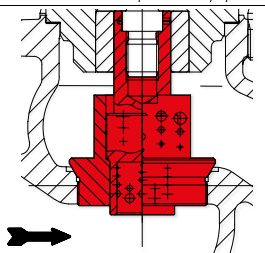
Plug design standard		Guiding	Rangeability
DN25-150 Parabolic plug, metal seat	<ul style="list-style-type: none"> - Leakage class IV acc. to ANSI / FCI 70-2 - from Kvs 0,1 - Flow characteristic: equal percentage (glp) (from Kvs 100 modified) linear (lin) (from Kvs 1) 	 Plug shaft	50 : 1
DN200 V-port plug metal seat	<ul style="list-style-type: none"> - Leakage class IV acc. to ANSI / FCI 70-2 - Flow characteristic: - equal percentage (glp) (from Kvs 100 modified) - linear (lin) 	 Plug shaft / Seat ring	30 : 1
Plug design optional		Guiding	Rangeability
Parabolic plug with PTFE-Soft seal (max. 200°C)	<ul style="list-style-type: none"> - Leakage class VI acc. to ANSI / FCI 70-2 - from Kvs 1,0 - Flow characteristic: - equal percentage (glp) (from Kvs 100 modified) - linear (lin) 	 Plug shaft	50 : 1
Parabolic plug with armoured sealing edge	<ul style="list-style-type: none"> - Leakage class IV acc. to ANSI / FCI 70-2 - from Kvs 1,0 - Flow characteristic: - equal percentage (glp) (from Kvs 100 modified) - linear (lin) 	 Plug shaft	50 : 1
Parabolic plug with Pressure balanced plug metal seat Piston seal: PTFE with stainless steel spring (max. 200°C)	<ul style="list-style-type: none"> - Leakage class IV acc. to ANSI / FCI 70-2 - from Kvs 6,3 - Flow characteristic: - equal percentage (glp) (from Kvs 100 modified) - linear (lin) 	 Plug shaft	50 : 1
V-port plug metal seat	<ul style="list-style-type: none"> - Leakage class IV acc. to ANSI / FCI 70-2 - from Kvs 63 - Flow characteristic: - equal percentage (glp) (from Kvs 100 modified) - linear (lin) 	 Plug shaft / Seat ring	30 : 1
Perforated plug metal seat optional: Pressure balanced perforated plug metal seat Piston seal: PTFE with stainless steel spring (max. 200°C)	<ul style="list-style-type: none"> - Leakage class IV acc. to ANSI / FCI 70-2 - from Kvs 1 - Flow characteristic: - equal percentage (glp) (from Kvs 100 modified) - linear (lin) <p>  Flow direction for gas and steam to reduce the sound level  Flow direction for liquids at critical operating conditions (cavitation / flashing) </p>	 Plug shaft / Seat ring	30 : 1
Perforated plug with perforated cage metal seat	<ul style="list-style-type: none"> - Leakage class IV acc. to ANSI / FCI 70-2 - Flow characteristic: equal percentage (glp) (from Kvs 100 modified) linear (lin) - multistage pressure reduction <p>  Flow direction for gas / steam and liquids to reduce the sound level at critical operating conditions </p>	 Plug shaft / Seat ring	30 : 1

Control valve in straightway form with pneumatic actuator ARI-DP

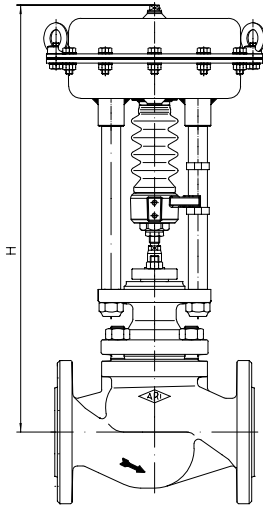

Fig. 470

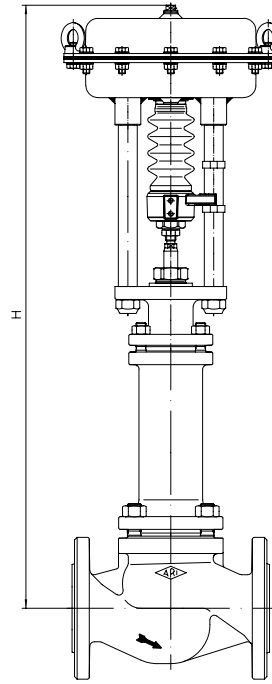

Fig. 471

Heights and weights

DN	25	40	50	80	100	150	200
NPS	1"	1 1/2"	2"	3"	4"	6"	8"

Fig. 470	Model	Dimension	Unit	DN							
				25	40	50	80	100	150	200	
Fig. 470	DP32	H	(mm)	473	504	504	522	524	584	--	
		ANSI150	(kg)	18	25	27	43	61	111	--	
		ANSI300	(kg)	20	28	30	50	75	136	--	
	DP33	H	(mm)	528	559	559	588	590	650	--	
		ANSI150	(kg)	24	31	33	49	67	117	--	
		ANSI300	(kg)	26	34	36	56	81	142	--	
	DP34	H	(mm)	--	694	694	723	725	785	844	
		ANSI150	(kg)	--	61	63	79	97	147	248	
		ANSI300	(kg)	--	64	66	86	111	172	264	
	DP34T	H	(mm)	--	--	--	--	--	1051	1094	
		ANSI150	(kg)	--	--	--	--	--	223	319	
		ANSI300	(kg)	--	--	--	--	--	248	335	
DP34Tri	H	(mm)	--	--	--	--	--	1273	1316		
	ANSI150	(kg)	--	--	--	--	--	257	353		
	ANSI300	(kg)	--	--	--	--	--	282	369		
DP35	H	(mm)	--	--	--	--	--	1154	1197		
	ANSI150	(kg)	--	--	--	--	--	422	518		
	ANSI300	(kg)	--	--	--	--	--	447	534		

Fig. 471	Model	Dimension	Unit	DN							
				25	40	50	80	100	150	200	
Fig. 471	DP32	H	(mm)	630	715	715	722	752	911	--	
		ANSI150	(kg)	22	26	28	45	65	114	--	
		ANSI300	(kg)	23	29	31	52	73	139	--	
	DP33	H	(mm)	685	770	770	788	818	977	--	
		ANSI150	(kg)	28	32	34	51	71	120	--	
		ANSI300	(kg)	29	35	37	58	79	145	--	
	DP34	H	(mm)	--	905	905	923	953	1112	1251	
		ANSI150	(kg)	--	62	64	81	101	150	233	
		ANSI300	(kg)	--	65	67	88	109	175	248	
	DP34T	H	(mm)	--	--	--	--	--	1573	1541	
		ANSI150	(kg)	--	--	--	--	--	256	304	
		ANSI300	(kg)	--	--	--	--	--	281	319	
DP34Tri	H	(mm)	--	--	--	--	--	1795	1763		
	ANSI150	(kg)	--	--	--	--	--	290	338		
	ANSI300	(kg)	--	--	--	--	--	315	353		
DP35	H	(mm)	--	--	--	--	--	1643	--		
	ANSI150	(kg)	--	--	--	--	--	455	--		
	ANSI300	(kg)	--	--	--	--	--	480	--		

Further dimensions refer to pages 18-23.

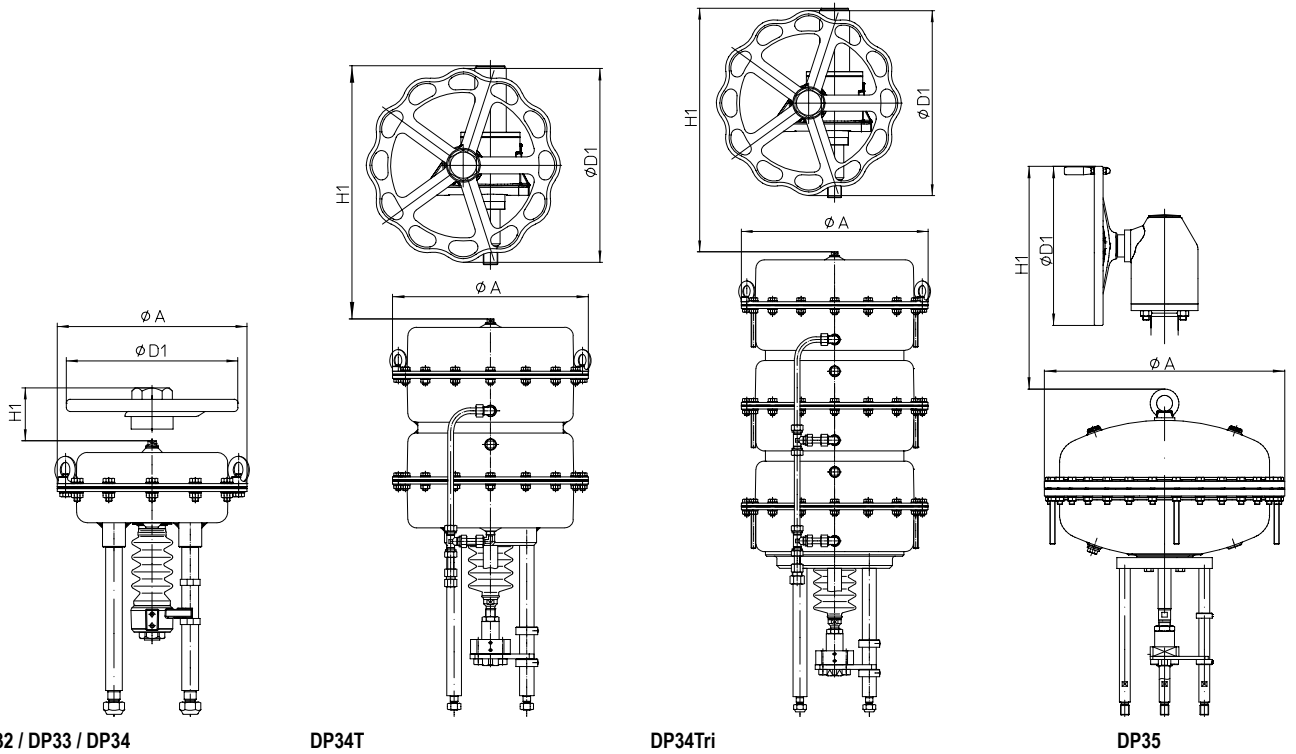

DP32 / DP33 / DP34

DP34T

DP34Tri

DP35

Actuator data		DP32	DP33	DP34	DP34T	DP34Tri	DP35
Ø A	(mm)	250	300	405		755	
Effective diaphragm area	(cm ²)	250	400	800	1600	2400	2800
Top mounted handwheel	Ø D1	(mm)	225	300	400		500
	H1	(mm)	270	284	442	635	731
	Weight	(kg)	5		17	41	

Further technical data of the actuator: refer to data sheet ARI-DP.



max. permissible closing pressures on flow-to-open P2 = 0.
Observe pressure-temperature-limits, refer to page 2.

DN			25						40			50			80			100			150			
NPS			1"						1 1/2"			2"			3"			4"			6"			
Parabolic plug	Kvs-value	(m³/h)	0,25 0,16 0,1	0,63 0,4	2,5 1,6 1	4	6,3	10	10	16	25	16	25	40	40	63	100	63	100	160	160			
	max. diff. pressure ¹⁾	(bar)	40						40	30	40	30	30	15	8	15	8	4	4					
V-port plug	Kvs-value	(m³/h)	--						--			--			63	100	63	100	160	160				
	max. diff. pressure ¹⁾	(bar)	--						--			--			30			30	25	25				
Perforated plug	Kvs-value	(m³/h)	--			2,5	4	6,3	6,3	10	16	10	16	25	25	40	63	40	63	100	100			
	max. diff. pressure ¹⁾	(bar)	--			40			40			40			40			40						
Seat-Ø		(mm)	3	5	12	18	22	25	25	32	40	32	40	50	50	65	80	65	80	100	100			
Travel		(mm)	20						20	30	20	30	30			30			30					
DP32 250 cm² Spring closes on air failure  (stem extending by spring)	0,4-1,2	1,4	I.	(bar)	51	51	51	25,8	16,8	12,6	11,9	6,7	3,8	6,7	3,8	2,1	2							
			II.	(bar)	51	51	49,9	21,4	13,8	10,3	8,8	4,8	2,6	4,8	2,6	1,3	1,1							
			III.	(bar)	9,7	9,4	8,4	7,5	7	6,5	6,5	3,6	1,8	3,6	1,8									
	0,8-2,4	2,7	I.	(bar)				51	40,8	31,4	30,6	18,3	11,3	18,3	11,3	6,9	6,8	3,7	2,2	3,7	2,2	1,2	1,2	
			II.	(bar)				51	51	37,8	29,1	27,5	16,4	10,1	16,4	10,1	6,1	5,9	3,2	1,9	3,2	1,9	1	1
			III.	(bar)	27,5	27,2	26,2	25,3	24,7	24,3	24,3	15,2	9,3	15,2	9,3	5,6	5,6	3	1,8	3	1,8			
	1,5-2,9	3,2	I.	(bar)					51	51	51	38,6		38,6										
			II.	(bar)					51	51	51	36,7		36,7										
			III.	(bar)	40	40	40	40	40	40	40	35,5		35,5										
	2,0-3,8	4,1	I.	(bar)								51		51										
			II.	(bar)								51		51										
			III.	(bar)								40		40										

DN			25						40			50			80			100			150		
NPS			1"						1 1/2"			2"			3"			4"			6"		
Parabolic plug	Kvs-value	(m³/h)	0,25 0,16 0,1	0,63 0,4	2,5 1,6 1	4	6,3	10	10	16	25	16	25	40	40	63	100	63	100	160	160		
	max. diff. pressure ¹⁾	(bar)	40						40	30	40	30	30	15	8	15	8	4	4				
V-port plug	Kvs-value	(m³/h)	--						--			--			63	100	63	100	160	160			
	max. diff. pressure ¹⁾	(bar)	--						--			--			30			30	25	25			
Perforated plug	Kvs-value	(m³/h)	--			2,5	4	6,3	6,3	10	16	10	16	25	25	40	63	40	63	100	100		
	max. diff. pressure ¹⁾	(bar)	--			40			40			40			40			40					
Seat-Ø		(mm)	3	5	12	18	22	25	25	32	40	32	40	50	50	65	80	65	80	100	100		
Travel		(mm)	20						20	30	20	30	30			30			30				
DP32 250 cm² Spring opens on air failure  (stem retracting by spring)	1,4	I.	(bar)	51	51	51	25,8	16,8	12,6	11,9	6,7	3,8	6,7	3,8	2,1	2							
		II.	(bar)	51	51	49,9	21,4	13,8	10,3	8,8	4,8	2,6	4,8	2,6	1,3	1,1							
		III.	(bar)	9,7	9,4	8,4	7,5	7	6,5	6,5	3,6	1,8	3,6	1,8									
	2	I.	(bar)				51	51	40,7	40	24,1	15,1	24,1	15,1	9,3	9,2	5,1	3,2	5,1	3,2	1,8	1,8	
		II.	(bar)				51	51	49,9	38,4	36,9	22,2	13,8	22,2	13,8	8,5	8,3	4,6	2,8	4,6	2,8	1,6	1,6
		III.	(bar)	36,3	36,1	35	34,2	33,6	33,2	33,2	21	13,1	21	13,1	8	8	4,4	2,7	4,4	2,7	1,5	1,4	
	3	I.	(bar)						51	51	51	33,8	51	33,8	21,4	21,3	12,4	8	12,4	8	4,9	4,9	
		II.	(bar)						51	51	51	32,6	51	32,6	20,6	20,4	11,8	7,6	11,8	7,6	4,7	4,7	
		III.	(bar)	40	40	40	40	40	40	40	31,8	40	31,8	20,1	20,1	11,6	7,5	11,6	7,5	4,6	4,4		
	4	I.	(bar)									51		51	33,5	33,4	19,6	12,7	19,6	12,7	8	8	
		II.	(bar)									51		51	32,7	32,5	19	12,4	19	12,4	7,8	7,8	
		III.	(bar)									40		40	32,2	32,2	18,9	12,3	18,9	12,3	7,7	7,5	
	5	I.	(bar)											45,6	45,5	26,8	17,5	26,8	17,5	11	11		
		II.	(bar)											44,8	44,6	26,2	17,2	26,2	17,2	10,8	10,8		
		III.	(bar)											40	40	26,1	17	26,1	17	10,8	10,6		
	6	I.	(bar)											51	51	34	22,3	34	22,3	14,1	14,1		
		II.	(bar)											51	51	33,4	21,9	33,4	21,9	13,9	13,9		
		III.	(bar)													33,3	21,8	33,3	21,8	13,8	13,6		

I. Fig. 470: PTFE-V-ring unit / EPDM-sealing
 II. Fig. 470: PTFE- / pure graphite-packing
 III. Fig. 471: Bellows seal

¹⁾ max. differential pressure drop

²⁾ Air supply pressure max. to actuator: 6 bar Restriction: a) 5 bar b) 4,5 bar c) 4 bar d) 3,5 bar e) 3 bar



max. permissible closing pressures on flow-to-open P2 = 0.
Observe pressure-temperature-limits, refer to page 2.

DN			25							40			50			80			100			150	
NPS			1"							1 1/2"			2"			3"			4"			6"	
Parabolic plug	Kvs-value	(m³/h)	0,25 0,16 0,1	0,63 0,4	2,5 1,6 1	4	6,3	10	10	16	25	16	25	40	40	63	100	63	100	160	160		
	max. diff. pressure ¹⁾	(bar)	40							40	30	40	30	30	15	8	15	8	4	4	4	4	
V-port plug	Kvs-value	(m³/h)	--							--			--			63			100	63	100	160	160
	max. diff. pressure ¹⁾	(bar)	--							--			--			30			30	25	25	25	25
Perforated plug	Kvs-value	(m³/h)	--			2,5	4	6,3	6,3	10	16	10	16	25	25	40	63	40	63	100	100	100	
	max. diff. pressure ¹⁾	(bar)	--			40			40			40			40			40			40	40	
Seat-Ø		(mm)	3	5	12	18	22	25	25	32	40	32	40	50	50	65	80	65	80	100	100		
Travel		(mm)	20							20	30	20	30	30			30			30			30
DP33 400 cm² Spring closes on air failure  (stem extending by spring)	Spring range (bar)	0,2-1,0	1,2	I. (bar)	51c)	51c)	43,7c)	18,6c)	11,9c)	8,8c)	8a)	4,3a)	2,3a)	4,3a)	2,3a)	1,1a)	1						
				II. (bar)	45,6c)	44,2c)	34,4c)	14,2c)	8,9c)	6,5c)	5a)	2,4a)	1,1a)	2,4a)	1,1a)								
				III. (bar)	6,1a)	5,8a)	4,8a)	3,9a)	3,3a)	2,9a)	2,9a)	1,2a)											
		0,4-1,2	1,4	I. (bar)			51c)	46,6c)	31c)	23,7c)	22,9a)	13,5a)	8,3a)	13,5a)	8,3a)	4,9a)	4,8	2,5	1,4	2,5	1,4		
				II. (bar)	51c)	51c)	51c)	42,3c)	28c)	21,4c)	19,9a)	11,6a)	7a)	11,6a)	7a)	4,1a)	3,9	2	1,1	2	1,1		
				III. (bar)	20,2a)	19,9a)	18,9a)	18a)	17,5a)	17a)	17a)	10,5a)	6,3a)	10,5a)	6,3a)	3,7a)	3,7	1,8	1	1,8	1		
	0,8-2,4	2,7	I. (bar)					51a)	51a)	51a)	51	32	20,2	32	20,2	12,6	12,5	7,1	4,5	7,1	4,5	2,7	2,7
			II. (bar)					51a)	51a)	51a)	49,7	30,1	19	30,1	19	11,8	11,6	6,6	4,1	6,6	4,1	2,5	2,5
	1,5-3,0	3,3	I. (bar)	40	40	40	40	40	40	40	28,9	18,2	28,9	18,2	11,3	11,3	6,4	4	6,4	4	2,4	2,4	2,2
			II. (bar)										41,1		41,1	26,1	26	15,1	9,8	15,1	9,8	6,1	6,1
			III. (bar)										39,9		39,9	25,3	25,1	14,6	9,5	14,6	9,5	5,9	5,9
	1,7-2,7	3,1	I. (bar)								51		51										
II. (bar)									51	51	51												
III. (bar)									40		40												
2,0-4,0	4,5	I. (bar)									51		51	35,7	35,6	20,9	13,6	20,9	13,6	8,5	8,5		
		II. (bar)									51		51	34,9	34,7	20,4	13,3	20,4	13,3	8,3	8,3		
		III. (bar)									40		40	34,4	34,4	20,2	13,1	20,2	13,1	8,2	8,1		

DN			25							40			50			80			100			150		
NPS			1"							1 1/2"			2"			3"			4"			6"		
Parabolic plug	Kvs-value	(m³/h)	0,25 0,16 0,1	0,63 0,4	2,5 1,6 1	4	6,3	10	10	16	25	16	25	40	40	63	100	63	100	160	160			
	max. diff. pressure ¹⁾	(bar)	40							40	30	40	30	30	15	8	15	8	4	4	4	4		
V-port plug	Kvs-value	(m³/h)	--							--			--			63			100	63	100	160	160	
	max. diff. pressure ¹⁾	(bar)	--							--			--			30			30	25	25	25	25	
Perforated plug	Kvs-value	(m³/h)	--			2,5	4	6,3	6,3	10	16	10	16	25	25	40	63	40	63	100	100	100		
	max. diff. pressure ¹⁾	(bar)	--			40			40			40			40			40			40	40		
Seat-Ø		(mm)	3	5	12	18	22	25	25	32	40	32	40	50	50	65	80	65	80	100	100			
Travel		(mm)	20							20	30	20	30	30			30			30			30	
DP33 400 cm² Spring opens on air failure  (stem retracting by spring)	Air supply pressure min. (bar) ²⁾	1,4	I. (bar)	51d)	51d)	51d)	46,6d)	31d)	23,7d)	22,9d)	13,5d)	8,3d)	13,5d)	8,3d)	4,9d)	4,8d)	2,5d)	1,4d)	2,5d)	1,4d)				
			II. (bar)	51d)	51d)	51d)	42,3d)	28d)	21,4d)	19,9d)	11,6d)	7d)	11,6d)	7d)	4,1d)	3,9d)	2d)	1,1d)	2d)	1,1d)	2d)	1,1d)		
			III. (bar)	20,2d)	19,9d)	18,9d)	18d)	17,5d)	17d)	17d)	10,5d)	6,3d)	10,5d)	6,3d)	3,7d)	3,7d)	1,8d)	1d)	1,8d)	1d)	1,8d)	1d)		
		2	2	I. (bar)				51d)	51d)	51d)	51d)	41,2d)	26,2d)	41,2d)	26,2d)	16,5d)	16,4d)	9,4d)	6d)	9,4d)	6d)	3,7d)	3,7d)	3,7d)
				II. (bar)				51d)	51d)	51d)	51d)	39,3d)	24,9d)	39,3d)	24,9d)	15,7d)	15,5d)	8,9d)	5,7d)	8,9d)	5,7d)	3,4d)	3,4d)	3,4d)
				III. (bar)	40d)	40d)	40d)	40d)	40d)	40d)	40d)	38,2d)	24,2d)	38,2d)	24,2d)	15,2d)	15,2d)	8,7d)	5,5d)	8,7d)	5,5d)	3,4d)	3,4d)	3,2d)
		3	3	I. (bar)								51d)	51d)	51d)	51d)	35,7d)	35,6d)	20,9d)	13,6d)	20,9d)	13,6d)	8,5d)	8,5d)	8,5d)
				II. (bar)								51d)	51d)	51d)	51d)	34,9d)	34,7d)	20,4d)	13,3d)	20,4d)	13,3d)	8,3d)	8,3d)	8,3d)
				III. (bar)								40d)	40d)	40d)	40d)	34,4d)	34,4d)	20,2d)	13,1d)	20,2d)	13,1d)	8,2d)	8,1d)	8,1d)
		4	4	I. (bar)												51a)	51	32,4	21,2	32,4	21,2	13,4	13,4	13,4
				II. (bar)												51a)	51	31,8	20,9	31,8	20,9	13,2	13,2	13,2
				III. (bar)												40a)	40	31,6	20,7	31,6	20,7	13,1	12,9	12,9
		5	5	I. (bar)													43,8	28,8	43,8	28,8	18,3	18,3	18,3	18,3
				II. (bar)													43,3	28,5	43,3	28,5	18,1	18,1	18,1	18,1
				III. (bar)													40	28,4	40	28,4	18	17,8	17,8	17,8
		6	6	I. (bar)													51	36,4	51	36,4	23,2	23,2	23,2	23,2
				II. (bar)													51	36,1	51	36,1	23	23	23	23
				III. (bar)														36		36	22,9	22,7	22,7	22,7

I. Fig. 470: PTFE-V-ring unit / EPDM-sealing
 II. Fig. 470: PTFE- / pure graphite-packing
 III. Fig. 471: Bellows seal

¹⁾ max. differential pressure drop

²⁾ Air supply pressure max. to actuator: 6 bar Restriction: a) 5 bar b) 4,5 bar c) 4 bar d) 3,5 bar e) 3 bar



max. permissible closing pressures on flow-to-open P2 = 0.
Observe pressure-temperature-limits, refer to page 2.

DN			40			50			80			100			150			200			
NPS			1 1/2"			2"			3"			4"			6"			8"			
Parabolic plug	Kvs-value	(m³/h)	10	16	25	16	25	40	40	63	100	63	100	160	160	250	400	--			
	max. diff. pressure ¹)	(bar)	40	40	30	40	30	30	30	15	8	15	8	4	4	2	2	--			
V-port plug	Kvs-value	(m³/h)	--			--			--			63	100	160	160	250	400	250	400	630	
	max. diff. pressure ¹)	(bar)	--			--			30			30	25	25	25	15	15	15	12	12	
Perforated plug	Kvs-value	(m³/h)	6,3	10	16	10	16	25	25	40	63	40	63	100	100	160	250	160	250	400	
	max. diff. pressure ¹)	(bar)	40			40			40			40			40			40	30	30	
Seat-Ø		(mm)	25	32	40	32	40	50	50	65	80	65	80	100	100	125	150	125	150	200	
Travel		(mm)	20		30	20	30		30			30			30	50		50	50	65	
DP34 800 cm² Spring closes on air failure  (stem extending by spring)	0,2-1,0	1,2	I. (bar)		8,3e)		8,3e)	5e)	4,9	2,6	1,5	2,6	1,5								
			II. (bar)		7,1e)		7,1e)	4,2e)	4	2	1,1	2	1,1								
			III. (bar)		6,4e)		6,4e)	3,7e)	3,7b)	1,9b)	1b)	1,9b)	1b)								
		1,4	I. (bar)		20,4d)		20,4d)	12,7d)	12,6	7,2	4,5	7,2	4,5	2,7	2,7	1,6	1	1,6			
			II. (bar)		19,1d)		19,1d)	11,9d)	11,7	6,6	4,2	6,6	4,2	2,5	2,5	1,4		1,2			
			III. (bar)		18,4d)		18,4d)	11,4b)	11,4d)	6,5b)	4,1b)	6,5b)	4,1b)	2,4b)	2,2	1,3		1,3 a)			
	2,7	I. (bar)		44,4b)		44,4b)	28,2b)	28,1	16,4	10,6	16,4	10,6	6,6	6,6	4,1	2,7	4,1	2,7			
		II. (bar)		43,2b)		43,2b)	27,4b)	27,2	15,9	10,3	15,9	10,3	6,4	6,4	4	2,6	3,8	2,5			
		III. (bar)		40b)		40b)	26,9b)	26,9	15,7	10,2	15,7	10,2	6,3	6,2	3,8	2,5	3,8	2,5			
	2,4	I. (bar)																		1,9	
		II. (bar)																		1,8	
		III. (bar)																		1,8	
	3,3	I. (bar)													8,5	5,8	8,5	5,8			
		II. (bar)													8,4	5,7	8,2	5,6			
		III. (bar)													8,2	5,6	8,2	5,6			
	3,3	I. (bar)			51a)		51a)	51a)	51	46,4	30,5	46,4	30,5	19,4	19,4						
		II. (bar)			51a)		51a)	51a)	51	45,9	30,2	45,9	30,2	19,2	19,2						
		III. (bar)			40a)		40a)	40	40	40	30,1	40	30,1	19,1	18,9						
	4,5	I. (bar)														11,7	8	11,7	8	4,4	
		II. (bar)														11,5	7,9	11,3	7,8	4,3	
		III. (bar)														11,4	7,8	11,4	7,8	4,3	
	4	I. (bar)							51	35,1	51	35,1	22,4	22,4							
		II. (bar)							51	34,8	51	34,8	22,2	22,2							
		III. (bar)								34,7		34,7	22,1	21,9							

DN			40			50			80			100			150			200		
NPS			1 1/2"			2"			3"			4"			6"			8"		
Parabolic plug	Kvs-value	(m³/h)	10	16	25	16	25	40	40	63	100	63	100	160	160	250	400			
	max. diff. pressure ¹)	(bar)	40	40	30	40	30	30	30	15	8	15	8	4	4	2	2			
V-port plug	Kvs-value	(m³/h)							63			100	160	250	400	250	400	630		
	max. diff. pressure ¹)	(bar)							30			30	25	25	15	15	15	12		
Perforated plug	Kvs-value	(m³/h)	6,3	10	16	10	16	25	25	40	63	40	63	100	100	160	250	160	250	400
	max. diff. pressure ¹)	(bar)	40			40			40			40			40			40	30	30
Seat-Ø		(mm)	25	32	40	32	40	50	50	65	80	65	80	100	100	125	150	125	150	200
Travel		(mm)	20		30	20	30		30			30			30	50		50	50	65
DP34 800 cm² Spring opens on air failure  (stem retracting by spring)	1,4	I. (bar)		20,4e)		20,4e)	12,7e)	12,6	7,2	4,5	7,2	4,5	2,7	2,7	1,6	1	1,6	1		
			II. (bar)		19,1e)		19,1e)	11,9e)	11,7	6,6	4,2	6,6	4,2	2,5	2,5	1,4		1,2		
			III. (bar)		18,4e)		18,4e)	11,4b)	11,4e)	6,5b)	4,1b)	6,5b)	4,1b)	2,4b)	2,2	1,3		1,3a)		
		2	I. (bar)		51e)		51e)	36e)	35,9	21	13,7	21	13,7	8,6	8,6	5,4	3,6	5,3	3,6	1,9
			II. (bar)		51e)		51e)	35,2e)	35	20,5	13,4	20,5	13,4	8,4	8,4	5,2	3,5	5	3,4	1,8
			III. (bar)		40e)		40e)	34,7e)	34,7b)	20,3b)	13,2b)	20,3b)	13,2b)	8,3b)	8,1	5,1	3,4	5,1a)	3,4a)	1,8a)
	3	I. (bar)					51e)	51	44,1	29	44,1	29	18,4	18,4	11,7	8	11,7	8	4,4	
		II. (bar)					51e)	51	43,6	28,7	43,6	28,7	18,2	18,2	11,5	7,9	11,3	7,8	4,3	
		III. (bar)					40e)	40b)	40b)	28,5b)	40b)	28,5b)	18,1b)	18	11,4	7,8	11,4a)	7,8a)	4,3a)	
	4	I. (bar)						51	44,3	28,3	51	44,3	28,3	28,3	18	12,4	18	12,4	6,9	
		II. (bar)						51	44	28,1	51	44	28,1	28,1	17,9	12,3	17,7	12,2	6,7	
		III. (bar)							40b)	40b)	28b)	40b)	28b)	27,8	17,7	12,2	17,7a)	12,2a)	6,8a)	
	5	I. (bar)						51		38,1	51	38,1	38,1	24,3	16,8	24,3	16,8	24,3	9,3	
		II. (bar)						51		37,9	51	37,9	37,9	24,2	16,7	24	16,6	24	9,2	
		III. (bar)												37,6	24	16,6	24a)	16,6a)	9,2a)	
	6	I. (bar)												48	48	30,6	21,2	30,6	21,2	11,8
		II. (bar)												47,7	47,7	30,5	21,1	30,3	21	11,7
		III. (bar)												40	30,3	21				

- I. Fig. 470: PTFE-V-ring unit / EPDM-sealing
- II. Fig. 470: PTFE- / pure graphite-packing
- III. Fig. 471: Bellows seal

¹) max. differential pressure drop

²) Air supply pressure max. to actuator: 6 bar Restriction: a) 5 bar b) 4,5 bar c) 4 bar d) 3,5 bar e) 3 bar

max. permissible closing pressures on flow-to-open P2 = 0.
Observe pressure-temperature-limits, refer to page 2.

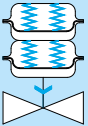
DN				150			200			
NPS				6"			8"			
Parabolic plug	Kvs-value	(m³/h)	160	250	400	--				
	max. diff. pressure ¹⁾	(bar)	4	2		--				
V-port plug	Kvs-value	(m³/h)	160	250	400	250	400	630		
	max. diff. pressure ¹⁾	(bar)	25	15		15				
Perforated plug	Kvs-value	(m³/h)	100	160	250	160	250	400		
	max. diff. pressure ¹⁾	(bar)	40			40				
Seat-Ø			(mm)	100	125	150	125	150	200	
Travel			(mm)	30	50		50			
DP34T 1600 cm² Spring closes on air failure  (stem extending by spring)	Spring range (bar)	0,2-1,0	1,5	I. (bar)	2,7	1,6	1	1,6		
				II. (bar)	2,2	1,2		1,2		
				III. (bar)	2 a)	1,1 a)		1,3 e)		
		0,4-1,2	1,7	I. (bar)	6,6	4,1	2,7	4,1	2,7	1,4
				II. (bar)	6,1	3,8	2,5	3,8	2,5	1,3
				III. (bar)	6 a)	3,7 a)	2,4 a)	3,8 d)	2,5 d)	1,3 d)
	0,8-2,4	2,9	I. (bar)	14,5	9,1	6,2	9,1	6,2		
			II. (bar)	14	8,8	6	8,8	6		
			III. (bar)	13,8	8,7	6	8,8 b)	6 b)		
	1,0-2,0	2,5	I. (bar)						4,4	
			II. (bar)						4,3	
			III. (bar)						4,3 c)	
	1,5-3,0	3,5	I. (bar)		18	12,4	18	12,4		
			II. (bar)		17,7	12,2	17,7	12,2		
			III. (bar)		17,6	12,1	17,7 a)	12,2 a)		
	2,1-3,0	3,5	I. (bar)	40,1						
			II. (bar)	39,6						
			III. (bar)	39,4						
	2,0-4,0	4,5	I. (bar)		24,3	16,8	24,3	16,8	9,3	
			II. (bar)		24	16,6	24	16,6	9,2	
			III. (bar)		23,9	16,5	24	16,6	9,2	
	2,4-3,6	4,1	I. (bar)	46						
			II. (bar)	45,5						
			III. (bar)	40						

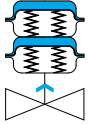
DN				150			200			
NPS				6"			8"			
Parabolic plug	Kvs-value	(m³/h)	160	250	400	--				
	max. diff. pressure ¹⁾	(bar)	4	2		--				
V-port plug	Kvs-value	(m³/h)	160	250	400	250	400	630		
	max. diff. pressure ¹⁾	(bar)	25	15		15				
Perforated plug	Kvs-value	(m³/h)	100	160	250	160	250	400		
	max. diff. pressure ¹⁾	(bar)	40			40				
Seat-Ø			(mm)	100	125	150	125	150	200	
Travel			(mm)	30	50		50			
DP34T 1600 cm² Spring opens on air failure  (stem retracting by spring)	Air supply pressure min. (bar) ²⁾	1,5		I. (bar)	8,6	5,3	3,6	5,3	3,6	1,9
				II. (bar)	8,1	5	3,4	5	3,4	1,8
				III. (bar)	7,9 a)	4,9 a)	3,3 a)	5,1 e)	3,4 e)	1,8 e)
		2		I. (bar)	18,4	11,7	8	11,7	8	4,4
				II. (bar)	17,9	11,3	7,8	11,3	7,8	4,3
				III. (bar)	17,8 a)	11,2 a)	7,7 a)	11,4 e)	7,8 e)	4,3 e)
	3		I. (bar)	38,1	24,3	16,8	24,3	16,8	9,3	
			II. (bar)	37,6	24	16,6	24	16,6	9,2	
			III. (bar)	37,4 a)	23,9 a)	16,5 a)	24 e)	16,6 e)	9,2 e)	
	4		I. (bar)	51	36,9	25,6	36,9	25,6	14,3	
			II. (bar)	51	36,6	25,4	36,6	25,4	14,2	
			III. (bar)	40 a)	36,5 a)	25,3 a)				
	5		I. (bar)		49,6	34,4	49,6	34,4	19,3	
			II. (bar)		49,2	34,2	49,2	34,2	19,1	
			III. (bar)		40 a)	34,1 a)				
	6		I. (bar)		51	43,2	51	43,2	24,2	
			II. (bar)		51	42,9	51	42,9	24,1	
			III. (bar)							

- I. Fig. 470: EPDM-sealing
- II. Fig. 470: PTFE- / pure graphite-packing
- III. Fig. 471: Bellows seal

¹⁾ max. differential pressure drop

²⁾ Air supply pressure max. to actuator: 6 bar Restriction: a) 5 bar b) 4,5 bar c) 4 bar d) 3,5 bar e) 3 bar f) 2,5 bar

max. permissible closing pressures on flow-to-open P2 = 0.
Observe pressure-temperature-limits, refer to page 2.

DN				150			200			
NPS				6"			8"			
Parabolic plug	Kvs-value	(m³/h)		160	250	400	--			
	max. diff. pressure ¹⁾	(bar)		4	2		--			
V-port plug	Kvs-value	(m³/h)		160	250	400	250	400	630	
	max. diff. pressure ¹⁾	(bar)		25	15		15		12	
Perforated plug	Kvs-value	(m³/h)		100	160	250	160	250	400	
	max. diff. pressure ¹⁾	(bar)		40			40		30	
Seat-Ø			(mm)	100	125	150	125	150	200	
Travel			(mm)	30	50		50		65	
<p style="text-align: center;">DP34Tri 2400 cm² Spring closes on air failure</p> <p style="text-align: center;">(stem extending by spring)</p>	0,2-1,0	1,5	I.	(bar)	4,6 a)	2,8 a)	1,9 a)	2,8 a)	1,9 a)	
			II.	(bar)	4,1 a)	2,5 a)	1,6 a)	2,5 a)	1,6 a)	
			III.	(bar)	4 d)	2,4 d)	1,6 d)	2,5 f)	1,6 f)	
			I.	(bar)	10,6 a)	6,6 a)	4,5 a)	6,6 a)	4,5 a)	2,4 a)
			II.	(bar)	10,1 a)	6,3 a)	4,3 a)	6,3 a)	4,3 a)	2,3 a)
			III.	(bar)	9,9 c)	6,2 c)	4,2 c)	6,3 f)	4,3 f)	2,3 f)
	0,4-1,2	1,7	I.	(bar)	22,4 a)	14,2 a)	9,8 a)	14,2 a)	9,8 a)	5,4 a)
			II.	(bar)	21,9 a)	13,9 a)	9,5 a)	13,9 a)	9,5 a)	5,3 a)
			III.	(bar)	21,7 a)	13,8 a)	9,5 a)	13,9 d)	9,6 d)	5,3 d)
	0,8-2,4	2,9	I.	(bar)						6,9 a)
			II.	(bar)						6,7 a)
			III.	(bar)						6,8 d)
	1,0-2,0	2,5	I.	(bar)		27,5 a)	19 a)	27,5 a)	19 a)	10,6 a)
			II.	(bar)		27,1 a)	18,8 a)	27,1 a)	18,8 a)	10,5 a)
			III.	(bar)		27 a)	18,7 a)	27,2 b)	18,8 b)	10,5 b)
	1,5-3,0	3,5	I.	(bar)	51 a)					
			II.	(bar)	51 a)					
			III.	(bar)	40 a)					
	2,1-3,0	3,5	I.	(bar)		36,9 a)	25,6 a)	36,9 a)	25,6 a)	14,3 a)
			II.	(bar)		36,6 a)	25,4 a)	36,6 a)	25,4 a)	14,2 a)
			III.	(bar)		36,5 a)	25,3 a)			
	2,0-4,0	4,5	I.	(bar)						
			II.	(bar)						
			III.	(bar)						

- I. Fig. 470: EPDM-sealing
- II. Fig. 470: PTFE- / pure graphite-packing
- III. Fig. 471: Bellows seal

¹⁾ max. differential pressure drop

²⁾ Air supply pressure max. to actuator: 5 bar Restriction: a) 5 bar b) 4,5 bar c) 4 bar d) 3,5 bar e) 3 bar

max. permissible closing pressures on flow-to-open P2 = 0.
Observe pressure-temperature-limits, refer to page 2.

DN						150		200		
NPS						6"		8"		
Parabolic plug	Kvs-value		(m³/h)	250	400	--				
	max. diff. pressure ¹⁾		(bar)	2		--				
V-port plug	Kvs-value		(m³/h)	250	400	250	400	630		
	max. diff. pressure ¹⁾		(bar)	15		15				
Perforated plug	Kvs-value		(m³/h)	160	250	160	250	400		
	max. diff. pressure ¹⁾		(bar)	40		40				
Seat-Ø			(mm)	125	150	125	150	200		
Travel			(mm)	50		50		65		
<p>DP35 2800 cm² Spring closes on air failure (stem extending by spring)</p>	Spring range (bar)	2,45-3,28	3,8	I./II.	(bar)	51	37,4	51	37,4	
				III.	(bar)	40 a)	37,3 a)			
		2,97-3,8	4,3	I./II.	(bar)		45,5		45,5	
		2,72-3,8	4,3	I./II.	(bar)				23,4	

DN						150		200		
NPS						6"		8"		
Parabolic plug	Kvs-value		(m³/h)	250	400	--				
	max. diff. pressure ¹⁾		(bar)	2		--				
V-port plug	Kvs-value		(m³/h)	250	400	250	400	630		
	max. diff. pressure ¹⁾		(bar)	15		15				
Perforated plug	Kvs-value		(m³/h)	160	250	160	250	400		
	max. diff. pressure ¹⁾		(bar)	40		40				
Seat-Ø			(mm)	125	150	125	150	200		
Travel			(mm)	50		50		65		
<p>DP35 2800 cm² Spring opens on air failure (stem retracting by spring)</p>	Air supply pressure min. (bar ²⁾)	1,5		I./II.	(bar)	12,7 b)	8,7 b)	12,7 b)	8,7 b)	4,1 b)
				III.	(bar)	12,6 e)	8,6 e)			
		2		I./II.	(bar)	23,9 b)	16,6 b)	23,9 b)	16,6 b)	8,5 b)
				III.	(bar)	23,8 e)	16,5 e)			
		3		I./II.	(bar)	46,5 b)	32,2 b)	46,5 b)	32,2 b)	17,3 b)
				III.	(bar)	40 e)	32,2 e)			
		4		I./II.	(bar)	51 b)	47,9)	51 b)	47,9 b)	26,2 b)
		4,5		I./II.	(bar)		51 b)		51 b)	30,6 b)

I. Fig. 470: EPDM-sealing
II. Fig. 470: PTFE- / pure graphite-packing
III. Fig. 471: Bellows seal

¹⁾ max. differential pressure drop

²⁾ Air supply pressure max. to actuator: 6 bar Restriction: a) 5 bar b) 4,5 bar c) 4 bar d) 3,5 bar e) 3 bar

Control valve in straightway form with electric actuator ARI-PREMIO / PREMIO-Plus 2G

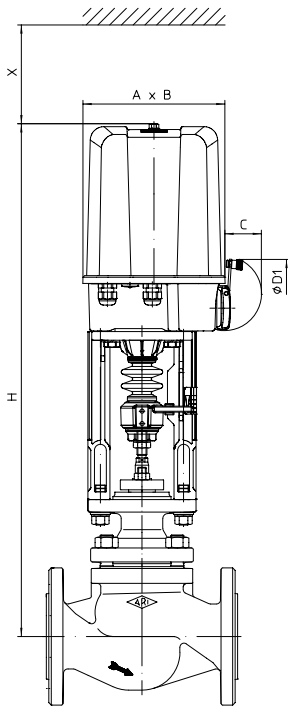

Fig. 470...90

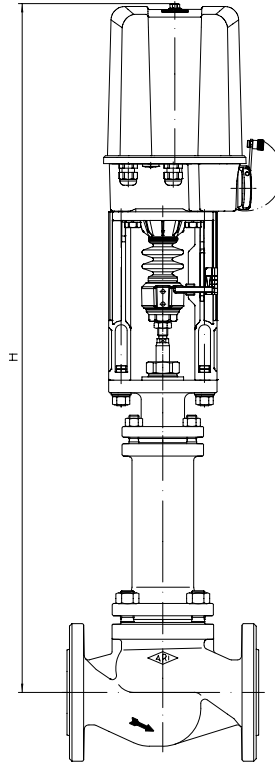

Fig. 471...90

Actuator data		2,2 - 5 kN	12 - 25 kN
A	(mm)	171	210
B	(mm)	156	184
C	(mm)	50	90
Ø D1	(mm)	90	130
X	(mm)	150	200

Further technical data of the actuator: refer to data sheet ARI-PREMIO/PREMIO-Plus 2G

Heights and weights

DN		25	40	50	80	100	150	200	
NPS		1"	1 1/2"	2"	3"	4"	6"	8"	
Fig. 470	2,2 kN	H (mm)	582	613	613	642	644	724	--
		ANSI150 (kg)	15	21	23	39	58	108	--
		ANSI300 (kg)	16	24	26	46	72	133	--
	5 kN	H (mm)	582	613	613	642	644	724	842
		ANSI150 (kg)	16	22	24	40	59	109	183
		ANSI300 (kg)	17	25	27	47	73	134	200
	12 kN	H (mm)	--	787	787	816	818	878	996
		ANSI150 (kg)	--	26	28	44	63	113	186
	15 kN	ANSI300 (kg)	--	29	31	51	77	138	203
		25 kN	H (mm)	--	--	--	816	818	878
	ANSI150 (kg)		--	--	--	45	64	114	187
	ANSI300 (kg)		--	--	--	52	78	139	204
Fig. 471	2,2 kN	H (mm)	739	824	824	842	872	1045	--
		ANSI150 (kg)	18	23	25	41	62	111	--
		ANSI300 (kg)	19	26	28	48	70	136	--
	5 kN	H (mm)	739	824	824	842	872	1045	1264
		ANSI150 (kg)	19	24	26	42	63	112	209
		ANSI300 (kg)	20	27	29	49	71	137	226
	12 kN	H (mm)	--	998	998	1016	1046	1205	1433
		ANSI150 (kg)	--	28	30	46	67	116	212
	15 kN	ANSI300 (kg)	--	31	33	53	75	141	229
		25 kN	H (mm)	--	--	--	1016	1046	1205
	ANSI150 (kg)		--	--	--	47	68	117	213
	ANSI300 (kg)		--	--	--	54	76	142	230

Further dimensions refer to pages 18-23.



max. permissible closing pressures on flow-to-open P2 = 0.
Observe pressure-temperature-limits, refer to page 2.

DN			25						40			50			80			100			150			200		
NPS			1"						1 1/2"			2"			3"			4"			6"			8"		
Parabolic plug	Kvs-value	(m³/h)	0,25 0,16 0,1	0,63 0,4	2,5 1,6 1	4	6,3	10	10	16	25	16	25	40	40	63	100	63	100	160	160	250	400	--		
	max. diff. pressure ¹⁾	(bar)	40						40	30	40	30	30	15	8	15	8	4	4	2	--					
V-port plug	Kvs-value	(m³/h)	--						--			--			63	100	63	100	160	160	250	400	250	400	630	
	max. diff. pressure ¹⁾	(bar)	--						--			--			30			30	25	25	15	15	12			
Perforated plug	Kvs-value	(m³/h)	--			2,5 1,6 1	4	6,3	6,3	10	16	10	16	25	25	40	63	40	63	100	100	160	250	160	250	400
	max. diff. pressure ¹⁾	(bar)	--			40			40			40			40			40			40	30				
Seat-Ø		(mm)	3	5	12	18	22	25	25	32	40	32	40	50	50	65	80	65	80	100	100	125	150	125	150	200
Travel		(mm)	20						20	30	20	30	30			30			30	50	50	50	65			
2,2 kN	Closing pressure	I. (bar)	51	51	51	51	46,7	35,9	35,2	21,1	13,2	21,1	13,2	8,1	8	4,4	2,7	4,4	2,7	1,5	1,5					
		II. (bar)	51	51	51	51	43,7	33,7	32,1	19,2	11,9	19,2	11,9	7,3	7,1	3,9	2,3	3,9	2,3	1,3	1,3					
		III. (bar)	31,8	31,5	30,5	29,6	29,1	28,6	28,6	18	11,2	18	11,2	6,8	6,8	3,7	2,2	3,7	2,2	1,2	1					
	Operating time (50 Hz)	(s)	53						53	79	53	79	79			79			79							
	Operating speed ²⁾	(mm/s)	0,38																							
5 kN	Closing pressure	I. (bar)					51	51	51	51	34,6	51	34,6	21,9	21,8	12,6	8,2	12,6	8,2	5	5	3,1	2	3,1	2	1
		II. (bar)					51	51	51	51	33,4	51	33,4	21,1	20,9	12,1	7,8	12,1	7,8	4,8	4,8	2,9	1,9	2,7	1,8	
		III. (bar)	40	40	40	40	40	40	40	40	32,6	40	32,6	20,6	20,6	11,9	7,7	11,9	7,7	4,7	4,5	2,8	1,8	2,8	1,8	
	Operating time	(s)	53						53	79	53	79	79			79			79	132	132					
	Operating speed	(mm/s)	0,38																							
12 kN	Closing pressure	I. (bar)									51		51	51	51	33,2	21,8	33,2	21,8	13,8	13,8	8,7	5,9	8,7	5,9	3,2
		II. (bar)									51		51	51	51	32,7	21,5	32,7	21,5	13,6	13,6	8,6	5,8	8,4	5,7	3,1
		III. (bar)									40		40	40	40	32,5	21,3	32,5	21,3	13,5	13,3	8,4	5,7	8,4	5,7	3,1
	Operating time	(s)										79		79		79		79		79	132	132	171			
	Operating speed	(mm/s)	0,38																							
15 kN	Closing pressure	I. (bar)														42,1	27,7	42,1	27,7	17,6	17,6	11,1	7,6	11,1	7,6	4,2
		II. (bar)														41,5	27,3	41,5	27,3	17,3	17,3	11	7,5	10,8	7,4	4
		III. (bar)														40	27,2	40	27,2	17,3	17,1	10,8	7,4	10,8	7,4	4,1
	Operating time	(s)													79		79		79	132	132	171				
	Operating speed	(mm/s)	0,38																							
25 kN	Closing pressure	I. (bar)														51	47,2	51	47,2	30,1	30,1	19,1	13,2	19,1	13,2	7,3
		II. (bar)														51	46,8	51	46,8	29,9	30	19,1	13	18,8	13,2	7,2
		III. (bar)														40	40	40	29,8	29,6	18,8	13	18,8	13	7,2	
	Operating time	(s)													79		79		79	132	132	171				
	Operating speed	(mm/s)	0,38																							

Further operating speeds: refer to data sheet ARI-PREMIO/PREMIO-Plus 2G

$$\text{Operating time [s]} = \frac{\text{Travel [mm]}}{\text{Operating speed [mm/s]}}$$

- I. Fig. 470: PTFE-V-ring unit / EPDM-sealing
- II. Fig. 470: PTFE- / pure graphite-packing
- III. Fig. 471: Bellows seal

¹⁾ max. differential pressure drop

²⁾ Based on a frequency of 50Hz the control speed and power consumption of the synchronous motors PREMIO 2,2kN are 20% higher at frequency of 60 Hz.

Control valve in straightway form with electric actuator AUMA

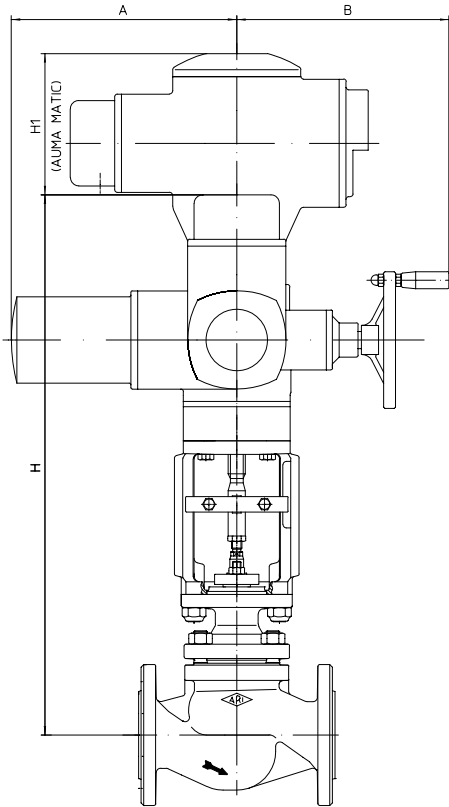

Fig. 470

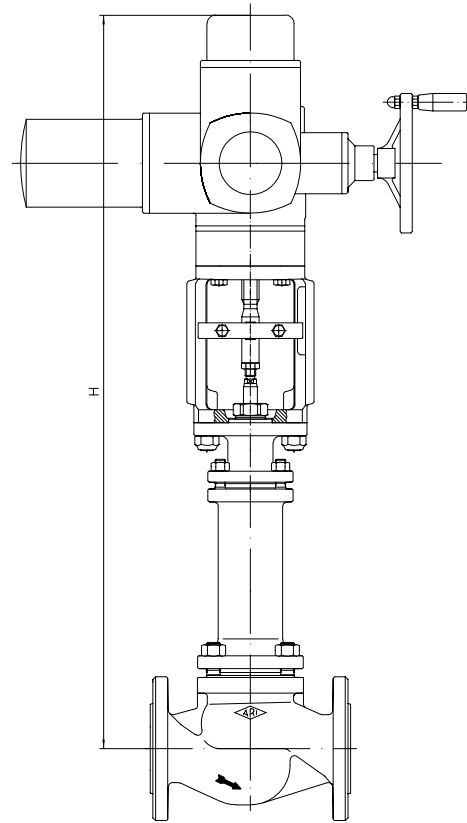

Fig. 471

Actuator data		SAR 07.2	SAR 07.6	SAR 10.2	SAR 14.2	SAR 14.6
A	(mm)	265		283	389	
B	(mm)	249		254	336	339
H1 (AUMA MATIC)	(mm)	130			182	
Supply voltage: 400V 50Hz 3~ (Other voltages on request)						
Technical data for actuator refer to price list.						

Heights and weights

DN	25	40	50	80	100	150	200		
NPS	1"	1 1/2"	2"	3"	4"	6"	8"		
Fig. 470	SAR 07.2 SAR 07.6	H (mm)	652	683	683	712	714	774	869
		ANSI150 (kg)	37	45	47	63	81	131	236
		ANSI300 (kg)	38	48	50	70	95	156	252
	SAR 10.2	H (mm)	--	--	--	714	716	776	871
		ANSI150 (kg)	--	--	--	65	84	134	235
		ANSI300 (kg)	--	--	--	72	98	159	251
	SAR 14.2	H (mm)	--	--	--	--	--	869	944
		ANSI150 (kg)	--	--	--	--	--	174	270
		ANSI300 (kg)	--	--	--	--	--	199	286
	SAR 14.6 LE100	H (mm)	--	--	--	--	--	1127	1202
		ANSI150 (kg)	--	--	--	--	--	219	315
		ANSI300 (kg)	--	--	--	--	--	244	331
Fig. 471	SAR 07.2 SAR 07.6	H (mm)	809	894	894	912	942	1101	1314
		ANSI150 (kg)	40	45	48	65	85	134	222
		ANSI300 (kg)	41	48	50	70	95	156	252
	SAR 10.2	H (mm)	--	--	--	914	944	1103	1316
		ANSI150 (kg)	--	--	--	67	88	137	225
		ANSI300 (kg)	--	--	--	74	96	159	240
	SAR 14.2	H (mm)	--	--	--	--	--	1428	--
		ANSI150 (kg)	--	--	--	--	--	207	--
		ANSI300 (kg)	--	--	--	--	--	232	--

For version with AUMA SAR Ex other heights.

Further dimensions refer to pages 18-23.



Fig. 470	DN		25	40			50			80			100			150			200					
	NPS		1"	1 1/2"			2"			3"			4"			6"			8"					
Parabolic plug	Kvs-value		(m³/h)	10	10	16	25	16	25	40	40	63	100	63	100	160	160	250	400	--				
	max. diff. pressure ¹⁾		(bar)	40	40			30	40	30			30	15	8	15	8	4	4	2			--	
V-port plug	Kvs-value		(m³/h)	--	--			--			63			100	63	100	160	160	250	400	250	400	630	
	max. diff. pressure ¹⁾		(bar)	--	--			--			30			30			25	25	15			15	12	
Perforated plug	Kvs-value		(m³/h)	6,3	6,3	10	16	10	16	25	25	40	63	40	63	100	100	160	250	160	250	400		
	max. diff. pressure ¹⁾		(bar)	40	40			40			40			40			40			40	30			
Seat-Ø			(mm)	25	25	32	40	32	40	50	50	65	80	65	80	100	100	125	150	125	150	200		
Travel			(mm)	20	20	30	20	30			30			30			30	50	50	50	65			
SAR 07.2 Output drive Form A TR 20 x 4 - LH	Closing pressure	I./II.	shut off	(bar)	51	51			51	51	51	46,4	30,6	46,4	30,6	19,4								
			controlling ²⁾	(bar)	51	51			37,6	37,6	21,9	14,3	21,9	14,3	9									
	Torque			(Nm)	15	15			15	20	20	30			30									
	Operating time (50 Hz)			(s)	54	54	56	54	56	56			56											
Output drive			(rpm)	5,6	5,6	8	5,6	8	8			8												
SAR 07.6 Output drive Form A TR 26 x 5 - LH	Closing pressure	I./II.	shut off	(bar)							51	51	43,1	51	43,1	27,5	27,5	17,5	12	17,3	11,9	6,6		
			controlling ²⁾	(bar)							51	51	31,3	20,6	31,3	20,6	13	13	8,2	5,6	8	5,5	2,9	
	Torque			(Nm)							30	30	50	60	50	60			60			60		
	Operating time (50 Hz)			(s)							64	64			64			64	55	55	71			
Output drive			(rpm)							5,6	5,6			5,6			5,6	11	11					
SAR 10.2 Output drive Form A TR 26 x 5 - LH	Closing pressure	I./II.	shut off	(bar)							51	51	51	51	41,9	41,9	26,8	18,5	35,8	24,8	13,9			
			controlling ²⁾	(bar)							51	43,1	51	43,1	27,5	27,5	17,5	12	17,3	11,9	6,6			
	Torque			(Nm)							60	80	60	80	90	90			120					
	Operating time (50 Hz)			(s)							64	64			64	55	55	71						
Output drive			(rpm)							5,6	5,6			5,6	11	11								
SAR 14.2 Output drive Form A TR 30 x 6 - LH	Closing pressure	I./II.	shut off	(bar)													51	51	42,7	51	42,7	24		
			controlling ²⁾	(bar)													45,2	28,9	20	28,9	20	11,1		
	Torque			(Nm)													150	225	250	225	250			
	Operating time (50 Hz)			(s)													38	63	63	59				
Output drive			(rpm)													8			8	11				
SAR 14.6 with LE100.1	Closing pressure	I./II.	shut off	(bar)													51			51	31,7			
			controlling ²⁾	(bar)													51	40	27,7	40	27,7	15,5		
	Torque			(Nm)													250	300	400	300	400	400		
	Operating time (50 Hz)			(s)													46	54	54	51				
Output drive			(rpm)													5,6	8	8	11					

I. Fig. 470: PTFE-V-ring unit / EPDM-sealing
II. Fig. 470: PTFE- / pure graphite-packing

¹⁾ max. differential pressure drop

²⁾ Restrictions through max. permissible torque of the actuator at controlling operation.



Fig. 471	DN		25	40			50			80			100			150			200			
	NPS		1"	1 1/2"			2"			3"			4"			6"			8"			
Parabolic plug	Kvs-value	(m³/h)	10	10	16	25	16	25	40	40	63	100	63	100	160	160	250	400	--			
	max. diff. pressure ¹⁾	(bar)	40	40			30	40	30	30	15	8	15	8	4	4	2			--		
V-port plug	Kvs-value	(m³/h)	--	--			--			--	63	100	63	100	160	160	250	400	250	400	630	
	max. diff. pressure ¹⁾	(bar)	--	--			--			--	30			30	25	25	15			15	12	
Perforated plug	Kvs-value	(m³/h)	6,3	6,3	10	16	10	16	25	25	40	63	40	63	100	100	160	250	160	250	400	
	max. diff. pressure ¹⁾	(bar)	40	40			40			40			40			40			40	30		
Seat-Ø			(mm)	25	25	32	40	32	40	50	50	65	80	65	80	100	100	125	150	125	150	200
Travel			(mm)	20	20		30	20	30	30			30			30	50			50	50	65
SAR 07.2 Output drive Form A TR 20 x 4 - LH	Closing pressure	III.	shut off	(bar)	40	40			40	40	40	30,4	40	30,4	19,4							
			controlling ²⁾	(bar)	40	40			40	37,1	37,1	21,7	14,2	21,7	14,2	8,9						
	Torque	(Nm)	15	15			15	20	20	30			30									
	Operating time (50 Hz)	(s)	54	54	56	54	56	56			56											
	Output drive	(rpm)	5,6	5,6	8	5,6	8	8			8											
SAR 07.6 Output drive Form A TR 26 x 5 - LH	Closing pressure	III.	shut off	(bar)					40	40			40	27,4	27,2	17,3	11,9	17,3	11,9	6,6		
			controlling ²⁾	(bar)					40	40	31,2	20,4	31,2	20,4	12,9	12,7	8	5,5	8	5,5	3	
	Torque	(Nm)						30	30	40	60	40	60	60			60					
	Operating time (50 Hz)	(s)						64	64			64			64	55	55	71				
	Output drive	(rpm)						5,6	5,6			5,6			5,6	11	11					
SAR 10.2 Output drive Form A TR 26 x 5 - LH	Closing pressure	III.	shut off	(bar)							40	40	32,2	40	29,7	20,5	26,6	18,4	10,2			
			controlling ²⁾	(bar)							40	40	27,4	27,2	17,3	11,9	17,3	11,9	6,6			
	Torque	(Nm)								60	60	70	90	100	90							
	Operating time (50 Hz)	(s)								64	64			64	55	55	71					
	Output drive	(rpm)								5,6	5,6			5,6	11	11						
SAR 14.2 Output drive Form A TR 30 x 6 - LH	Closing pressure	III.	shut off	(bar)											40	33,9						
			controlling ²⁾	(bar)												40	28,8	19,9				
	Torque	(Nm)													120	175	200					
	Operating time (50 Hz)	(s)													38	63						
	Output drive	(rpm)													8							

III. Fig. 471: Bellows seal

¹⁾ max. differential pressure drop

²⁾ Restrictions through max. permissible torque of the actuator at controlling operation.



Control valve in straightway form with flanges

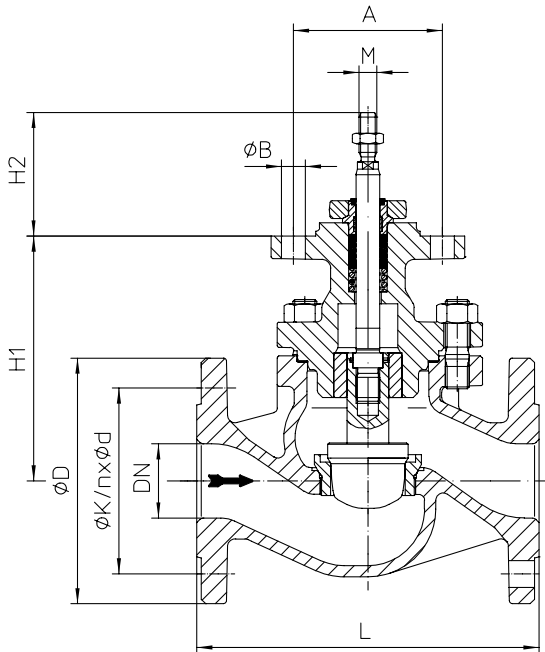

Fig. 470...90

DN25-150 / NPS 1"-6"
(e.g.: DP32-34; PREMIO 2,2-25kN; AUMA 07.2-10.2)

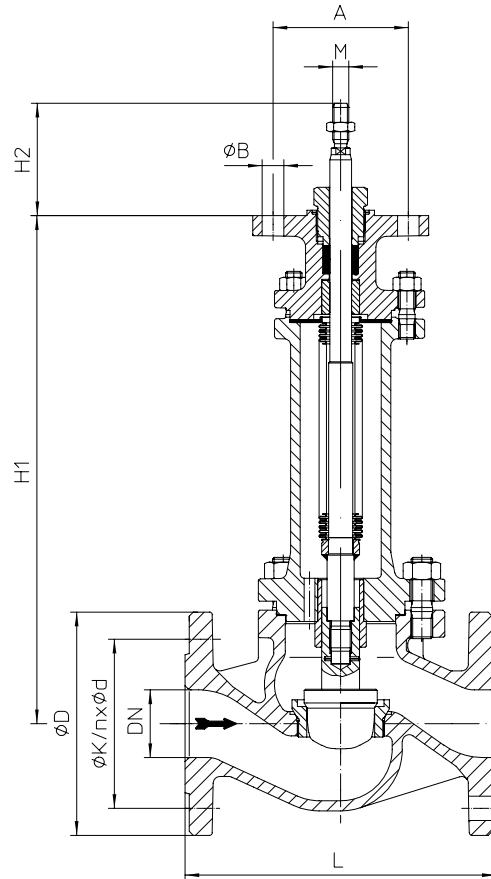

Fig. 471...90

DN25-150 / NPS 1"-6"
(e.g.: DP32-34; PREMIO 2,2-25kN; AUMA 07.2-10.2)

DN	25	40	50	80	100	150
NPS	1"	1 1/2"	2"	3"	4"	6"

Dimensions								
M	Fig. 470	(mm)	M10	M12		M16 x 1,5		
	Fig. 471	(mm)		M12		M14 x 1,5		M16 x 1,5
H1	Fig. 470	(mm)	134	165	165	194	196	256
	Fig. 471	(mm)	291	376	376	394	424	583
H2	Fig. 470 / Fig. 471	(mm)	83					
A	Fig. 470 / Fig. 471	(mm)	100					
ØB	Fig. 470 / Fig. 471	(mm)	2 x 16					

Face-to-face dimension Form RF acc. to ANSI / ISA S75.08.01-2016			(Face-to-face dimension for Form RTJ refer to page 26.)					
L	ANSI150	(mm)	184	222	254	298	352	451
	ANSI300	(mm)	197	235	267	318	368	473

Flanges acc. to ANSI B16.5								
ØD	ANSI150	(mm)	110	125	150	190	230	280
	ANSI300	(mm)	124	155	165	210	254	318
ØK	ANSI150	(mm)	79	98	121	152	191	241
	ANSI300	(mm)	89	114	127	168	200	270
n x Ød	ANSI150	(mm)	4 x 16	4 x 16	4 x 19	4 x 19	8 x 19	8 x 22
	ANSI300	(mm)	4 x 19	4 x 22	8 x 19	8 x 22	8 x 22	12 x 22

Weights								
Fig. 470	ANSI150	(kg)	9	16	18	34	52	102
	ANSI300	(kg)	11	19	21	41	66	127
Fig. 471	ANSI150	(kg)	13	17	19	36	56	105
	ANSI300	(kg)	14	20	22	43	64	130

max. permissible thrust								
Fig. 470	(kN)	12,7	18,2		40,6			
Fig. 471	(kN)	18,2		29,6			40,6	

Control valve in straightway form with flanges

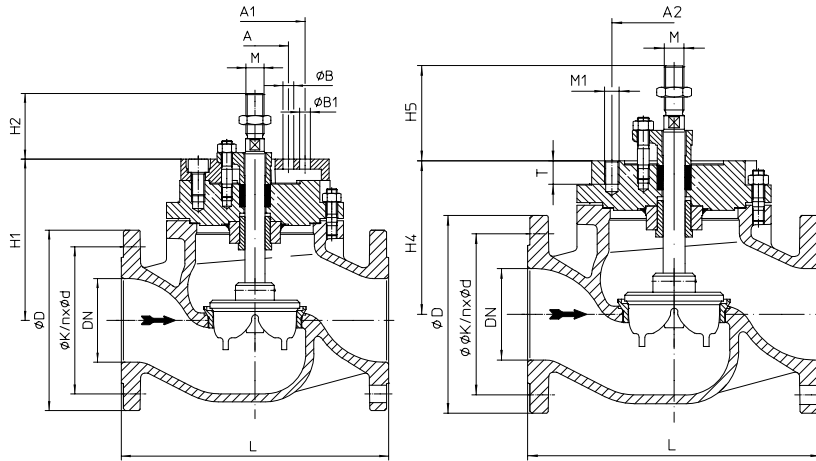

Fig. 470...90
DN200 / NPS 8"
(e.g.: DP34, PREMIO 5-25kN)

Fig. 470...90
DN200 / NPS 8"
(e.g.: AUMA 07.6-10.2)

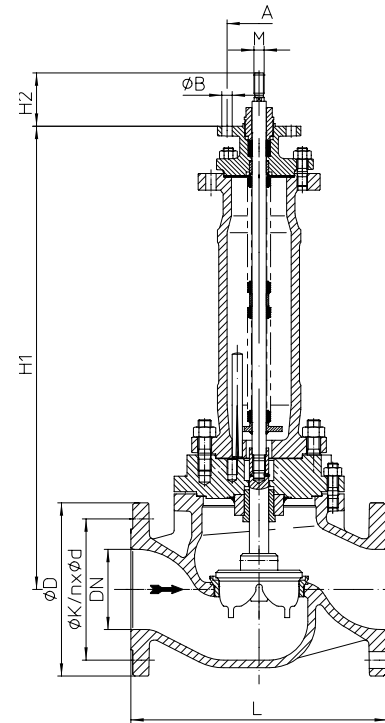

Fig. 471...90
DN200 / NPS 8" M16
(e.g.: PREMIO 5-25kN, AUMA 07.6-10.2)

DN	200
NPS	8"

Dimensions			
M	Fig. 470	(mm)	M20
	Fig. 471	(mm)	M16 M20
H1	Fig. 470	(mm)	315
	Fig. 471	(mm)	796 722
H2	Fig. 470	(mm)	98
	Fig. 471	(mm)	83 98
H4	Fig. 470	(mm)	283
H5	Fig. 470	(mm)	130
A	Fig. 470 / Fig. 471	(mm)	100
ØB	Fig. 470	(mm)	2 x 16
A1	Fig. 470 / Fig. 471	(mm)	150
ØB1	Fig. 470 / Fig. 471	(mm)	4 x 16
A2	Fig. 470	(mm)	170
M1	Fig. 470	(mm)	M20
T	Fig. 470	(mm)	32

Face-to-face dimension Form RF acc. to ANSI / ISA S75.08.01-2016 (Face-to-face dimension for Form RTJ refer to page 26.)			
L	ANSI150	(mm)	543
	ANSI300	(mm)	568

Flanges acc. to ANSI B16.5			
ØD	ANSI150	(mm)	345
	ANSI300	(mm)	381
ØK	ANSI150	(mm)	298
	ANSI300	(mm)	330
n x Ød	ANSI150	(mm)	8 x 22
	ANSI300	(mm)	12 x 25

Weights			
Fig. 470	ANSI150	(kg)	203
	ANSI300	(kg)	193
Fig. 471	ANSI150	(kg)	202 201
	ANSI300	(kg)	219 218

max. permissible thrust			
Fig. 470		(kN)	59,1
Fig. 471		(kN)	34

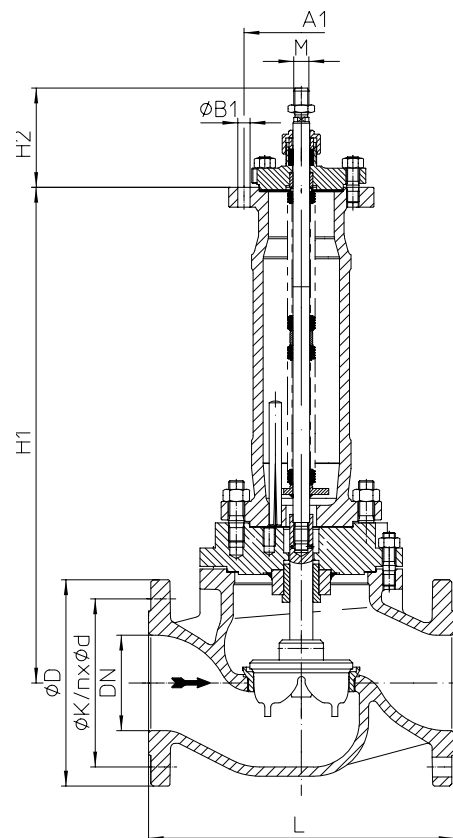

Fig. 471...90
DN200 / NPS 8" M20
(e.g.: DP34-34Tri)

Control valve in straightway form with flanges

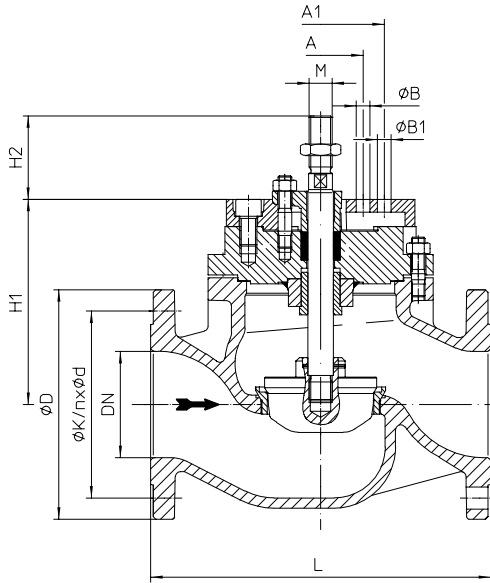

Fig. 470...90

DN150-200 / NPS 6"-8"
(e.g.: DP34T-34Tri)

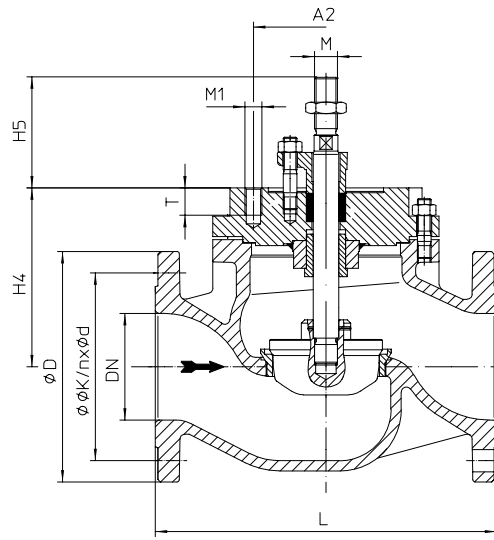

Fig. 470...90

DN150-200 / NPS 6"-8"
(e.g.: DP35; AUMA 14.2-14.6)

DN	150	200
NPS	6"	8"

Dimensions				
M	Fig. 470	(mm)	M27	
	Fig. 471	(mm)	M27	--
H1	Fig. 470	(mm)	278	315
	Fig. 471	(mm)	722	--
H2	Fig. 470	(mm)	98	
	Fig. 471	(mm)	185	--
H4	Fig. 470	(mm)	240	283
H5	Fig. 470	(mm)	130	
A	Fig. 470	(mm)	100	
ØB	Fig. 470	(mm)	16	
A1	Fig. 470	(mm)	150	
	Fig. 471	(mm)	150	--
ØB1	Fig. 470	(mm)	16	
	Fig. 471	(mm)	16	--
A2	Fig. 470	(mm)	170	
M1	Fig. 470	(mm)	M20	
T	Fig. 470	(mm)	32	

Face-to-face dimension Form RF acc. to ANSI / ISA S75.08.01-2016
(Face-to-face dimension for Form RTJ refer to page 26.)

L	ANSI150	(mm)	451	543
	ANSI300	(mm)	473	568

Flanges acc. to ANSI B16.5

ØD	ANSI150	(mm)	280	345
	ANSI300	(mm)	318	381
ØK	ANSI150	(mm)	241	299
	ANSI300	(mm)	270	330
n x Ød	ANSI150	(mm)	8 x 22	8 x 22
	ANSI300	(mm)	12 x 22	12 x 26

Weights

Fig. 470	ANSI150	(kg)	107	203
	ANSI300	(kg)	132	219
Fig. 471	ANSI150	(kg)	188	--
	ANSI300	(kg)	203	--

max. permissible thrust

Fig. 470	(kN)	112
Fig. 471	(kN)	70

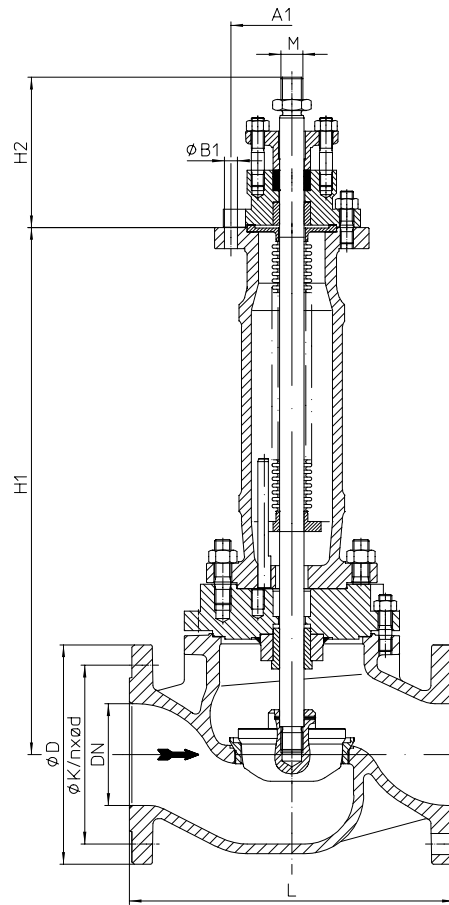

Fig. 471...90

DN150 / NPS 6"
(e.g.: DP34T-35; AUMA 14.2)



Control valve in straightway form with butt weld ends

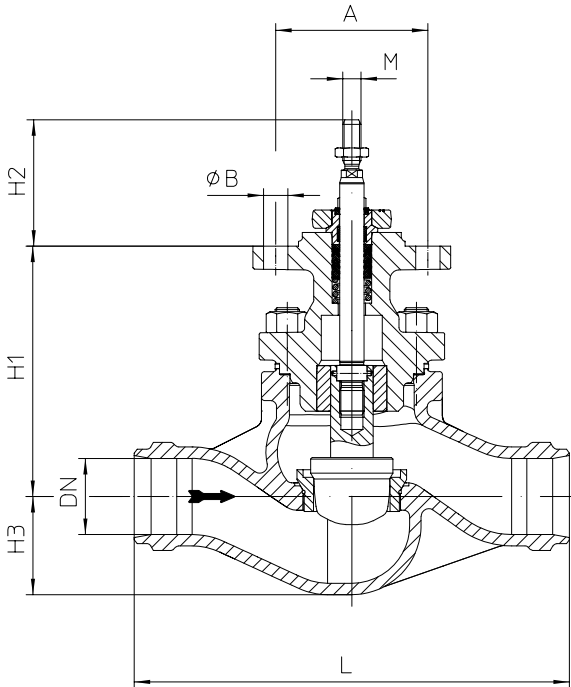

Fig. 470...4...90

DN25-150 / NPS 1"-6"

(e.g.: DP32-34; PREMIO 2,2-25kN; AUMA 07.2-10.2)

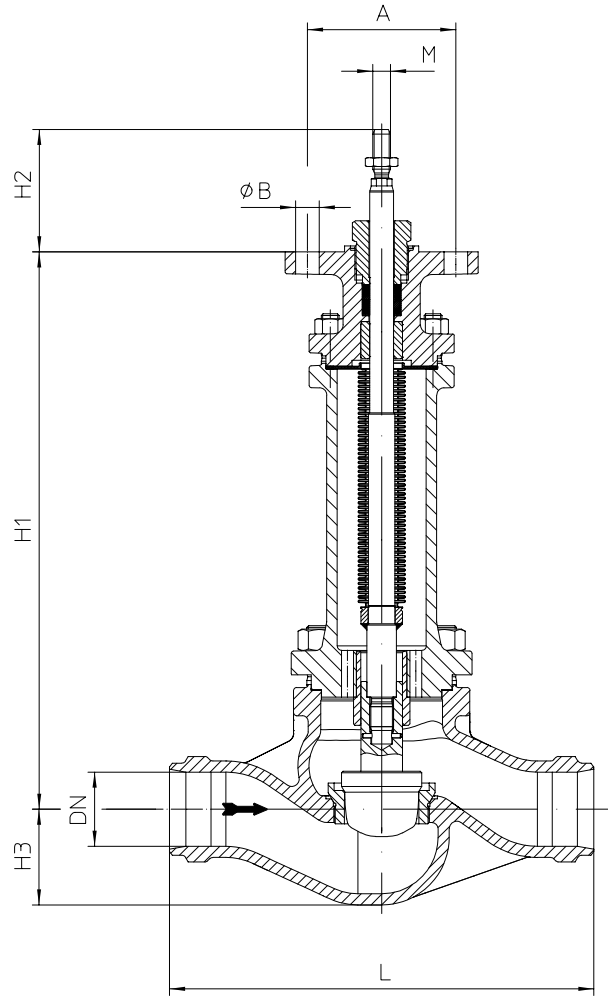

Fig. 471...4...90

DN25-150 / NPS 1"-6"

(e.g.: DP32-34; PREMIO 2,2-25kN; AUMA 07.2-10.2)

DN	25	40	50	80	100	150
NPS	1"	1 1/2"	2"	3"	4"	6"

Dimensions			M10	M12	M16 x 1,5			
M	Fig. 470	(mm)	M10			M12		
	Fig. 471	(mm)	M12			M16 x 1,5		
H1	Fig. 470	(mm)	134	165	165	194	196	
	Fig. 471	(mm)	291	376	376	394	424	
H2	Fig. 470 / 471	(mm)	83					
H2	Fig. 470 / 471	(mm)	50	70	70	100	115	
A	Fig. 470 / 471	(mm)	100					
ØB	Fig. 470 / 471	(mm)	16					

Face-to-face dimension according to ANSI / ISA - 75.08.05-2016			210	251	286	337	394	508
L	(mm)							

Butt weld ends similar to ANSI B16.25 (refer to page 27)

Weights			8	14	15	28	43	82
Fig. 470	ANSI300	(kg)						
Fig. 471	ANSI300	(kg)						

max. permissible thrust			12,7	18,2	40,6		
Fig. 470	(kN)						
Fig. 471	(kN)						

Control valve in straightway form with butt weld ends

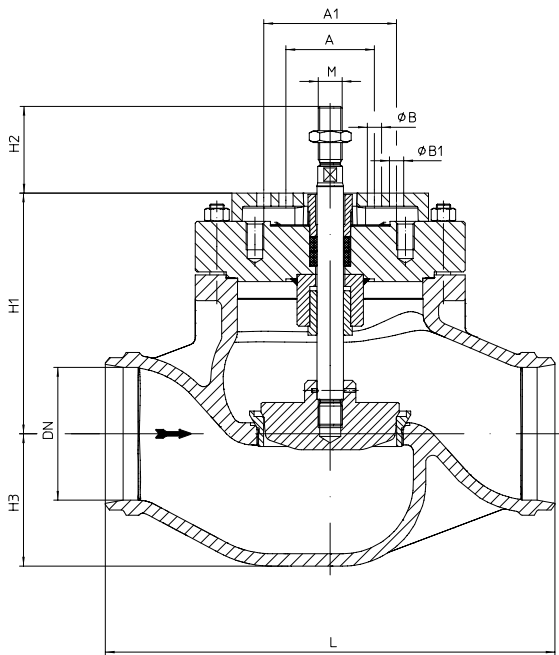

Fig. 470...4...90
DN150 / NPS 6"
(e.g.: DP34T-34Tri)

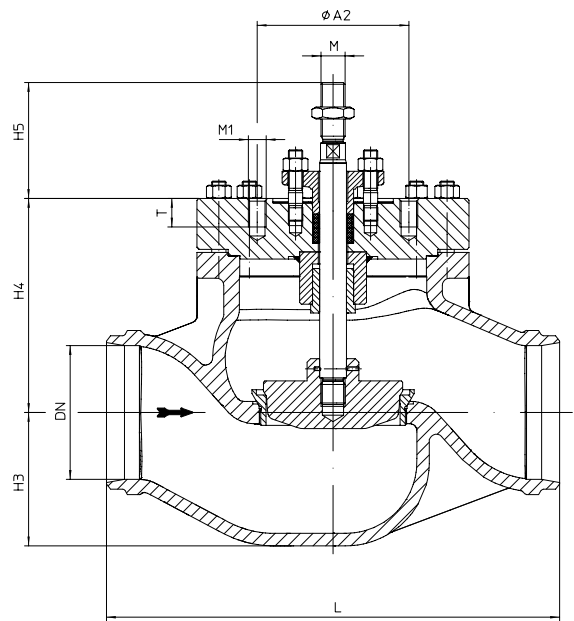

Fig. 470...4...90
DN150 / NPS 6"
(e.g.: DP35; AUMA 14.2-14.6)

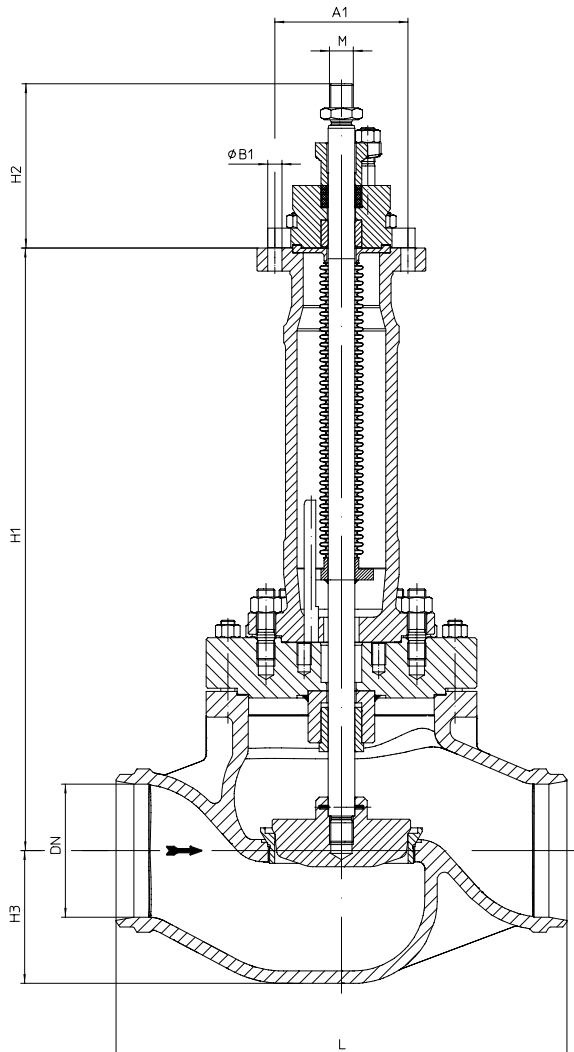

Fig. 471...4...90
DN150 / NPS 6"
(e.g.: DP34T-35; AUMA 14.2)

DN	150
NPS	6"

Dimensions			
M	Fig. 470 / 471	(mm)	M27
H1	Fig. 470	(mm)	272
	Fig. 471	(mm)	679
H2	Fig. 470	(mm)	98
	Fig. 471	(mm)	185
H3	Fig. 470 / 471	(mm)	160
H4	Fig. 470	(mm)	240
H5	Fig. 470	(mm)	130
A	Fig. 470	(mm)	100
n x ØB	Fig. 470	(mm)	2 x 16
A1	Fig. 470 / 471	(mm)	150
n x ØB1	Fig. 470 / 471	(mm)	4 x 16
A2	Fig. 470	(mm)	170
n x M1	Fig. 470	(mm)	8 x M20
T	Fig. 470	(mm)	32

Face-to-face dimension according to ANSI / ISA - 75.08.05-2016		
L	(mm)	508
Butt weld ends similar to ANSI B16.25 (refer to page 27)		

Weights			
Fig. 470	ANSI300	(kg)	98
Fig. 471	ANSI300	(kg)	131

max. permissible thrust			
Fig. 470	(kN)		112
Fig. 471	(kN)		70

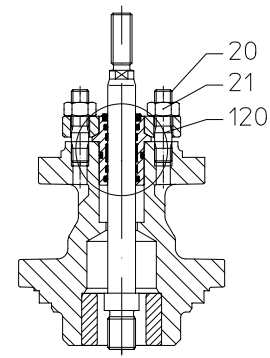
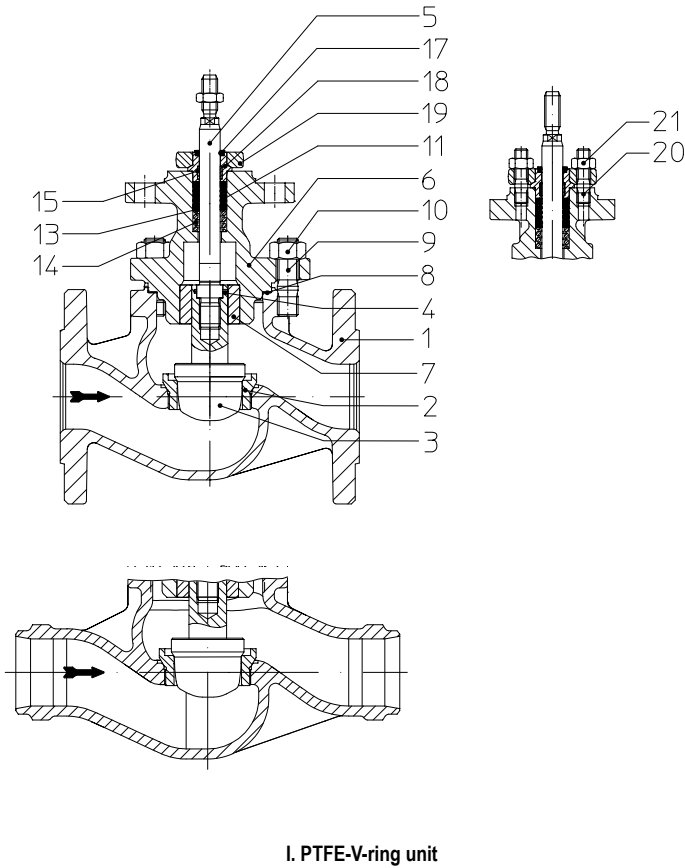

I. EPDM-sealing

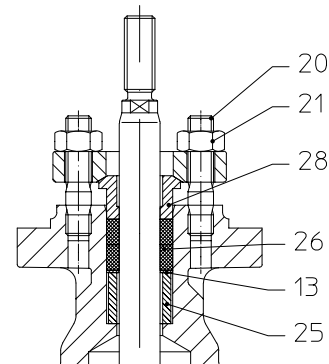

II. PTFE- / pure graphite-packing

Pos.	Sp.p.	Description	Fig. 32.470...90 / Fig. 35.470...90	Fig. 55.470....90
1		Body	SA216WCB	SA351CF8M
2	x	Seat ring	SA276Gr.420 ¹⁾	SA479Gr.316Ti
3	x	Plug	SA276Gr.420 ¹⁾	SA479Gr.316Ti
4	x	Clamping sleeve	A2	
5	x	Spindle	SA276Gr.420 ¹⁾	SA479Gr.316Ti
6		Mounting bonnet	SA216WCB	SA351CF8M
7		Guide bushing	SA276Gr.420 ¹⁾ (hardened)	SA479Gr.316Ti
8	x	Gasket	Pure graphite (CrNi laminated with graphite)	
9		Stud	SA193-B7	SA193B8M2 (DN100-150: SA453 Gr.660)
10		Hexagon nuts	SA194-2H	SA194-8M (DN100-150: SA453 Gr.660)
11	Set: refer to Pos. 100	V-ring unit	PTFE	
13		Washer	SA240Gr.304	
14		Compression spring	AISI301 A313Gr.301	
15		Guide bush	PTFE25%C	
17		Scraper	PTFE	
18		Stem guiding	AISI303	
19		Packing box flange	SA105	SA479Gr.316Ti
20		Stud	A4-70	SA193B8M2
21		Hexagon nuts	A4	SA194-8M
25	x	Distance bush	SA276Gr.420 ¹⁾	SA479Gr.316Ti
26	x	Packing ring	PTFE or Pure graphite	
28	x	Packing follower	SA276Gr.420 ¹⁾	SA479Gr.316Ti

Stem sealings Fig. 470...90				
100	x	V-ring unit (set)	Set of: Pos. 11, 13, 14, 15, 17, 18	
120	x	EPDM-sealing, cpl.	EPDM / AISI303	
26	x	Packing ring	PTFE / SA276Gr.420 ¹⁾	
26	x	Packing ring	Pure graphite / SA276Gr.420 ¹⁾	
		L Spare parts		

¹⁾ Heat treatment acc. to EN

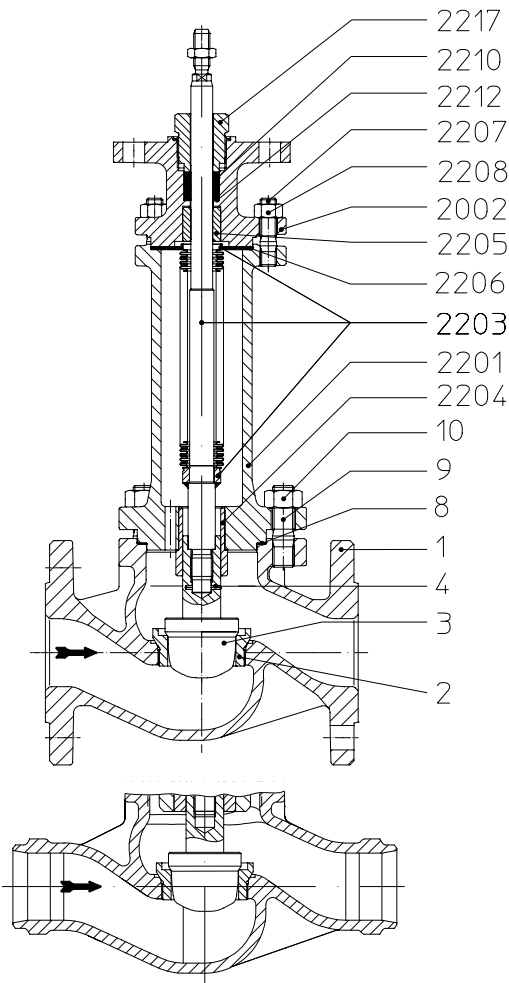

III. Stainless steel bellows seal with PTFE-packing / Pure graphite-packing

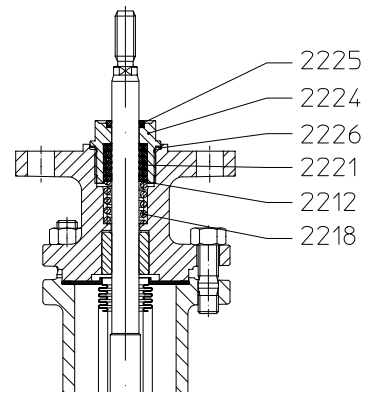

III. Stainless steel-bellows with V-ring unit

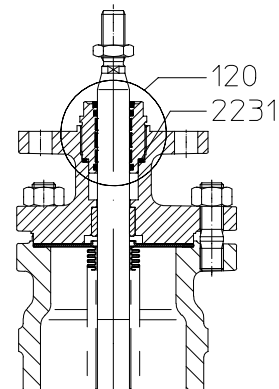

III. Stainless steel bellows seal with EPDM-sealing

Pos.	Sp.p.	Description	Fig. 32.471...90 / Fig. 35.471...90
1		Body	SA216WCB
2	x	Seat ring	SA276Gr.420 ¹⁾
3	x	Plug	SA276Gr.420 ¹⁾
4	x	Clamping sleeve	A2
8	x	Gasket	Pure graphite (CrNi laminated with graphite)
9		Stud	SA193-B7
10		Hexagon nuts	SA194-2H
2201		Bellows housing	SA216WCB
2202		Mounting bonnet	SA216WCB
2203	x	Stem- / Bellows unit	SA276Gr.420 ¹⁾ / SA240Gr.321
2204		Guide bushing	SA276Gr.420 ¹⁾ (hardened)
2205		Guide bushing	SA276Gr.420 ¹⁾ (hardened)
2206	x	Gasket	Pure graphite (CrNi laminated with graphite)
2207		Stud	SA193-B7
2208		Hexagon nuts	SA194-2H
2210	x	Packing ring	Pure graphite
2212	x	Washer	SA240Gr.304
2217	x	Screw joint	AISI303
2218		Compression spring	AISI301
2212	Set: refer to Pos. 100	Washer	SA240Gr.304
2221		V-ring unit	PTFE
2224		Screw joint	AISI303
2225		Scraper	PTFE
2226		Gasket	SA479Gr.316Ti
2231	x	Gasket	Cu

Stem sealings Fig. 471...90			
2010	x	Packing ring	Pure graphite or PTFE
100	x	V-ring unit (set)	Set of: Pos. 2212, 2218, 2221, 2224, 2225, 2226
120	x	EPDM-sealing, cpl.	EPDM / AISI303
		L Spare parts	

¹⁾ Heat treatment acc. to EN

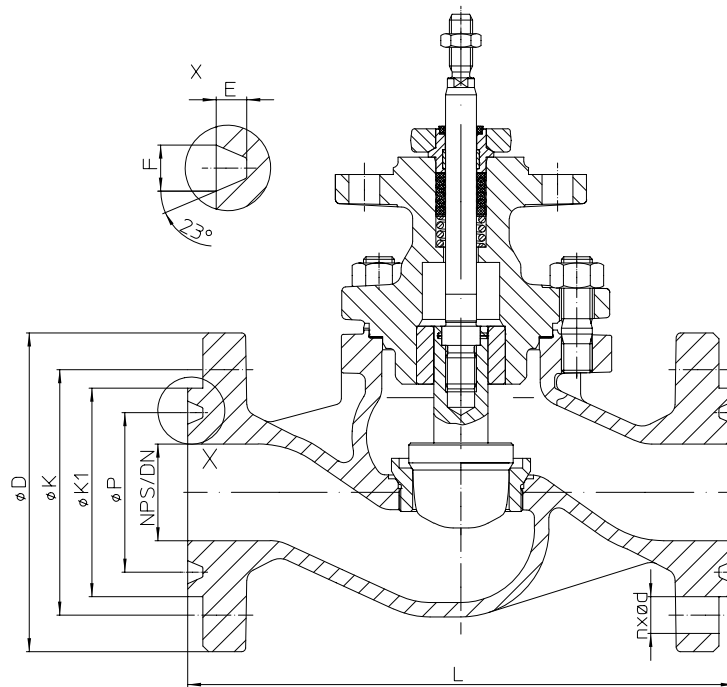

DN	25	40	50	80	100	150	200
NPS	1"	1 1/2"	2"	3"	4"	6"	8"

Face-to-face dimension Form RTJ									
L	ANSI150	(mm)	197	235	267	311	365	464	556
	ANSI300	(mm)	210	248	283	334	384	489	584

Flanges acc. to ANSI B16.5 (Ring-Joint Facing)									
øP	ANSI150	(mm)	47,6	65,1	82,6	114	149	194	248
	ANSI300	(mm)	50,8	68,3	82,6	124	149	211	270
E	ANSI150	(mm)	6,4	6,4	6,4	6,4	6,4	6,4	6,4
	ANSI300	(mm)	6,4	6,4	7,9	7,9	7,9	7,9	7,9
F	ANSI150	(mm)	8,7	8,7	8,7	8,7	8,7	8,7	8,7
	ANSI300	(mm)	8,7	8,7	11,9	11,9	11,9	11,9	11,9
ø K1	ANSI150	(mm)	63,5	82,5	102	133	171	219	273
	ANSI300	(mm)	70	90,5	108	146	175	241	302
øD	ANSI150	(mm)	110	125	150	190	230	280	345
	ANSI300	(mm)	124	155	165	210	254	318	381
øK	ANSI150	(mm)	79	98	121	152	191	241	299
	ANSI300	(mm)	89	114	127	168	200	270	330
n x ød	ANSI150	(n x mm)	4 x 16	4 x 16	4 x 19	4 x 19	8 x 19	8 x 22	8 x 22
	ANSI300	(n x mm)	4 x 19	4 x 22	8 x 19	8 x 22	8 x 22	12 x 22	12 x 26

L = Face-to-face dimension

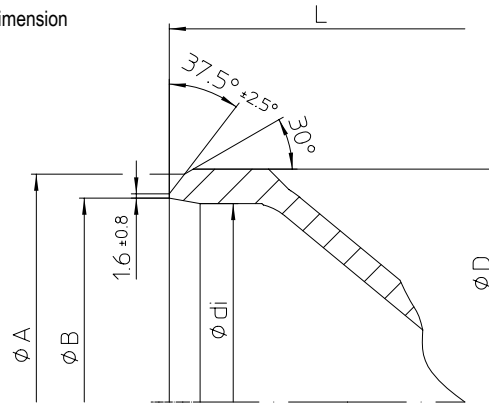

DN	25	40	50	80	100	150
NPS	1"	1 1/2"	2"	3"	4"	6"

Butt weld ends similar to ANSI B16.25 (Schedule 40)								
L	Fig. 470 / 471	(mm)	210	251	286	337	394	508
ØA	Fig. 470 / 471	(mm)	33,5	48,3	60,4	91,3	117,5	172,2
ØB	Fig. 470 / 471	(mm)	26,7	40,9	52,5	77,9	102,3	154,1
Ødi	Fig. 470 / 471	(mm)	25	40	50	80	100	150
ØD	Fig. 470 / 471	(mm)	40	57	67	100	125	176

Butt weld ends similar to ANSI B16.25 (Schedule 80)								
L	Fig. 470 / 471	(mm)	210	251	286	337	394	508
ØA	Fig. 470 / 471	(mm)	33,5	48,3	60,4	91,3	117,5	172,2
ØB	Fig. 470 / 471	(mm)	24,3	38,1	49,3	73,7	97,2	146,4
Ødi	Fig. 470 / 471	(mm)	25	40	50	80	100	150
ØD	Fig. 470 / 471	(mm)	40	57	67	100	125	176

Face-to-face dimension according to ANSI / ISA - 75.08.05-2016

Butt weld ends similar to ANSI B16.25 (Schedule 40 or Schedule 80)

The material used for ARI valves with butt weld ends are: SA216WCB acc. to ANSI B16.5

Based on our experience we recommend electric welding process for connecting valves or strainers with tubes or with each other.

Lime based electrodes with an appropriate composite material should be used as filler material for welding.

Gas welding should be avoided.

Because of the different material compositions and wall thickness of the steam traps and the pipe gas welding shall not be applied. Quenching cracks and coarse grain structure may develop.



Your valve made by ARI®
ari-armaturen.com

ARI-STEVI® 470 / 471 - ANSI (DN25-200)

Notes



Your valve made by ARI®
ari-armaturen.com

ARI-Armaturen Albert Richter GmbH & Co. KG, D-33750 Schloß Holte-Stukenbrock,
Tel. +49 52 07 / 994-0, Telefax +49 52 07 / 994-158 or 159 Internet: <https://www.ari-armaturen.com> E-mail: info.vertrieb@ari-armaturen.com