



## 2/2-way diaphragm valve with manually operated actuator

- Diaphragm body made of PP, PVC-U and PVDF
- Self-draining plastic valve body with socket, spigot or flange connection
- Suitable for aggressive and corrosive media

Product variants described in the data sheet may differ from the product presentation and description.

### Can be combined with

	<b>Type SV02</b> Diaphragms	▶
	<b>Type 2973</b> 2/2-way diaphragm valve with manually operated actuator (FullFunction)	▶
	<b>Type 2933</b> 2/2-way diaphragm valve with manually operated actuator (basic)	▶
	<b>Type 2103</b> 2/2-way diaphragm valve with pneumatic stainless steel actuator (Type ELEMENT) for decentralised automation	▶
	<b>Type 2036</b> Robolux multiway diaphragm valve, pneumatically operated	▶
	<b>Type 8098</b> FLOWave SAW flowmeter	▶

### Type description

The hand-operated diaphragm valve Type 3232/3233 consists of a hand-operated actuator, a diaphragm and a 2-way body. The manual actuator with plastic handwheel ensures use in hygienic or aggressive ambient conditions. The flow-optimised valve body with minimum dead space enables high flow rates and a wide range of possible applications. The valve bodies are available in PP, PVC-U, PVDF. The membranes are available in the usual materials and designs. The actuator has a compact design and is compatible with all other Bürkert diaphragm valves.

## Table of contents

<b>1. General technical data</b>	<b>3</b>
<hr/>	
<b>2. Approvals and conformities</b>	<b>5</b>
2.1. General notes .....	5
2.2. Conformity .....	5
2.3. Standards .....	5
2.4. Explosion protection.....	5
2.5. Foods and beverages/Hygiene .....	5
2.6. Others .....	6
<hr/>	
<b>3. Materials</b>	<b>6</b>
3.1. Bürkert resistApp .....	6
3.2. Pressure temperature diagram for plastic valve body .....	6
3.3. Material specifications .....	7
3.4. Example of available membrane materials.....	7
<hr/>	
<b>4. Dimensions</b>	<b>8</b>
4.1. Actuator .....	8
Handwheel .....	8
4.2. Forged steel valve body (VS) with welded connection .....	9
4.3. Forged steel valve body (VS) with clamp connection.....	11
4.4. Tube valve body (VP) with welded connection.....	13
4.5. Tube valve body (VP) with clamp connection.....	14
4.6. Tube valve body (VP) with threaded connection .....	15
4.7. Tube valve body (VP) with flange connection.....	16
4.8. Cast valve body (VG) with welded connection .....	17
4.9. Cast valve body (VG) with clamp connection .....	19
4.10. Plastic body (PV, PD, PP) with spigot connection.....	20
4.11. Plastic body (PV, PD, PP) with true union.....	21
4.12. Plastic body (PV, PD, PP) with flange connection.....	22
<hr/>	
<b>5. Performance specifications</b>	<b>23</b>
5.1. Flow characteristics .....	23
Forged steel valve body (VS) .....	23
Tube valve body (VP) .....	23
Cast valve body (VG) .....	24
Plastic body (PV, PD, PP).....	24
5.2. Medium pressure.....	24
<hr/>	
<b>6. Ordering information</b>	<b>25</b>
6.1. Bürkert eShop .....	25
6.2. Bürkert product filter.....	25
6.3. Bürkert Product Enquiry Form.....	25

## 1. General technical data

Product properties	
Dimensions	Further information can be found in chapter "4. Dimensions" on page 8.
<b>Material<sup>1)</sup></b>	
Forged steel valve body (VS) <sup>1)</sup>	Forged material 1.4435 according to BN2 DIN EN 10222 - 5, F316L according to ASTM A182 / A182M and 316 I according to ASME BPE
Tube valve body (VP) <sup>1)</sup>	Stainless steel tube 1.4435-BN2 / UNS S31603 (316L) according to DIN 11866, ASTM A269 / A270, DIN EN 10217 - 7 / 10216 - 5
Cast valve body (VG) <sup>1)</sup>	Investment cast material 1.4435 / 316 I
Plastic body (PV, PD, PP) <sup>1)</sup>	PVC (PVC-U), PP, PVDF
Diaphragm	EPDM (AD) <sup>1)</sup> , PTFE/EPDM (EA) <sup>1)</sup> , Advanced PTFE/EPDM (EU) <sup>1)</sup> , laminate of GYLON® and EPDM (ER) <sup>1)</sup>
Actuator (diaphragm bonnet/ handwheel) Diaphragm size 8...50	PPS/PPS (stainless steel/PPS or stainless steel/stainless steel)
Actuator (diaphragm bonnet/ handwheel) Diaphragm size 65...100	Stainless steel/stainless steel
Diaphragm size	8...100, for tube valve body 8...50, for plastic body 15...100
<b>Standard surface quality<sup>2)</sup></b>	
Forged steel valve body (VS) <sup>1)</sup>	Internally electrically polished: Ra ≤ 0.38 µm (NO17) <sup>1)</sup> (ASME BPE SF4 / DIN HE4) (externally forged surface, electrically polished) Internally mechanically polished: Ra ≤ 0.5 µm (NO14) <sup>1)</sup> (ASME BPE SF1) (externally forged surface)
Tube valve body (VP) <sup>1)</sup>	Internally electrically polished: Ra ≤ 0.38 µm (NO17) <sup>1)</sup> (ASME BPE SF4 / DIN HE4) Internally glass bead blasted: Ra ≤ 1.6 µm (NO05) <sup>1)</sup> (externally glass bead blasted: Ra ≤ 1.6 µm (NO01)) <sup>1)</sup>
Cast valve body (VG) <sup>1)</sup>	Internally electrically polished: Ra ≤ 0.6 µm (NO16) <sup>1)</sup> (ASME BPE SF6) (externally cast surface, electrically polished) Internally mechanically polished: Ra ≤ 0.76 µm (NO06) <sup>1)</sup> (ASME BPE SF3 / DIN H2) (externally cast surface)
<b>Medium data</b>	
Process medium	Neutral gases and fluids, highly purified, sterile, aggressive or abrasive mediums (see <b>resistance chart</b> ▶)
<b>Medium temperature</b>	
EPDM (AD) <sup>1)</sup>	-10...+143 °C (steam sterilisation + 150 °C for 60 min)
PTFE/EPDM (EA) <sup>1)</sup>	-10...+130 °C (steam sterilisation + 140 °C for 60 min)
Advanced PTFE/EPDM (EU) <sup>1)</sup>	-5...+143 °C (steam sterilisation + 150 °C for 60 min)
Laminate of GYLON® and EPDM (ER) <sup>1)</sup>	-5...+130 °C (steam sterilisation + 140 °C for 60 min)
Plastic body	See "3.2. Pressure temperature diagram for plastic valve body" on page 6
<b>Process/Port connection &amp; communication</b>	
Nominal diameter (port connection)	DN 06...DN 100 (1/8"...4")
<b>Port connection<sup>2)</sup> for stainless steel body<sup>3)</sup></b>	
Welded connection <sup>2)</sup>	DIN EN ISO 1127 / ISO 4200 / DIN 11866 series B DIN 11850 - 2 / DIN 11866 series A / DIN EN 10357 series A ASME BPE / DIN 11866 series C
Clamp connection <sup>2)</sup>	DIN 32676 series A (DIN pipe) DIN 32676 series B (ISO pipe) ASME BPE
<b>For plastic body</b>	
Spigot connection	DN 15...DN 50
True union	DN 15...DN 50
Loose flange	DN 15...DN 65
Fixed flange	DN 80...DN 100

### Environment and installation

Installation position See **operating manual Type 3233** ▶

#### Ambient temperature: actuator (diaphragm bonnet/handwheel) <sup>4.)</sup>

PPS/PPS	0...+ 130 °C (short-term up to + 150 °C) <sup>5.)</sup>
Stainless steel/PPS	0...+ 130 °C (short-term up to + 150 °C) <sup>5.)</sup>
Stainless steel/stainless steel	- 10...+ 140 °C (short-term up to + 150 °C) <sup>5.)</sup>

- 1.) This information is part of the product key (see "6.3. Bürkert Product Enquiry Form" on page 25).
- 2.) Further variants are available on request.
- 3.) Tube valve body (VP) also available with flange and threaded connections
- 4.) With plastic housings, a temperature limitation due to housing material is possible.
- 5.) For standard variant

## 2. Approvals and conformities

### 2.1. General notes

- The approvals and conformities listed below must be stated when making enquiries. This is the only way to ensure that the product complies with all required specifications.
- Not all available versions can be supplied with the below mentioned approvals or conformities.



### 2.2. Conformity

In accordance with the Declaration of Conformity, the product is compliant with the EU Directives.



### 2.3. Standards

The applied standards which are used to demonstrate compliance with the EU Directives are listed in the EU-Type Examination Certificate and/or the EU Declaration of Conformity.

### 2.4. Explosion protection

Approval	Description																
 	<p><b>Optional: Explosion protection (valid for the variable code PX51)</b> As a category 2 device suitable for zone 1/21 and zone 2/22.</p> <p><b>ATEX:</b> EPS 18 ATEX 2 008 X II 2G Ex h IIC T4...T2 Gb II 2D Ex h IIC T135 °C...T300 °C Db</p> <p><b>IECEX:</b> IECEX EPS 18.0007X Ex h IIC T4...T2 Gb Ex h IIC T135 °C...T300 °C Db</p> <table border="1"> <thead> <tr> <th>Temperature class</th> <th>T2</th> <th>T3</th> <th>T4</th> </tr> </thead> <tbody> <tr> <td>Permissible surface temperature</td> <td>+ 300 °C</td> <td>+ 200 °C</td> <td>+ 135 °C</td> </tr> <tr> <td>Ambient temperature</td> <td>- 40...+ 130 °C</td> <td>- 40...+ 130 °C</td> <td>- 40...+ 100 °C</td> </tr> <tr> <td>Maximum medium temperature</td> <td>+ 285 °C</td> <td>+ 185 °C</td> <td>+ 125 °C</td> </tr> </tbody> </table>	Temperature class	T2	T3	T4	Permissible surface temperature	+ 300 °C	+ 200 °C	+ 135 °C	Ambient temperature	- 40...+ 130 °C	- 40...+ 130 °C	- 40...+ 100 °C	Maximum medium temperature	+ 285 °C	+ 185 °C	+ 125 °C
Temperature class	T2	T3	T4														
Permissible surface temperature	+ 300 °C	+ 200 °C	+ 135 °C														
Ambient temperature	- 40...+ 130 °C	- 40...+ 130 °C	- 40...+ 100 °C														
Maximum medium temperature	+ 285 °C	+ 185 °C	+ 125 °C														

### 2.5. Foods and beverages/Hygiene

Conformity	Description
	<p><b>3-A Sanitary Standards Inc. (valid for the variable code PE05)</b> The products comply with 3-A Sanitary Standards Inc (3-A SSI) as per certificate.</p>
FDA	<p><b>FDA – Code of Federal Regulations</b> The diaphragms made of EPDM (AD), PTFE/EPDM (EA), Advanced PTFE/EPDM (EU) and laminate of GYLON® and EPDM (ER) comply with the Code of Federal Regulations published by the FDA (Food and Drug Administration, USA).</p>
USP	<p><b>United States Pharmacopeial Convention (USP)</b> The diaphragms made of EPDM (AD), PTFE/EPDM (EA), Advanced PTFE/EPDM (EU) and laminate of GYLON® and EPDM (ER) are tested according to USP Class VI.</p>
	<p><b>EC Regulation 1935/2004 of the European Parliament and of the Council</b> The diaphragms made of EPDM (AD), PTFE/EPDM (EA), Advanced PTFE/EPDM (EU) and laminate of GYLON® and EPDM (ER) are suitable for use with food and beverages (according to EC Regulation 1935/2004/EC).</p>

DTS 1000450617 EN Version: G Status: RL (released | freigegeben | validé) printed: 18.12.2024

## 2.6. Others

Conformity	Description
TA Luft	Technical instruction on air quality control (valid for the variable code PM01)

## 3. Materials

### 3.1. Bürkert resistApp

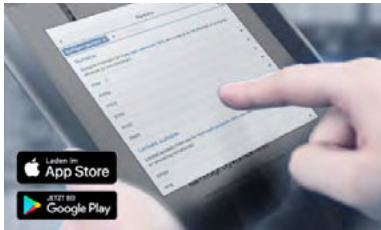

#### Bürkert resistApp – Chemical resistance chart

You want to ensure the reliability and durability of the materials in your individual application case? Verify your combination of media and materials on our website or in our resistApp.

[Start chemical resistance check](#)

### 3.2. Pressure temperature diagram for plastic valve body

**Note:**

This information is important for material selection. Observe the permissible operating pressure depending on the medium temperature.

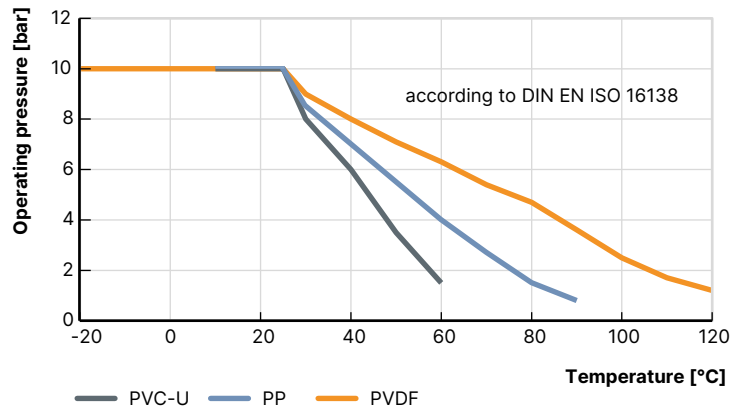

### 3.3. Material specifications

**Note:**

Your product variant may differ from this illustration depending on the housing and interface options.

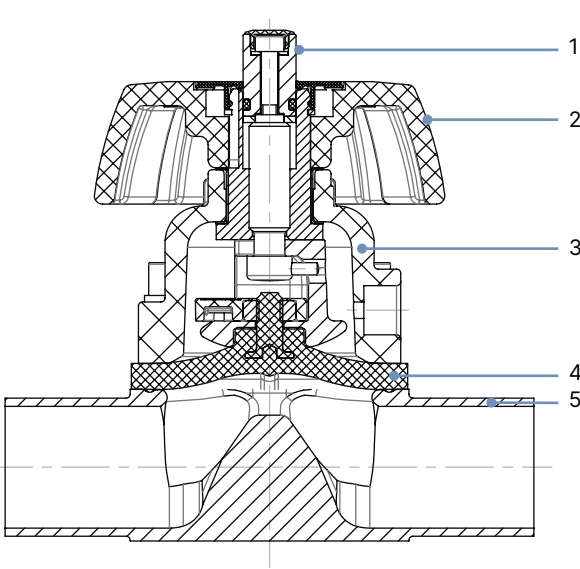

No.	Element	Material
1	Optical position indicator	Diaphragm size 15...50: polyoxymethylene Diaphragm size 65...100: stainless steel
2	Handwheel	Diaphragm size 8...50: polyphenylene sulphide PPS (stainless steel on request) Diaphragm size 65...100: stainless steel
3	Diaphragm bonnet/handwheel	Diaphragm size 8...50: polyphenylene sulphide PPS (stainless steel on request) Diaphragm size 65...100: stainless steel
4	Diaphragm	EPDM (AD), PTFE/EPDM (EA), Advanced PTFE/EPDM (EU), laminate of GYLON® and EPDM (ER)
5	Valve body	See "1. General technical data" on page 3

### 3.4. Example of available membrane materials

The diaphragms have been developed to meet the unique challenges of hygienic and sterile requirements. Bürkert offers diaphragms with precise material composition and high accuracy. Bürkert diaphragms are available in a wide range of materials which have been tested and proven in applications in the food and beverage, biotechnology, pharmaceutical and cosmetics industries. The diaphragms are tested during development and production to ensure reliability under difficult process conditions.



- EPDM (AD)
- PTFE/EPDM (EA)
- Advanced PTFE/EPDM (EU)
- Laminate of GYLON® and EPDM (ER)

For further information please refer to our flyer "Diaphragm competence for hygienic applications" on our [website](#) ►

## 4. Dimensions

### 4.1. Actuator

#### Handwheel

**Note:**

Dimensions in mm, unless otherwise stated

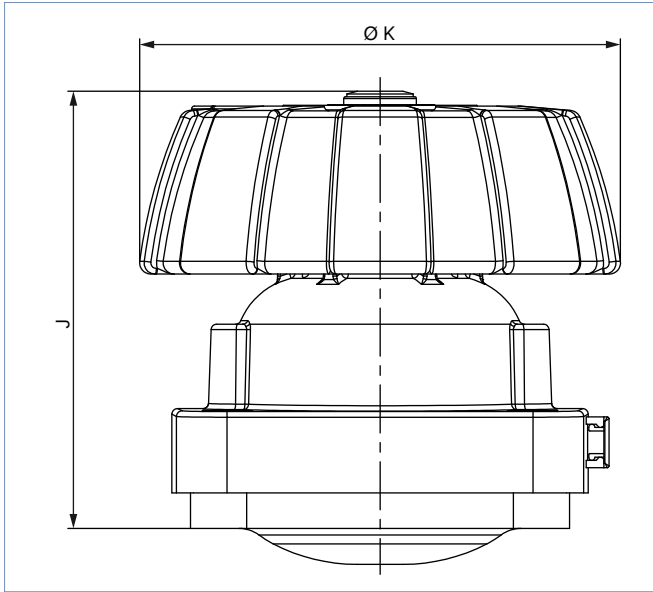

Diaphragm size	Ø K	J
8	35	48
15	85	74
20	86	82
25	86	78
32	114	101
40	114	100
50	114	117
65	272	188
80	272	196
100	272	207

#### 4.2. Forged steel valve body (VS) with welded connection

**Note:**

- Dimensions in mm, unless otherwise stated
- Further information on the draining angle can be found in the “Additional manual Type 2xxx 3xxx” on our website (see **operating instructions Type 3233** ▶).

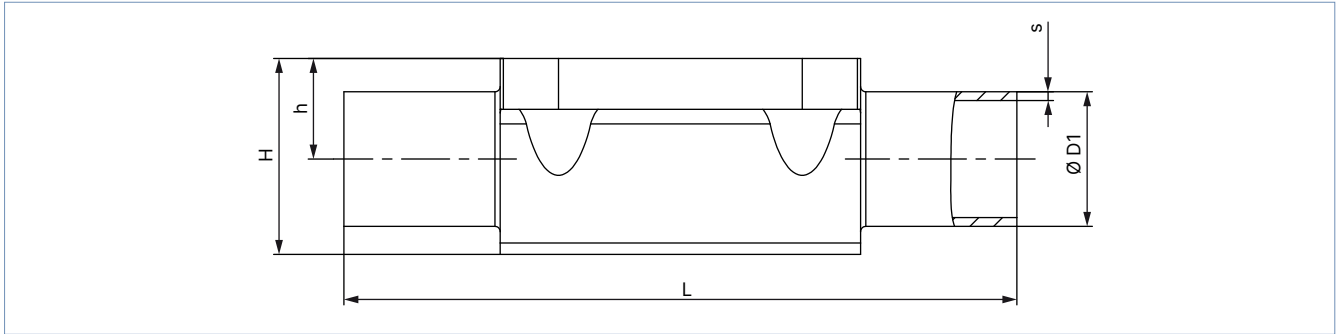

Diaphragm size	Port connection DN	Ø D1	s	L	h	H	Product key <sup>1)</sup>
<b>DIN EN ISO 1127 / ISO 4200 / DIN 11866 series B</b>							
8	8	13.5	1.6	90	9.3	18.8	SA40
15	8	13.5	1.6	108	8.15	19.85	SA40
8	10	17.2	1.6	90	9.3	18.8	SA41
15	10	17.2	1.6	110	12.05	23.75	SA41
15	15	21.3	1.6	110	12.05	23.75	SA42
20	15	21.3	1.6	119	16	30.3	SA42
20	20	26.9	1.6	119	16	30.3	SA43
25	20	26.9	1.6	119	19	37	SA43
25	25	33.7	2.0	129	19	37	SA44
40	25	33.7	2.0	161	27.6	52.4	SA44
40	32	42.4	2.0	161	27.6	52.4	SA45
40	40	48.3	2.0	161	27.6	52.4	SA46
50	50	60.3	2.0	192	35.5	68.3	SA47
80	65	76.1	2.0	250	51	98.1	SA48
80	80	88.9	2.3	250	51	98.1	SA49
100 <sup>2)</sup>	100	114.3	2.3	295	63.5	127.0	SA39
<b>DIN 11850 - 2 / DIN 11866 series A / DIN EN 10357 series A</b>							
8	10	13	1.5	90	9.3	18.8	SD40
15	10	13	1.5	110	8.15	19.85	SD40
15	15	19	1.5	110	12.05	23.75	SD42
20	20	23	1.5	119	16.0	30.3	SD43
25	25	29	1.5	129	19.0	37.0	SD44
40	32	35	1.5	161	27.6	52.4	SD45
40	40	41	1.5	161	27.6	52.4	SD46
50	50	53	1.5	192	35.5	68.3	SD47
80	65	70	2.0	250	51.0	98.1	SD48
80	80	85	2.0	250	51.0	98.1	SD49
100 <sup>2)</sup>	100	104	2	295	63.5	127.0	SD50

DTS 1000450617 EN Version: G Status: RL (released | freigegeben | validé) printed: 18.12.2024

Diaphragm size	Port connection DN	Ø D1	s	L	h	H	Product key <sup>1)</sup>
<b>ASME BPE / DIN 11866 series C</b>							
8	¼"	6.35	0.89	78	5.7	15.2	SA90
8	⅜"	9.53	0.89	89	5.7	15.2	SA91
8	½"	12.7	1.65	89	9.3	18.8	SA92
15	½"	12.7	1.65	108	8.15	19.85	SA92
15	¾"	19.05	1.65	108	12.05	23.75	SA93
20	¾"	19.05	1.65	117	16.0	30.3	SA93
25	1"	25.4	1.65	127	19.0	37.0	SODF
40	1½"	38.1	1.65	159	27.6	52.4	SODH
50	2"	50.8	1.65	190	35.5	68.3	SODI
50	2½"	63.5	1.65	192	35.5	68.6	SODJ
80	2½"	63.5	1.65	250	51.0	98.1	SODJ
80	3"	76.2	1.65	250	51.0	98.1	SODK
100 <sup>2)</sup>	4"	101.6	2.11	295	63.5	127.0	SODL
<b>BS 4825</b>							
8	8	6.35	1.20	78	5.7	15.2	SODB
8	10	9.53	1.20	89	5.7	15.2	SODC
15	15	12.7	1.20	108	8.15	19.85	SODD
20	20	19.05	1.20	117	16.0	30.3	SODE
25	25	25.4	1.65	127	19.0	37.0	SODF
40	40	38.1	1.65	159	27.6	52.4	SODH
50	50	50.8	1.65	190	35.5	68.3	SODI
50	65	63.5	1.65	192	35.5	68.6	SODJ
80	80	63.5	1.65	250	51.0	98.1	SODJ
80	80	76.2	1.65	250	51.0	98.1	SODK
<b>SMS 3008</b>							
25	25	25	1.2	129	19	37	SA60
40	40	38	1.2	161	27.6	52.4	SA62
50	50	51	1.2	192	35.5	68.3	SA63
100 <sup>2)</sup>	100	101.6	2	295	63.5	127.0	SA66
<b>DIN 11850 - 0</b>							
8	6	8	1.0	90	5.7	15.2	SC41
8	8	10	1.0	90	5.7	15.2	SC42

1.) This information is part of the product key (see "6.3. Bürkert Product Enquiry Form" on page 25).

2.) Only available as block material

### 4.3. Forged steel valve body (VS) with clamp connection

**Note:**

- Dimensions in mm, unless otherwise stated
- Further information on the draining angle can be found in the “Additional manual Type 2xxx 3xxx” on our website (see **operating instructions Type 3233** ▶).

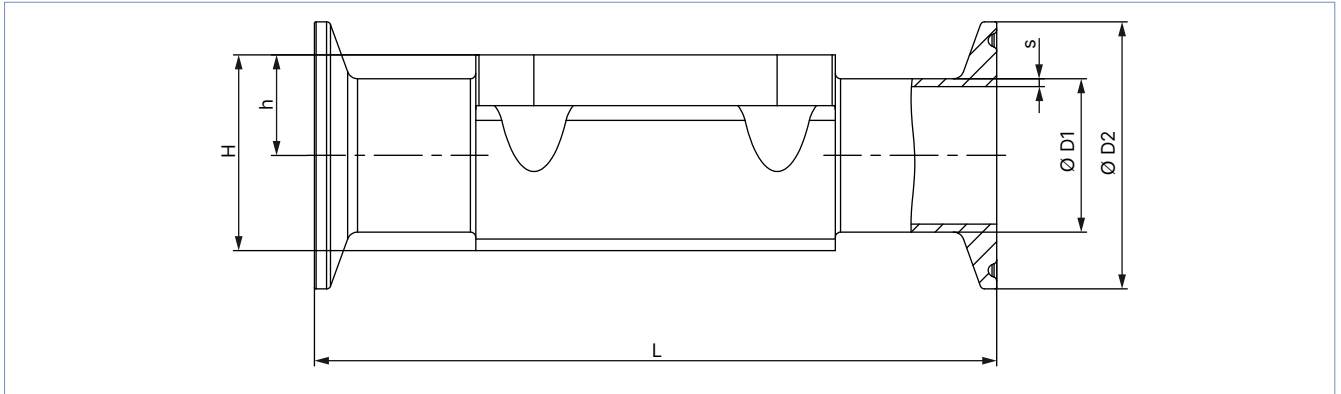

Diaphragm size	Port connection DN	Ø D1	s	Ø D2	L	h	H	Product key <sup>1)</sup>	Variable code <sup>1)</sup>
<b>DIN 32676 series B (ISO pipe)</b>									
15	15	21.3	1.6	50.5	167	12.05	23.75	TC52	–
20	20	26.9	1.6	50.5	114	16.0	30.3	TC43	–
25	25	33.7	2	50.5	129	19	37	TC44	–
40	40	48.3	2	64.0	161	27.6	52.4	TC46	–
50	50	60.3	2	77.5	190	35.5	68.3	TC47	–
65	65	76.1	2	91	190	35.5	63.3	TC48	–
80	80	88.9	2.3	106	222	51.0	98.1	TC49	–
100 <sup>2)</sup>	100	114.3	2.3	130	350	63.5	127.0	TC50	–
<b>DIN 32676 series A (DIN pipe)</b>									
8	10	13	1.5	34.0	126	9.3	18.8	TD41	–
15	10	13	1.5	34.0	110	8.15	19.85	TD41	–
15	15	19	1.5	34.0	110	12.05	23.75	TD42	–
20	20	23	1.5	34.0	119	16	30.3	TD43	–
25	25	29	1.5	50.5	129	19	37	TD44	–
40	40	41	1.5	50.5	161	27.6	52.4	TD46	–
50	50	53	1.5	64.0	192	35.5	68.3	TD47	–
65	65	70	2	91	248	43.0	83.5	TC48	–
80	80	70	2	91	222	51.0	98.1	TC49	–

DTS 1000450617 EN Version: G Status: RL (released | freigegeben | validé) printed: 18.12.2024

ASME BPE									
8	1/4"	6.35	0.89	25.0	64.5	5.7	15.2	TG50	–
8	3/8"	9.53	0.89	25.0	89	5.7	15.2	TG01	AF34
8	1/2"	12.7	1.65	25.0	64	9.3	18.8	TG02	–
8	1/2"	12.7	1.65	25.0	89	9.3	18.8	TG02	AF34
15	1/2"	12.7	1.65	25.0	89	8.15	19.85	TG02	–
15	1/2"	12.7	1.65	25.0	108	8.15	19.85	TG02	AF34
15	3/4"	19.05	1.65	25.0	89	12.05	23.75	TG03	–
20	3/4"	19.05	1.65	25.0	102	16	30.3	TG03	–
20	3/4"	19.05	1.65	25.0	117	16	30.3	TG03	AF34
25	1"	25.4	1.65	50.5	114	19	37	TG04	–
25	1"	25.4	1.65	50.5	127	19	37	TG04	AF34
40	1 1/2"	38.1	1.65	50.5	140	27.6	52.4	TG05	–
40	1 1/2"	38.1	1.65	50.5	159	27.6	52.4	TG05	AF34
50	2"	50.8	1.65	64.0	159	35.5	68.3	TG06	–
50	2"	50.8	1.65	64.0	190	35.5	68.3	TG06	AF34
65	2 1/2"	63.5	1.65	77.5	249	43	83.5	TG07	–
80	2 1/2"	63.5	1.65	77.5	216	51	98.1	TG07	–
80	3"	76.2	1.65	91.0	222	51	98.1	TG08	–
100 <sup>2.)</sup>	4"	101.6	2.11	119	306	63.5	127.0	TG09	–

1.) This information is part of the product key (see "6.3. Bürkert Product Enquiry Form" on page 25).

2.) Only available as block material

#### 4.4. Tube valve body (VP) with welded connection

**Note:**

- Dimensions in mm, unless otherwise stated
- Further information on the draining angle can be found in the “Additional manual Type 2xxx 3xxx” on our website (see **operating instructions Type 3233** ▶).

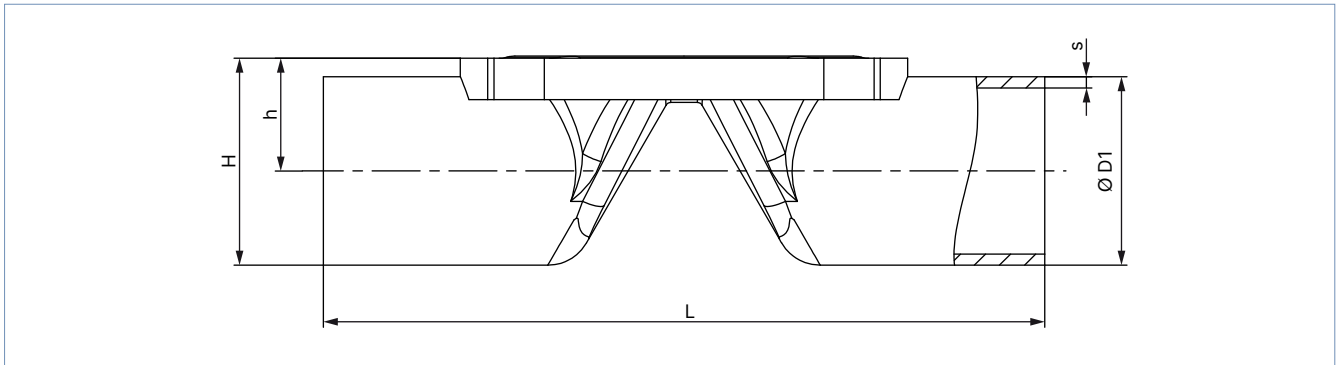

Diaphragm size	Port connection DN	Ø D1	s	L	h	H	Product key <sup>1)</sup>
<b>DIN EN ISO 1127 / ISO 4200 / DIN 11866 series B</b>							
8	8	13.5	1.6	90.0	9.85	16.6	SA40
8	10	17.2	1.6	90.0	11.70	20.3	SA41
15	15	21.3	1.6	110.0	14.35	25.0	SA42
20	20	26.9	1.6	119.0	17.15	30.45	SA43
25	25	33.7	2.0	129.0	20.55	37.4	SA44
32	32	42.4	2.0	148.0	25.10	46.3	SA45
40	40	48.3	2.0	161.0	29.35	53.5	SA46
50	50	60.3	2.0	192.0	35.35	65.50	SA47
<b>DIN 11850 - 2 / DIN 11866 series A / DIN EN 10357 series A</b>							
8	10	13	1.5	90	9.85	16.35	SD40
15	15	19	1.5	110	13.20	22.70	SD42
15	20	23	1.5	119	15.20	26.70	SD43
20	25	29	1.5	129	18.20	32.70	SD44
25	32	35	1.5	148	21.20	38.70	SD45
32	40	41	1.5	161	24.40	44.90	SD46
40	50	53	1.5	192	31.70	58.20	SD47
<b>ASME BPE / DIN 11866 series C</b>							
8	1/2"	12.7	1.65	90.0	9.45	21.95	SA92
15	3/4"	19.05	1.65	117.0	13.23	25.73	SA93
20	1"	25.4	1.65	127.0	16.40	41.65	SODF
32	1 1/2"	38.1	1.65	159.0	22.95	48.20	SODH
40	2"	50.8	1.65	190	30.60	62.60	SODI
50	2 1/2"	63.5	1.65	192	37.35	69.1	SODJ
65	3"	76.2	1.65	250	46.3	84.4	SODK
80	4"	101.6	2.11	295	60	110.8	SODL

1.) This information is part of the product key (see "6.3. Bürkert Product Enquiry Form" on page 25).

#### 4.5. Tube valve body (VP) with clamp connection

**Note:**

- Dimensions in mm, unless otherwise stated
- Further information on the draining angle can be found in the “Additional manual Type 2xxx 3xxx” on our website (see **operating instructions Type 3233** ▶).

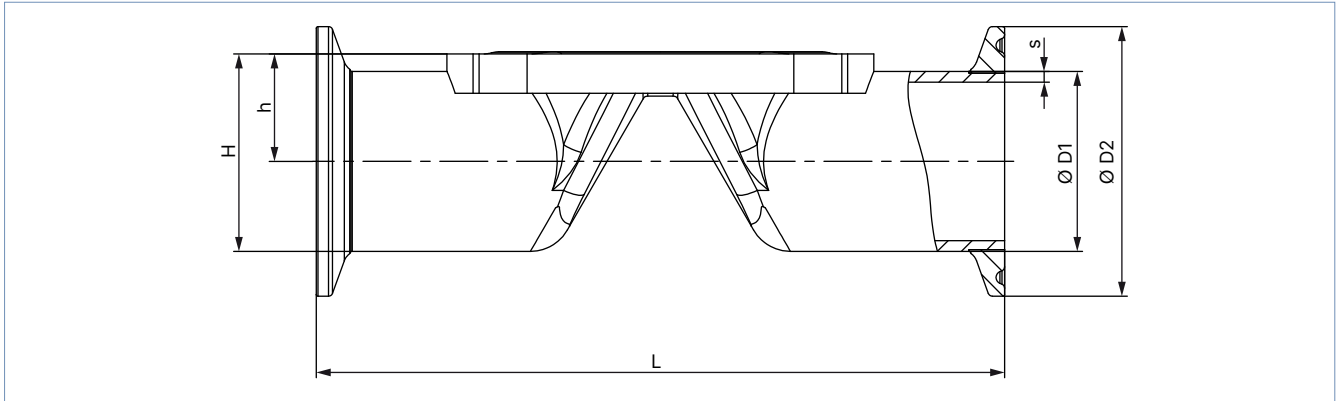

Diaphragm size	Port connection DN	Ø D1	s	Ø D2	L	h	H	Product key <sup>1)</sup>
<b>DIN 32676 series B (ISO pipe)</b>								
8	8	13.5	1.6	25.0	89	9.85	22.35	TC40
8	10	17.2	1.6	25.0	89	11.70	24.20	TC53
15	15	21.3	1.6	50.5	110	14.35	39.60	TC52
20	20	26.9	1.6	50.5	119	17.15	42.40	TC43
25	25	33.7	2.0	50.5	129	20.55	45.80	TC44
32	32	42.4	2.0	64.0	148	25.10	57.10	TC55
40	40	48.3	2.0	64.0	161	29.35	61.35	TC46
50	50	60.3	2.0	77.5	192	35.35	74.10	TC47
<b>DIN 32676 series A (DIN pipe)</b>								
8	10	13.0	1.5	34.0	89	9.85	26.85	TD41
15	15	19.0	1.5	34.0	110	13.2	30.20	TD42
15	20	23.0	1.5	34.0	119	15.20	32.20	TD43
20	25	29.0	1.5	50.5	129	18.20	43.45	TD44
25	32	35.0	1.5	50.5	148	21.20	46.45	TD45
32	40	41.0	1.5	50.5	161	24.40	49.65	TD46
40	50	53.0	1.5	64.0	192	31.70	63.70	TD47
<b>ASME BPE</b>								
8	½"	12.7	1.65	25.0	89	9.45	21.95	TG02
15	¾"	19.05	1.65	25.0	102	13.20	25.73	TG03
20	1"	25.4	1.65	50.5	114	16.40	41.65	TG04
32	1½"	38.10	1.65	50.5	140	22.95	48.20	TG05
40	2"	50.80	1.65	64.0	159	30.60	62.60	TG06
50	2½"	63.5	1.65	77.5	190	37.35	69.1	TG07

1.) This information is part of the product key (see "6.3. Bürkert Product Enquiry Form" on page 25).

#### 4.6. Tube valve body (VP) with threaded connection

**Note:**

- Dimensions in mm, unless otherwise stated
- Further information on the draining angle can be found in the “Additional manual Type 2xxx 3xxx” on our website (see **operating instructions Type 3233** ▶).

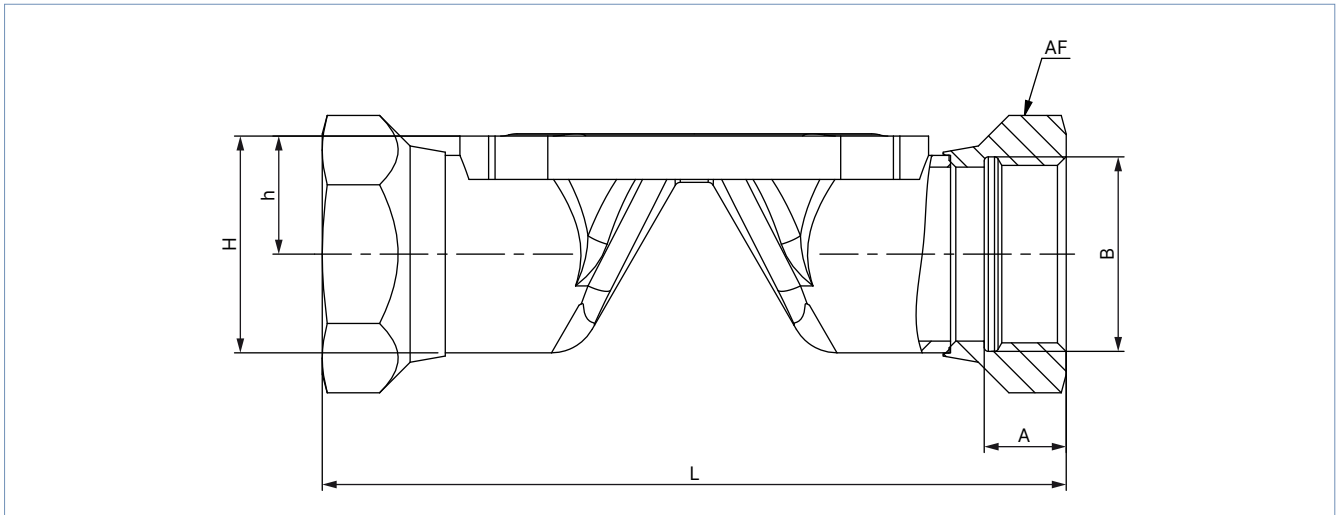

Diaphragm size	L	A	B	h	H	Width across flats of threaded ports	Product key <sup>1)</sup>
08	85	9	G ¼	11.70	20.3	17	GM82
15	102	14	G ½	14.35	25.0	27	GM84
20	118	12	G ¾	17.15	30.45	32	GM85
25	127	14	G 1	20.55	37.4	41	GM86
32	146	16	G 1¼	25.10	46.3	50	GM87
40	159	18	G 1½	29.35	53.5	60	GM88
50	191	20	G 2	35.35	65.50	70	GM89
Diaphragm size	L	A	B	h	H	Width across flats of threaded ports	Product key <sup>1)</sup>
08	85	9.7	Rc ¼	11.70	20.3	17	RC82
15	102	13.2	Rc ½	14.35	25.0	27	RC84
20	118	14.5	Rc ¾	17.15	30.45	32	RC85
25	127	16.8	Rc 1	20.55	37.4	41	RC86
32	146	19.1	Rc 1¼	25.10	46.3	50	RC87
40	159	19.1	Rc 1½	29.35	53.5	60	RC88
50	191	23.4	Rc 2	35.35	65.50	70	RC89
Diaphragm size	L	A	B	h	H	Width across flats of threaded ports	Product key <sup>1)</sup>
08	85	10	NPT ¼	11.70	20.3	17	NM82
15	102	13.7	NPT ½	14.35	25.0	27	NM84
20	118	14	NPT ¾	17.15	30.45	32	NM85
25	127	16.8	NPT 1	20.55	37.4	41	NM86
32	146	17.3	NPT 1¼	25.10	46.3	50	NM87
40	159	17.3	NPT 1½	29.35	53.5	60	NM88
50	191	17.6	NPT 2	35.35	65.50	70	NM89

1.) This information is part of the product key (see “6.3. Bürkert Product Enquiry Form” on page 25).

#### 4.7. Tube valve body (VP) with flange connection

**Note:**

- Dimensions in mm, unless otherwise stated
- Further information on the draining angle can be found in the “Additional manual Type 2xxx 3xxx” on our website (see **operating instructions Type 3233** ▶).

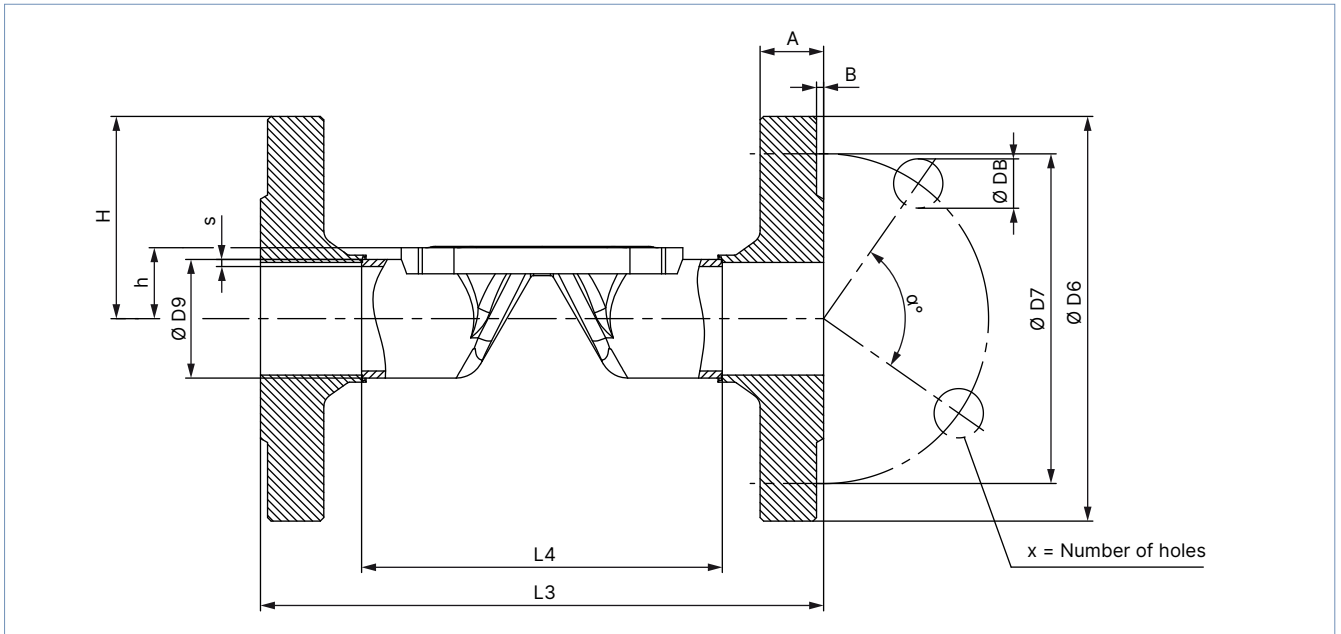

Diaphragm size	L4	L3	s3	ØD9	ØD6	ØD7	a°	ØDB	A	B	X	Product key <sup>1)</sup>
<b>DIN EN 1092 - 1</b>												
15	76.5	130	1.6	21.3	76.5	65.0	90	14	16	2	4	FD22
20	92.5	150	1.6	26.9	92.5	75.0	90	14	18	2	4	FD23
25	102.5	160	2.0	33.7	102.5	85.0	90	14	18	2	4	FD24
32	122.5	180	2.0	42.4	122.5	100.0	90	18	18	2	4	FD25
40	136.5	200	2.0	48.3	136.5	110.0	90	18	18	3	4	FD26
50	160.5	230	2.0	60.3	160.5	125.0	90	18	20	3	4	FD27
<b>ANSI B16.5</b>												
15	67.0	130	1.6	21.3	89	60.5	90	15.7	11.2	1.6	4	FA02
25	106.0	160	2.0	33.7	108	79.2	90	15.7	14.2	1.6	4	FA04
40	128.0	200	2.0	48.3	127	98.6	90	15.7	17.5	1.6	4	FA06
50	151.0	230	2.0	60.3	152	120.7	90	19.1	19.1	1.6	4	FA07
<b>JIS 10K</b>												
15	89	130	1.6	21.3	95	70	90	15	12	1	4	FJ01
20	103	150	1.6	26.9	100	75	90	15	14	1	4	FJ02
25	116	160	2.0	33.7	125	90	90	19	14	1	4	FJ03
40	147	200	2.0	48.3	140	105	90	19	16	2	4	FJ05
50	175	230	2.0	60.3	155	120	90	19	16	2	4	FJ06

1.) This information is part of the product key (see “6.3. Bürkert Product Enquiry Form” on page 25).

#### 4.8. Cast valve body (VG) with welded connection

**Note:**

- Dimensions in mm, unless otherwise stated
- Further information on the draining angle can be found in the “Additional manual Type 2xxx 3xxx” on our website (see **operating instructions Type 3233** ▶).

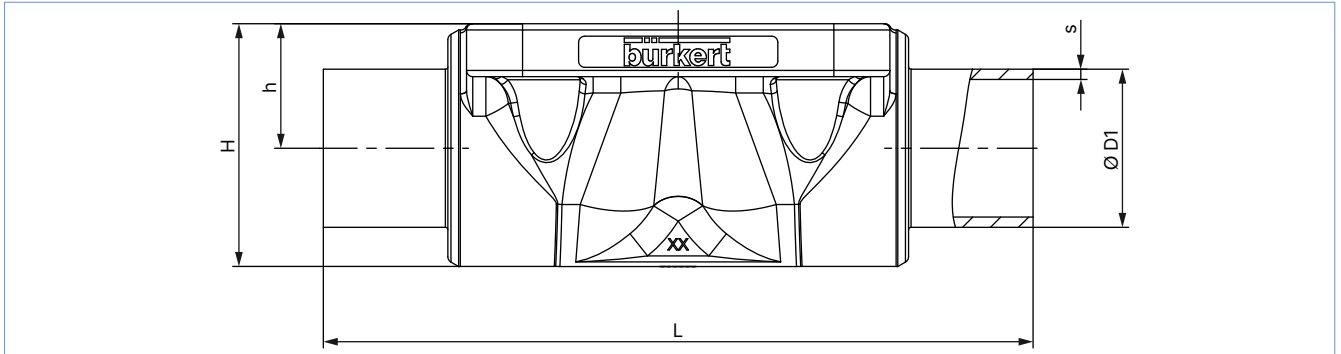

Diaphragm size	Port connection DN	Ø D1	s	L	h	H	Product key <sup>1)</sup>
<b>DIN EN ISO 1127 / ISO 4200 / DIN 11866 series B</b>							
8	8	13.5	1.6	90	9.6	18.5	SA40
8	10	17.2	1.6	90	9.6	18.6	SA41
15	15	21.3	1.6	110	13.5	25.0	SA42
20	15	21.3	1.6	119	18.0	32.9	SA42
20	20	26.9	1.6	119	18.0	32.7	SA43
25	25	33.7	2.0	129	20.0	39.0	SA44
40	32	42.4	2.0	161	28.6	55.0	SA45
40	40	48.3	2.0	161	28.6	55.0	SA46
50	50	60.3	2.0	192	35.5	68.0	SA47
65	65	76.1	2.0	192	43.0	82.0	SA48
80	80	76.1	2.0	250	51.0	101.0	SA48
80	80	88.9	2.3	250	51.0	101.0	SA49
100	100	114.3	2.3	295	63.5	123.5	SA39
<b>DIN 11850 - 2 / DIN 11866 series A / DIN EN 10357 series A</b>							
8	10	13	1.5	90	9.6	18.6	SD40
15	15	19	1.5	110	13.5	25.0	SD42
20	20	23	1.5	119	18.0	32.8	SD43
25	25	29	1.5	129	20.0	39.0	SD44
40	40	41	1.5	161	28.6	55.0	SD46
50	50	53	1.5	192	35.5	68.0	SD47
65	65	70	2.0	192	43.0	82.0	SD48
80	80	85	2.0	250	51.0	101.0	SD49
100	100	104	2.0	295	63.5	123.5	SD50
<b>ASME BPE / DIN 11866 series C</b>							
8	¼"	6.35	0.89	64.5	9.6	18.6	SA90
8	⅜"	9.53	0.89	89	9.6	18.6	SA91
8	½"	12.7	1.65	89	9.6	18.6	SA92
15	¾"	19.05	1.65	102	13.5	25.0	SA93
20	¾"	19.05	1.65	119	18.0	32.8	SA93
20	1"	25.4	1.65	119	18.0	32.7	SODF
25	1"	25.4	1.65	114	20.0	39.0	SODF
40	1½"	38.1	1.65	140	28.6	55.0	SODH
50	2"	50.8	1.65	159	35.5	68.0	SODI
50	2½"	63.5	1.65	192	35.5	68.0	SODJ
65	2½"	63.5	1.65	192	43.0	82.0	SODJ
80	3"	76.2	1.65	250	51.0	101.0	SODK
100	4"	101.6	2.11	295	63.5	123.5	SODL

DTS 1000450617 EN Version: G Status: RL (released | freigegeben | validé) printed: 18.12.2024

Diaphragm size	Port connection DN	ØD1	s	L	h	H	Product key <sup>1)</sup>
<b>BS 4825</b>							
8	8	6.35	1.20	64.5	9.6	18.6	SODB
8	10	9.53	1.20	89	9.6	18.6	SODC
8	15	12.7	1.20	89	9.6	18.6	SODD
15	20	19.05	1.20	102	14.0	25.5	SODE
20	25	25.4	1.65	119	18.0	32.8	SODF
25	25	25.4	1.65	114	20.0	39.0	SODF
40	40	38.1	1.65	140	28.6	55.0	SODH
50	50	50.8	1.65	159	35.5	68.0	SODI
50	65	63.5	1.65	192	35.5	68.0	SODJ
65	65	63.5	1.65	192	43.0	82.0	SODJ
80	80	76.2	1.65	250	51.0	101.0	SODK
100	100	101.6	2.11	295	63.5	123.5	SODL
<b>SMS 3008</b>							
20	25	25	1.2	119	18.0	32.8	SA60
25	25	25	1.2	129	20.0	39.0	SA60
40	40	38	1.2	161	28.6	55.0	SA62
50	50	51	1.2	192	35.5	68.0	SA63
<b>DIN 11850 - 0</b>							
8	4	6	1.0	90	9.6	18.6	SC40
8	6	8	1.0	90	9.6	18.6	SC41
8	8	10	1.0	90	9.6	18.6	SC42
15	15	18	1.5	110	13.5	25.0	SC43
20	20	22	1.5	119	18.0	32.8	SC44
25	25	28	1.5	129	20.0	39.0	SC45
25	32	34	1.5	129	20.0	39.0	SC46
40	40	40	1.5	161	28.6	56.0	SC47
50	50	52	1.5	192	35.5	68.0	SC48

1.) This information is part of the product key (see "6.3. Bürkert Product Enquiry Form" on page 25).

#### 4.9. Cast valve body (VG) with clamp connection

**Note:**

- Dimensions in mm, unless otherwise stated
- Further information on the draining angle can be found in the “Additional manual Type 2xxx 3xxx” on our website (see **operating instructions Type 3233** ▶).

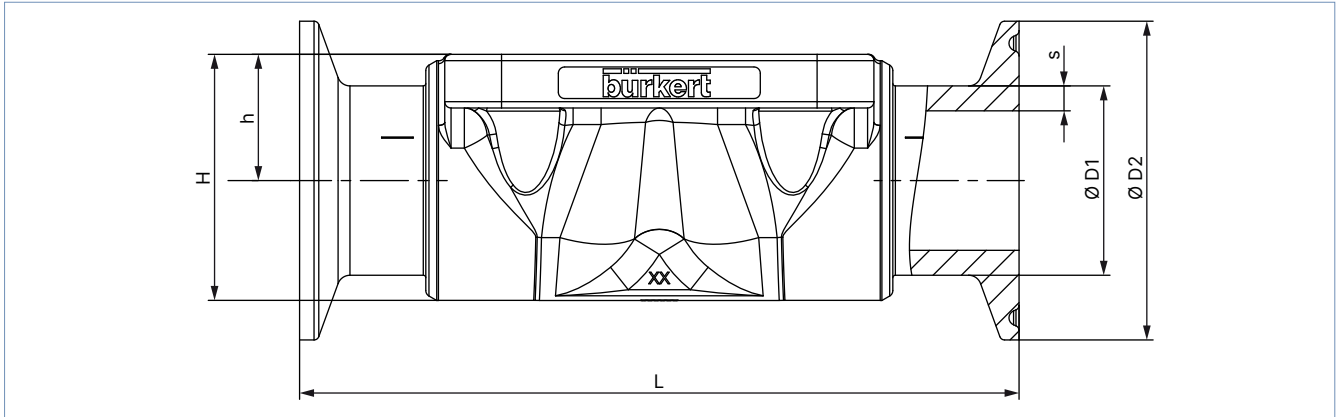

Diaphragm size	Port connection DN	ØD1	s	ØD2	L	h	H	Product key <sup>1)</sup>
<b>DIN 32676 series B (ISO pipe)</b>								
25	25	33.7	2	50.5	129	20.0	39.0	TC44
40	40	48.3	2	64.0	161	28.6	55.0	TC46
50	50	60.3	2	77.5	192	35.5	68.0	TC47
<b>DIN 32676 series A (DIN pipe)</b>								
15	15	19	1.5	34.0	110	13.5	25.0	TD42
20	20	23	1.5	34.0	119	18.0	32.8	TD43
25	25	29	1.5	50.5	129	20.0	39.0	TD44
40	40	41	1.5	50.5	161	28.6	55.0	TD46
50	50	53	1.5	64.0	192	35.5	68.0	TD47
<b>ASME BPE</b>								
8	3/8"	9.53	0.89	25.0	89	9.6	18.6	TG01
8	1/2"	12.7	1.65	25.0	89	9.6	18.6	TG02
15	3/4"	19.05	1.65	25.0	102	13.5	23.0	TG03
20	3/4"	19.05	1.65	25.0	117	18.0	25.0	TG03
25	1"	25.4	1.65	50.5	114	18.0	40.0	TG04
40	1 1/2"	38.1	1.65	50.5	140	28.6	55.0	TG05
50	2"	50.8	1.65	64.0	159	35.5	68.0	TG06
50	2 1/2"	63.5	1.65	77.5	190	35.5	68.0	TG07
65	2 1/2"	63.5	1.65	77.5	249.2	43.0	82.0	TG07
80	3"	76.2	1.65	91	306.2	51.0	101.0	TG08
100	4"	101.6	2.11	119	352.2	63.5	123.5	TG09
<b>BS 4825: Clamp BS 4825 - 3 / pipe BS 4825 - 1</b>								
8	15	12.7	1.2	25	89	9.6	18.9	TH42
15	20	19.05	1.2	25	102	13.5	25.0	TH43
25	25	25.4	1.65	50.5	114	20.0	39.0	TG04
40	40	38.1	1.65	50.5	140	28.6	55.0	TG05
50	50	50.8	1.65	64.0	159	35.5	68.0	TG06
50	65	63.5	1.65	77.5	190	35.5	68.0	TG07
<b>Clamp 34.0 similar to DIN 32676 series B (ISO pipe)</b>								
15	15	21.3	1.6	34	110	13.5	25.0	TC42

1.) This information is part of the product key (see “6.3. Bürkert Product Enquiry Form” on page 25).

#### 4.10. Plastic body (PV, PD, PP) with spigot connection

**Note:**

Dimensions in mm, unless otherwise stated

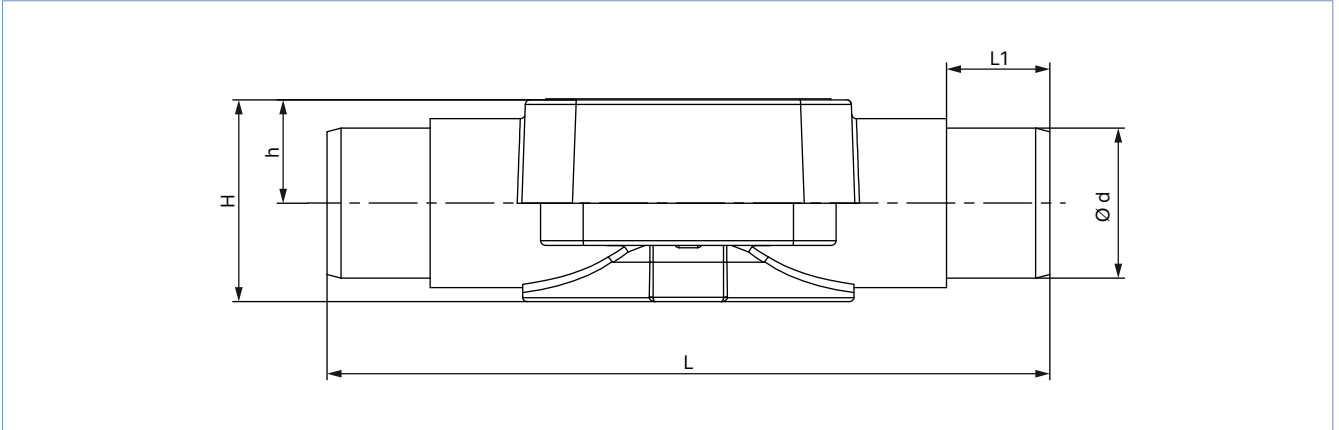

Diaphragm size	Ø d	Wall thickness	h	H	L	L1	Product key <sup>1.)</sup>
<b>PVC-U (PV)</b>							
15	20	2.5	15	29	124	16	KS25
20	25	2.5	18.5	36	144	19	KS26
25	32	3.5	22	43	154	22	KS27
32	40	4	27	52.5	174	26	KS28
40	50	5	33	65.5	194	31	KS29
50	63	6.5	40	79	224	44	KS30
<b>PVDF (PD) and PP (PP)</b>							
15	20	2.5	15	29	124	16	SS25
20	25	2.5	18.5	36	144	19	SS26
25	32	3.5	22	43	154	22	SS27
32	40	4	27	52.5	174	26	SS28
40	50	5	33	65.5	194	31	SS29
50	63	6.5	40	79	224	44	SS30

1.) This information is part of the product key (see "6.3. Bürkert Product Enquiry Form" on page 25).

**4.11. Plastic body (PV, PD, PP) with true union**

**Note:**

Dimensions in mm, unless otherwise stated

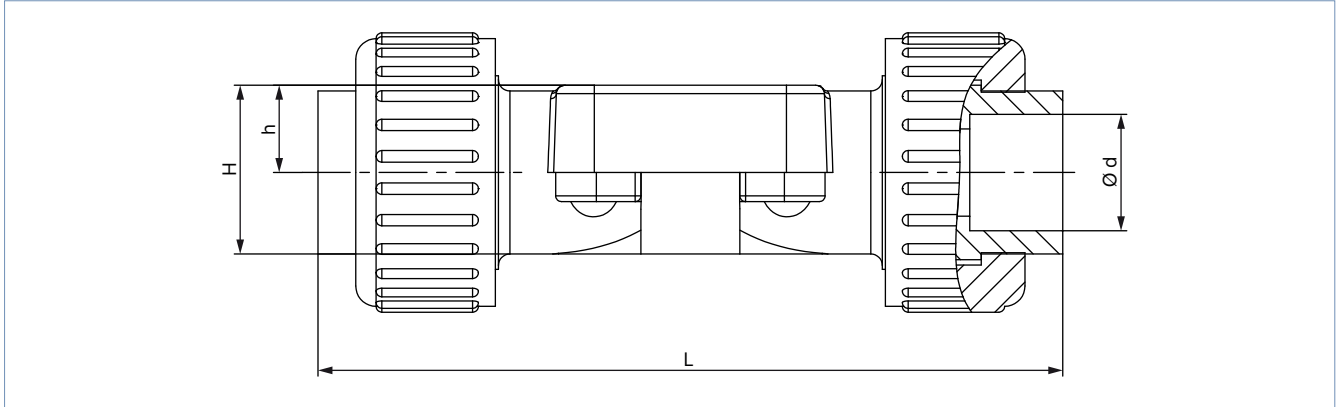

Diaphragm size	L	h	H	Ød	Product key <sup>1)</sup>
<b>PVC-U (PV)</b>					
15	128	15	29	20	KM25
20	152	18.5	36	25	KM26
25	166	22	43	32	KM27
32	192	27	52.5	40	KM28
40	222	33	65.5	50	KM29
50	266	40	79	63	KM30
<b>PVDF (PD)</b>					
15	129	15	29	20	SM25
20	150	18.5	36	25	SM26
25	162	22	43	32	SM27
32	184	27	52.5	40	SM28
40	210	33	65.5	50	SM29
50	248	40	79	63	SM30
<b>PP (PP)</b>					
15	125	15	29	20	SM25
20	146	18.5	36	25	SM26
25	158	22	43	32	SM27
32	181	27	52.5	40	SM28
40	207	33	65.5	50	SM29
50	245	40	79	63	SM30

1.) This information is part of the product key (see "6.3. Bürkert Product Enquiry Form" on page 25).

**4.12. Plastic body (PV, PD, PP) with flange connection**

**Note:**

Dimensions in mm, unless otherwise stated

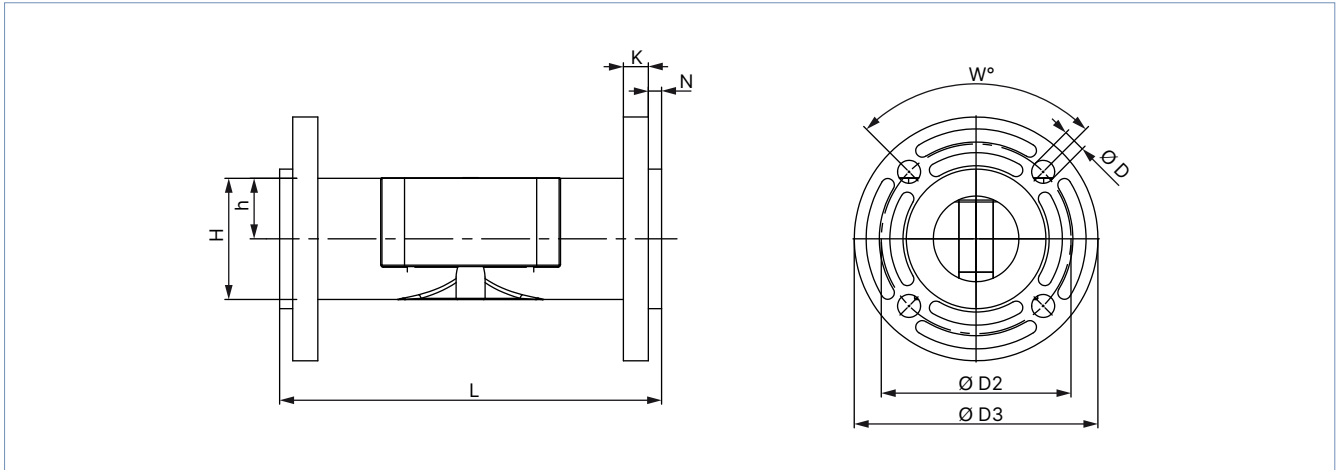

Diaphragm size	L	ØD2	ØD3	K	H	h	ØD	W	N (only for DN 65)	Product key <sup>1.)</sup>
<b>PVC-U (PV), PVDF (PD) and PP (PP)</b>										
15	130	65.5	96	12	-	-	14	4×90°	5.9	FL24
20	150	75	105	14	-	-	14	4×90°	6.9	FL25
25	160	85	115	15	-	-	14	4×90°	6.9	FL26
32	180	100	140	17	-	-	18	4×90°	7.9	FL27
40	200	110	150	17	-	-	18	4×90°	8	FL28
50	230	125	165	18	-	-	18	4×90°	9	FL29
65	290	145	185	19	92	47	18	4×90°	10	FL30
80	310	160	200	36	107	50	18	8×45°	-	FF31
100	350	180	225	35	134.5	65.5	18	8×45°	-	FF32

1.) This information is part of the product key (see "6.3. Bürkert Product Enquiry Form" on page 25).

## 5. Performance specifications

### 5.1. Flow characteristics

#### Note:

- The  $K_v$  values may vary slightly with different actuator sizes and diaphragm materials.
- Further  $K_v$  values are available on request.
- Flow rate:  $K_v$  value water (m<sup>3</sup>/h) for elastomer diaphragms
- Measurement at + 20 °C, 4 bar at valve inlet and 3 bar at valve outlet

#### Forged steel valve body (VS)

Diaphragm size	Port connection		$K_v$ value [m <sup>3</sup> /h]					
			DIN EN ISO 1127 ISO 4200 DIN 11866 series B	DIN 11850 - 2 DIN 11866 series A DIN EN 10357 series A	ASME BPE DIN 11866 series C	DIN 11850 - 0	BS4825	SMS3008
DN	[mm]	[inch]	[m <sup>3</sup> /h]	[m <sup>3</sup> /h]	[m <sup>3</sup> /h]	[m <sup>3</sup> /h]	[m <sup>3</sup> /h]	[m <sup>3</sup> /h]
8	6	1/8"	–	–	–	1.1	–	–
8	8	1/4"	1.5	–	0.7	1.7	0.5	–
8	10	3/8"	1.5	1.5	1.6	–	1.4	–
8	15	1/2"	–	–	1.5	–	–	–
15	10	3/8"	5.5	3.5	–	–	–	–
15	15	1/2"	6.5	6.5	3.1	–	3.7	–
15	20	3/4"	–	–	6.5	–	–	–
20	20	3/4"	12.5	12.4	8.4	–	8.9	–
25	25	1"	18	20	15.5	–	15.5	16
40	32	1 1/4"	–	34	–	–	–	–
40	40	1 1/2"	41	40	37	–	37	38
50	50	2"	66	66	66	–	66	66
50	65	2 1/2"	–	–	66	–	66	66
65	65	2 1/2"	110	–	110	–	–	–
80	80	3"	160	160	160	–	–	–
100	100	4"	235	235	235	–	–	–

#### Tube valve body (VP)

Diaphragm size	Port connection		$K_v$ value [m <sup>3</sup> /h]		
			DIN EN ISO 1127 ISO 4200 DIN 11866 series B	DIN 11850 - 2 DIN 11866 series A DIN EN 10357 series A	ASME BPE DIN 11866 series C
DN	[mm]	[inch]	[m <sup>3</sup> /h]	[m <sup>3</sup> /h]	[m <sup>3</sup> /h]
8	8	1/4"	1.9	–	–
8	10	3/8"	–	1.9	–
8	15	1/2"	–	–	1.8
15	10	3/8"	–	–	7.1
15	15	1/2"	7.2	7.4	–
15	20	3/4"	–	7.4	–
20	20	3/4"	13.5	–	–
20	25	1"	–	14.9	12.8
25	32	1 1/4"	–	22.3	–
25	25	1"	20.8	–	–
32	40	1 1/2"	–	34.8	31
40	40	1 1/2"	47.9	–	–
40	50	2"	–	46.2	43
50	50	2"	69.7	–	–
65	80	3"	–	–	75
80	100	4"	–	–	145

**Cast valve body (VG)**

Diaphragm size DN	Port connection		K <sub>v</sub> value water [m <sup>3</sup> /h]
	[mm]	[inch]	
8	8	1/4"	1
15	15	1/2"	5.6
20	20	3/4"	10.7
25	25	1"	14.6
40	40	1 1/2"	35
50	50	2"	47
65	65	2 1/2"	110
80	80	3"	130
100	100	4"	150

**Plastic body (PV, PD, PP)**

Diaphragm size DN	Port connection		K <sub>v</sub> value water [m <sup>3</sup> /h]
	[mm]	[inch]	
15	15	1/2"	3
20	20	3/4"	7
25	25	1"	11.4
32	32	1 1/4"	17
40	40	1 1/2"	24.5
50	50	2"	41.5
65	65	2 1/2"	60
80	80	3"	105
100	100	4"	154

**5.2. Medium pressure**

Diaphragm size DN	Actuator material	Maximum operating pressure for seal material
		EPDM, PTFE/EPDM, advanced PTFE/EPDM, laminated GYLON®/EPDM [bar]
8...80	Stainless steel/stainless steel	10
100	Stainless steel/stainless steel	6
8...50	Stainless steel/PPS	10
8...40	PPS/PPS	10
50	PPS/PPS	7

DTS 1000450617 EN Version: G Status: RL (released | freigegeben | validé) printed: 18.12.2024

## 6. Ordering information

### 6.1. Bürkert eShop



#### Bürkert eShop – Easy ordering and quick delivery

You want to find your desired Bürkert product or spare part quickly and order directly? Our online shop is available for you 24/7. Sign up and enjoy all the benefits.

[Order online now](#)

### 6.2. Bürkert product filter



#### Bürkert product filter – Get quickly to the right product

You want to select products comfortably based on your technical requirements? Use the Bürkert product filter and find suitable articles for your application quickly and easily.

[Try out our product filter](#)

### 6.3. Bürkert Product Enquiry Form

**Note:**

Please see our Product Enquiry Form for a full explanation of our specification key.

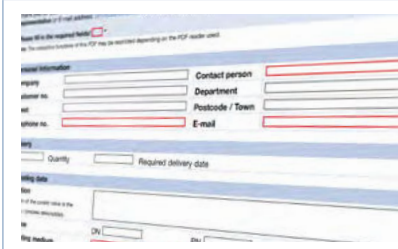

#### Bürkert Product Enquiry Form – Your enquiry quickly and compactly

Would you like to make a specific product enquiry based on your technical requirements? Use our Product Enquiry Form for this purpose. There you will find all the relevant information for your Bürkert contact. This will enable us to provide you with the best possible advice.

[Fill out the form now](#)

DTS 1000450617 EN Version: G Status: RL (released | freigegeben | valide) printed: 18.12.2024