



### Tank bottom diaphragm valve with pneumatic plastic actuator (Type CLASSIC)

- Valve body and diaphragm are available in various materials and variants
- Wetted surfaces from  $Ra \leq 0.38 \mu m \dots \leq 1.6 \mu m$  (optionally electropolished)
- Available in all common connection sizes and variants

Product variants described in the data sheet may differ from the product presentation and description.

#### Can be combined with

	<b>Type SV02</b> Diaphragms	▶
	<b>Type 2034</b> Multifunction bloc solutions	▶
	<b>Type 2933</b> 2/2-way diaphragm valve with manually operated actuator (basic)	▶
	<b>Type 2036</b> Robolux multiway diaphragm valve, pneumatically operated	▶
	<b>Type 8690</b> Pneumatic control unit for decentralised automation of process valves ELEMENT	▶
	<b>Type 8697</b> Pneumatic control unit for decentralised automation of process valves ELEMENT	▶
	<b>Type 8098</b> FLOWave SAW flowmeter	▶

#### Type description

The externally controlled diaphragm valve Type 2033 consists of a pneumatically operated piston actuator, a diaphragm and a tank bottom valve body. The proven and robust actuator with a plastic housing ensures use in hygienic or aggressive ambient conditions. The flow-efficient valve bodies with little dead space enable high flow rates and a wide range of possible uses. The valve body and the diaphragm are available in all common materials and variants. The actuator has a compact, autoclavable design (PPS variant). The integration of the automation units Type 8690/8697 is possible in all configuration levels (can be retrofitted). An explosion-proof ATEX/IECEx device variant is available.

The add-on body is optionally available in plastic or stainless steel. The actuator is equipped with an integrated, optical position indicator as standard, optionally a minimum/maximum stroke limiter can be installed.

DTS 1000450595 EN Version: L Status: RL (released | freigegeben | valide) printed: 09.09.2025

## Table of contents

<b>1. General technical data</b>	<b>3</b>
<b>2. Control functions</b>	<b>4</b>
<b>3. Approvals and conformities</b>	<b>5</b>
3.1. General notes .....	5
3.2. Conformity .....	5
3.3. Standards .....	5
3.4. Explosion protection.....	5
3.5. Foods and beverages/Hygiene .....	5
3.6. Others .....	6
<b>4. Materials</b>	<b>6</b>
4.1. Bürkert resistApp .....	6
4.2. Material specifications .....	6
4.3. Example of available membrane materials.....	7
<b>5. Dimensions</b>	<b>8</b>
5.1. Actuator .....	8
CLASSIC actuator with interface for block mounting (MT85).....	8
CLASSIC actuator with tank bottom body.....	9
5.2. Tank bottom body with welded connection .....	11
5.3. Tank bottom body with clamp connection .....	12
<b>6. Performance specifications</b>	<b>13</b>
6.1. Medium pressure .....	13
Information for control function A.....	13
<b>7. Product accessories</b>	<b>13</b>
<b>8. Networking and combination with other Bürkert products</b>	<b>14</b>
<b>9. Ordering information</b>	<b>15</b>
9.1. Bürkert eShop .....	15
9.2. Bürkert product filter .....	15
9.3. Bürkert Product Enquiry Form .....	15

DTS 1000450595 EN Version: L Status: RL (released | freigegeben | valide) printed: 09.09.2025

## 1. General technical data

Product properties	
Dimensions	Further information can be found in chapter "5. Dimensions" on page 8.
<b>Material</b>	
Block body (VH) <sup>1)</sup>	Stainless steel block material 1.4435 according to DIN EN 10088 and 316L according to ASTM A479 / A479M
Block body (VI) <sup>1)</sup>	Stainless steel block material 1.4435 according to BN2 and 316L according to ASME BPE Table DT- 3
Diaphragm	EPDM (AD) <sup>1)</sup> , PTFE/EPDM (EA) <sup>1)</sup> , Advanced PTFE/EPDM (EU) <sup>1)</sup> , laminate of GYLON® and EPDM (ER) <sup>1)</sup>
Actuator	PPS, PA
Diaphragm size	8...100
<b>Standard surface quality</b>	
Block body (VH/VI) <sup>1)</sup>	Internally electrically polished: Ra ≤ 0.38 µm (NO17) <sup>1)</sup> (ASME BPE SF4 / DIN HE4) (externally Ra ≤ 1.6 µm) Internally mechanically polished: Ra ≤ 0.5 µm (NO14) <sup>1)</sup> (ASME BPE SF1) (externally Ra ≤ 1.6 µm)
<b>Performance data</b>	
Maximum pilot pressure (CF A)	7 bar (for actuator size 40 <sup>1)</sup> ...125 <sup>1)</sup> /PPS) 6 bar (for actuator size 175 <sup>1)</sup> and 225 <sup>1)</sup> /PA) See "6.1. Medium pressure" on page 13
Pilot air port	Thread G ¼, thread G ⅝ for actuator size 40 and 50
<b>Medium data</b>	
Operating medium	Neutral gases and liquids, highly purified, sterile, aggressive or abrasive mediums (see <b>resistance chart</b> ▶)
<b>Medium temperature</b>	
EPDM (AD) <sup>1)</sup>	-10...+143 °C (steam sterilisation +150 °C for 60 min)
PTFE/EPDM (EA) <sup>1)</sup>	-10...+130 °C (steam sterilisation +140 °C for 60 min)
Advanced PTFE/EPDM (EU) <sup>1)</sup>	-5...+143 °C (steam sterilisation +150 °C for 60 min)
Laminate of GYLON® and EPDM (ER) <sup>1)</sup>	-5...+130 °C (steam sterilisation +140 °C for 60 min)
Control medium	Neutral gases, air
<b>Product connections</b>	
<b>Port connection</b> <sup>2)</sup>	
Nominal diameter	DN 06...DN 100 (¼"...4")
<b>Stainless steel body</b> <sup>2)</sup>	
Welded connection <sup>2)</sup>	DIN EN ISO 1127 / ISO 4200 / DIN 11866 series B DIN 11850 - 2 / DIN 11866 series A / DIN EN 10357 series A ASME BPE / DIN 11866 series C
Clamp connection <sup>2)</sup>	DIN 32676 series A (DIN pipe) DIN 32676 series B (ISO pipe) ASME BPE
<b>Environment and installation</b>	
Installation position	See <b>operating manual Type 2033</b> ▶
<b>Ambient temperature</b>	
PPS, actuator size ≤ 80 mm	+5...+140 °C
PPS, actuator size 100 mm, 125 mm	+5...+90 °C (short-term up to +140 °C)
PA, actuator size ≤ 125 mm	-10...+60 °C
PA, actuator size ≥ 175 mm	-10...+50 °C

1.) This information is part of the product key (see "9.3. Bürkert Product Enquiry Form" on page 15).

2.) Other variants are available on request.

## 2. Control functions

Symbol	Description
	<p><b>Control function A (CF A)</b>                      Pneumatically operated tank bottom valve                      Normally closed by spring force</p>
	<p><b>Control function B (CF B)</b>                      Pneumatically operated tank bottom valve                      Normally opened by spring force</p>
	<p><b>Control function I (CF I)</b>                      Pneumatically operated tank bottom valve on either side                      Switching position dependent on external control</p>

### 3. Approvals and conformities

#### 3.1. General notes

- The approvals and conformities listed below must be stated when making enquiries. This is the only way to ensure that the product complies with all required specifications.
- Not all available variants can be supplied with the below mentioned approvals or conformities.



#### 3.2. Conformity

In accordance with the Declaration of Conformity, the product is compliant with the EU Directives.



#### 3.3. Standards

The applied standards which are used to demonstrate compliance with the EU Directives are listed in the EU-Type Examination Certificate and/or the EU Declaration of Conformity.

#### 3.4. Explosion protection

Approval	Description																
 	<p><b>Optional: Explosion protection (valid for the variable code PX51)</b> As a category 2 device suitable for zone 1/21 and zone 2/22.</p> <p><b>ATEX:</b> EPS 18 ATEX 2 008 X II 2G Ex h IIC T4...T2 Gb II 2D Ex h IIC T135 °C...T300 °C Db</p> <p><b>IECEx:</b> IECEx EPS 18.0007X Ex h IIC T4...T2 Gb Ex h IIC T135 °C...T300 °C Db</p> <table border="1"> <thead> <tr> <th>Temperature class</th> <th>T2</th> <th>T3</th> <th>T4</th> </tr> </thead> <tbody> <tr> <td>Maximum surface temperature</td> <td>+ 300 °C</td> <td>+ 200 °C</td> <td>+ 135 °C</td> </tr> <tr> <td>Ambient temperature</td> <td>- 40...+ 130 °C</td> <td>- 40...+ 130 °C</td> <td>- 40...+ 100 °C</td> </tr> <tr> <td>Maximum medium temperature</td> <td>+ 285 °C</td> <td>+ 185 °C</td> <td>+ 125 °C</td> </tr> </tbody> </table> <p><b>Note:</b> The ambient and medium temperature range may be limited by non-ex-relevant specifications. Observe the Operating Instructions.</p>	Temperature class	T2	T3	T4	Maximum surface temperature	+ 300 °C	+ 200 °C	+ 135 °C	Ambient temperature	- 40...+ 130 °C	- 40...+ 130 °C	- 40...+ 100 °C	Maximum medium temperature	+ 285 °C	+ 185 °C	+ 125 °C
Temperature class	T2	T3	T4														
Maximum surface temperature	+ 300 °C	+ 200 °C	+ 135 °C														
Ambient temperature	- 40...+ 130 °C	- 40...+ 130 °C	- 40...+ 100 °C														
Maximum medium temperature	+ 285 °C	+ 185 °C	+ 125 °C														

#### 3.5. Foods and beverages/Hygiene

Conformity	Description
	<p><b>3-A Sanitary Standards Inc. (valid for the variable code PE05)</b> The products comply with 3-A Sanitary Standards Inc (3-A SSI) as per certificate.</p>
FDA	<p><b>FDA – Code of Federal Regulations</b> The diaphragms made of EPDM (AD), PTFE/EPDM (EA), Advanced PTFE/EPDM (EU) and laminate of GYLON® and EPDM (ER) comply with the Code of Federal Regulations published by the FDA (Food and Drug Administration, USA).</p>
USP	<p><b>United States Pharmacopeial Convention (USP)</b> The diaphragms made of EPDM (AD), PTFE/EPDM (EA), Advanced PTFE/EPDM (EU) and laminate of GYLON® and EPDM (ER) are tested according to USP Class VI.</p>
	<p><b>EC Regulation 1935/2004 of the European Parliament and of the Council</b> The diaphragms made of EPDM (AD), PTFE/EPDM (EA), Advanced PTFE/EPDM (EU) and laminate of GYLON® and EPDM (ER) are suitable for use with food and beverages (according to EC Regulation 1935/2004/EC).</p>

DTS 1000450595 EN Version: L Status: RL (released | freigegeben | valide) printed: 09.09.2025

### 3.6. Others

Conformity	Description
TA Luft	Technical instruction on air quality control (valid for the variable code PM01)

## 4. Materials

### 4.1. Bürkert resistApp



#### Bürkert resistApp – Chemical resistance chart

You want to ensure the reliability and durability of the materials in your individual application case? Verify your combination of media and materials on our website or in our resistApp.

[Start chemical resistance check](#)

### 4.2. Material specifications

#### Actuator size 40...125

**Note:**

The exemplary representation may differ from the actual product.

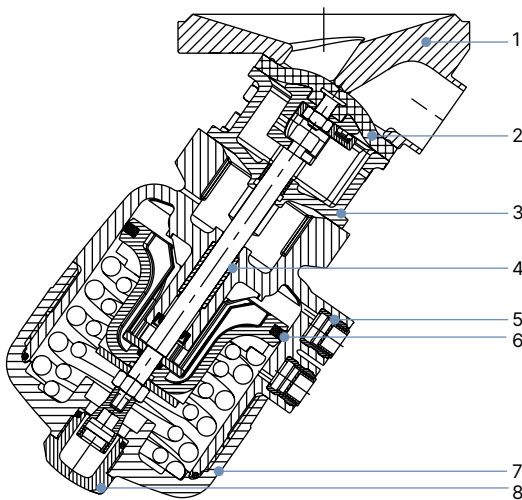

No.	Element	Material
1	Valve body	See "1. General technical data" on page 3
2	Diaphragm	EPDM (AD), PTFE/EPDM (EA), Advanced PTFE/EPDM (EU), laminate of GYLON® and EPDM (ER)
3	Interface	Stainless steel 1.4404
4	Socket	Sinter metal
5	Pilot air ports	Stainless steel 1.4305
6	Piston seal	FKM
7	Cover	Polyphenylene sulphide PPS (standard) Polyamide PA (on request)
8	Transparent cap	Polysulfone PSU

DTS 1000450595 EN Version: L Status: RL (released | freigegeben | valide) printed: 09.09.2025

**Actuator size 175 and 225**

**Note:**

The exemplary representation may differ from the actual product.

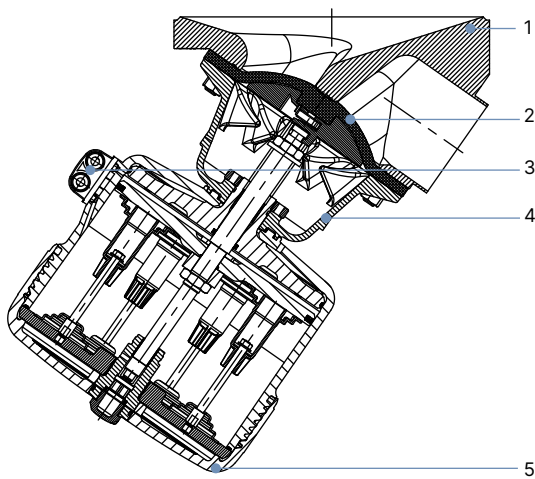

No.	Element	Material
1	Valve body	See "1. General technical data" on page 3
2	Diaphragm	EPDM (AD), PTFE/EPDM (EA), Advanced PTFE/EPDM (EU), laminate of GYLON® and EPDM (ER)
3	Pilot air ports	Stainless steel 1.4305
4	Diaphragm bonnet	Stainless steel 1.4308
5	Cover	Polyamide PA

**4.3. Example of available membrane materials**

The diaphragms have been developed to meet the unique challenges of hygienic and sterile requirements. Bürkert offers diaphragms with precise material composition and high accuracy. Bürkert diaphragms are available in a wide range of materials which have been tested and proven in applications in the food and beverage, biotechnology, pharmaceutical and cosmetics industries. The diaphragms are tested during development and production to ensure reliability under difficult process conditions.



- EPDM (AD)
- PTFE/EPDM (EA)
- Advanced PTFE/EPDM (EU)
- Laminate of GYLON® and EPDM (ER)

Further information can be found in our flyer "Diaphragm competence for hygienic applications" on our [website](#) ►.

DTS 1000450595 EN Version: L Status: RL (released | freigegeben | valide) printed: 09.09.2025

## 5. Dimensions

### 5.1. Actuator

#### CLASSIC actuator with interface for block mounting (MT85)

**Note:**

Dimensions in mm, unless otherwise stated

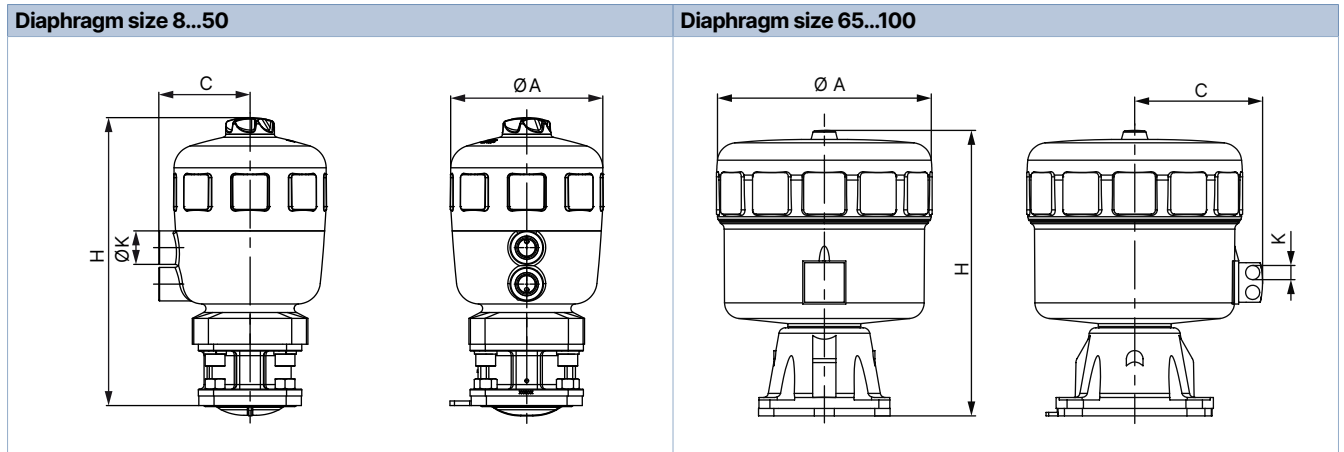

Diaphragm size	Actuator size Ø	Ø A	C	K	H
8	40 (C)	53	34	G 1/8"	111
15	50 (D)	64	39	G 1/8"	137
	63 (E)	80	52	G 1/4"	154
20	63 (E)	80	52	G 1/4"	165
	80 (F)	101	52	G 1/4"	186
25	63 (E)	80	52	G 1/4"	170
	80 (F)	101	60	G 1/4"	190
40	100 (G)	127	73	G 1/4"	246
	125 (H)	158	86	G 1/4"	284
50	100 (G)	127	73	G 1/4"	254
	125 (H)	158	86	G 1/4"	288
65	175 (K)	211	130	G 1/4"	350
80	175 (K)	211	130	G 1/4"	350
	225 (L)	261	155	G 1/4"	345
100	225 (L)	261	155	G 1/4"	345

DTS 1000450595 EN Version: L Status: RL (released | freigegeben | valide) printed: 09.09.2025

**CLASSIC actuator with tank bottom body**

**Note:**

Dimensions in mm, unless otherwise stated

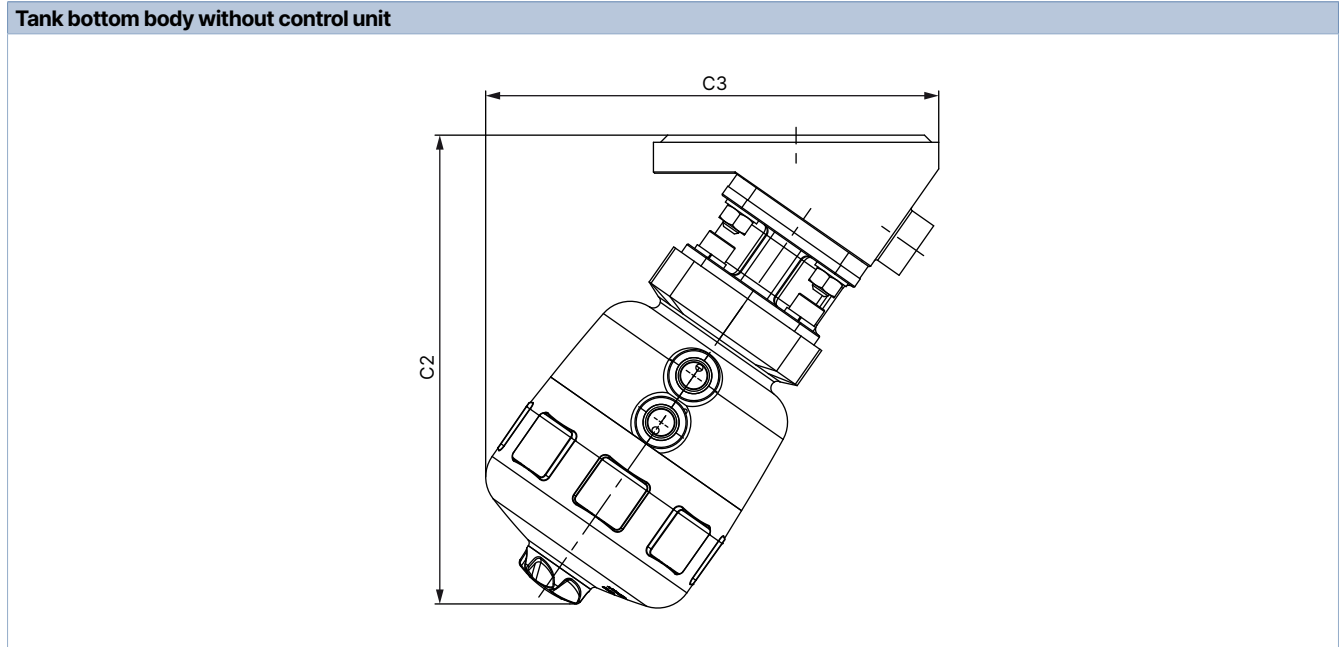

Diaphragm size	Actuator size Ø	C2	C3
15	80 (F)	–	–
20	80 (F)	190	178
25	80 (F)	199	191
40	125 (H)	296	288
50	125 (H)	304	313
65	125 (H)	394	383
	175 (K)		
80	175 (K)	390	420
	225 (L)	401	435
100	175 (K)	425	442
	225 (L)	431	455

Tank bottom body with control unit Type 8697

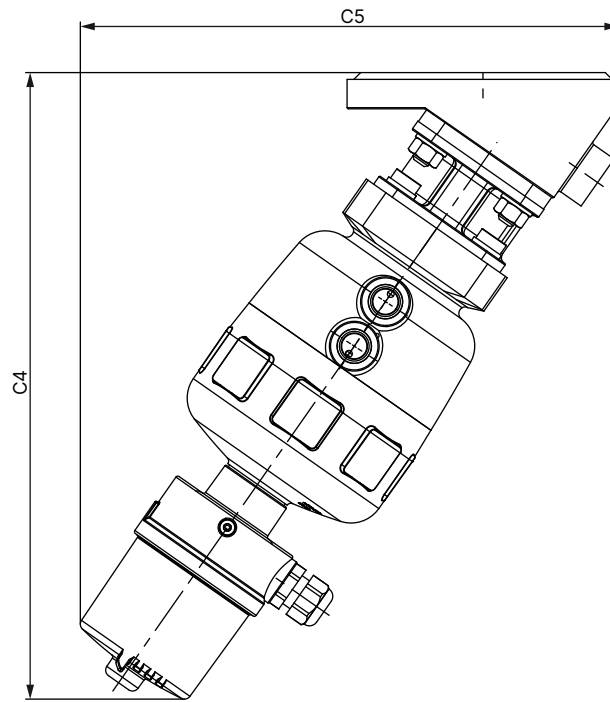

Diaphragm size	Actuator size Ø	C4	C5
15	50 (D)	215	206
	63 (E)	228	216
20	63 (E)	250	213
	80 (F)	267	225
25	63 (E)	262	228
	80 (F)	277	238
40	100 (G)	331	299
	125 (H)	369	321
50	100 (G)	340	330
	125 (H)	372	353
65	125 (H)	353	326
	175 (K)	434	382
80	175 (K)	429	434
	225 (L)	423	434
100	175 (K)	470	460
	225 (L)	464	473

DTS 1000450595 EN Version: L Status: RL (released | freigegeben | valide) printed: 09.09.2025

### 5.2. Tank bottom body with welded connection

**Note:**

Dimensions in mm, unless otherwise stated

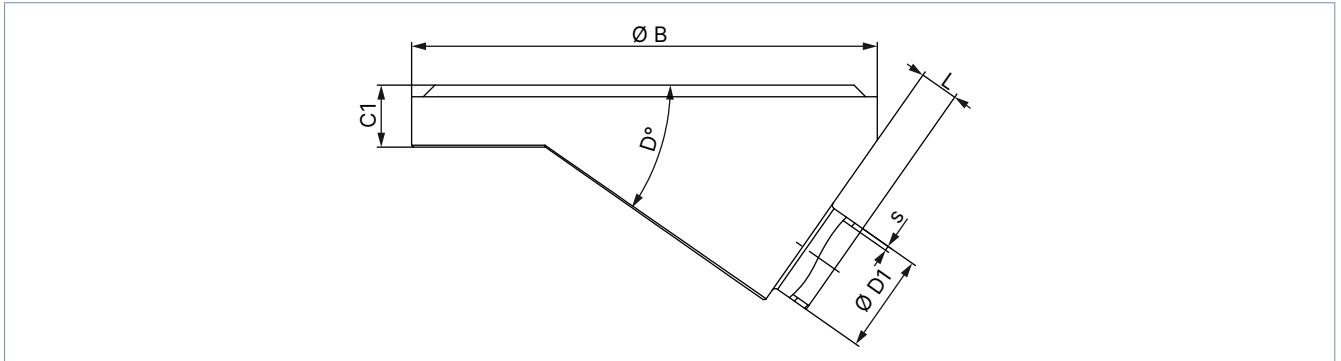

Diaphragm size	Port connection DN	Ø B	C1	D	ØD1	s	L	Product key <sup>1)</sup>	
<b>DIN EN ISO 1127 / ISO 4200 / DIN 11866 series B</b>									
8	8	50	8	35°	13.5	1.6	5	SA40	
15	15	65	12	35°	21.3	1.6	4	SA42	
		85					8	SA42	
20	20	85	12	35°	26.9	1.6	5.6	SA43	
25	25	120	16	35°	33.7	2	8	SA44	
40	32	150	18	35°	42.4 (Port 32)	2	20	SA45	
	40				48.3		15	SA46	
50	50	180	22	35°	60.3	2	12	SA47	
80	65	225	20	40°	76.1	2	16	SA48	
	80				88.9		2.3	10	SA49
100	100	298	30	40°	114.3	2.3	16.5	SA39	
<b>DIN 11850 - 2 / DIN 11866 series A / DIN EN 10357 series A</b>									
8	10	50	8	35°	13	1.5	5	SD40	
15	15	85	12	35°	19	1.5	8	SD42	
20	20	85	12	35°	23	1.5	7	SD43	
25	25	120	16	35°	29	1.5	8	SD44	
40	40	150	18	35°	41	1.5	20	SD46	
50	50	180	22	35°	53	1.5	15	SD47	
80	80	225	20	40°	85	2	16	SD49	
100	100	298	30	40°/35°	104	2	14	SD50	
<b>ASME BPE / DIN 11866 series C</b>									
8	¼"	50	8	35°	6.35	0.89	6	SA90	
15	½"	85	12	35°	12.7	1.65	10	SA92	
20	¾"	85	12	35°	19.05	1.65	8	SA93	
25	1"	120	16	35°	25.4	1.65	12	SODF	
40	1½"	150	18	35°	38.1	1.65	15	SODH	
	2"						25	SODH	
	2½"						50.8	15	SODI
80	2½"	225	20	40°	63.5	1.65	11	SODJ	
	3"						76.2	16	SODK
	4"						101.6	2.11	14
<b>SMS 3008</b>									
25	25	120	16	35°	25	1.2	8	SA60	
40	40	150	18	35°	38	1.2	20	SA62	
50	50	180	22	35°	51	1.2	15	SA63	

1.) This information is part of the product key (see "9.3. Bürkert Product Enquiry Form" on page 15).

### 5.3. Tank bottom body with clamp connection

**Note:**

- Dimensions in mm, unless otherwise stated
- The clamp dimensions must be added to the welded connection dimensions.

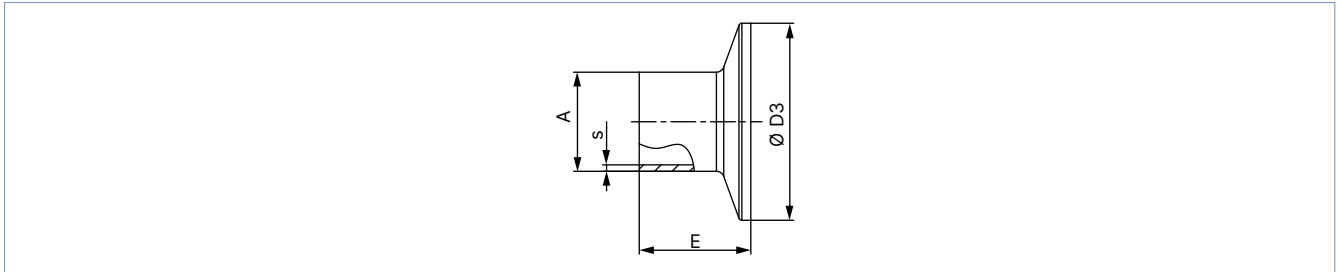

Port connection		A	s	D3	E	Product key <sup>1.)</sup>
[mm]	[inch]					
<b>DIN 32676 series A (DIN pipe)</b>						
10	–	13	1.5	34	18	TD41
15	–	19	1.5	34	18	TD42
20	–	23	1.5	34	18	TD43
25	–	29	1.5	50.5	21.5	TD44
32	–	35	1.5	50.5	21.5	TD45
40	–	41	1.5	50.5	21.5	TD46
50	–	53	1.5	64	21.5	TD47
65	–	70	2	91	28	TD48
80	–	85	2	106	28	TD49
100	–	104	2	119	28	TD50
<b>DIN 32676 series B (ISO pipe)</b>						
8	–	13.5	1.6	25	28.6	TC40
8	–	13.5	1.6	34 <sup>2.)</sup>	28.6	TC51 <sup>2.)</sup>
10	–	17.2	1.6	34 <sup>2.)</sup>	28.6	TC41 <sup>2.)</sup>
15	–	21.3	1.6	34 <sup>2.)</sup>	28.6	TC42 <sup>2.)</sup>
15	–	21.3	1.6	50.5	28.6	TC52
20	–	26.9	1.6	50.5	28.6	TC43
25	–	33.7	2	50.5	28.6	TC44
32	–	42.4	2	50.5 <sup>2.)</sup>	28.6	TC45 <sup>2.)</sup>
40	–	48.3	2	64	28.6	TC46
50	–	60.3	2	77.5	28.6	TC47
65	–	76.1	2	91	28.6	TC48
80	–	88.9	2.3	106	28.6	TC49
100	–	114.3	2.3	130	28.6	TC50
<b>ASME BPE</b>						
8	1/4"	6.35	0.89	25	28.6	TG50
10	3/8"	9.53	0.89	25	28.6	TG01
15	1/2"	12.7	1.65	25	28.6	TG02
20	3/4"	19.05	1.65	25	28.6	TG03
25	1"	25.4	1.65	50.5	28.6	TG04
40	1 1/2"	38.1	1.65	50.5	28.6	TG05
50	2"	50.8	1.65	64	28.6	TG06
65	2 1/2"	63.5	1.65	77.5	28.6	TG07
80	3"	76.2	1.65	91	28.6	TG08
100	4"	101.6	2.11	119	28.6	TG09

1.) This information is part of the product key (see "9.3. Bürkert Product Enquiry Form" on page 15).

2.) Deviating from standard because of a different outer clamp diameter

## 6. Performance specifications

### 6.1. Medium pressure

#### Information for control function A

**Note:**

- For low operating pressures, optional variants with reduced spring force (EC04) are recommended.
- Pressure data [bar]: Overpressure to atmospheric pressure.
  - Dynamic: The valve closes dynamically against the maximum operating pressure.
  - Static: When closed, the valve is pressurised on one side with the maximum operating pressure.
- Information for control function B and I is available on request.

Diaphragm size	Actuator size Ø [mm]	Pilot pressure [bar]	Maximum operating pressure for seal material			
			EPDM, FKM		PTFE/EPDM, advanced PTFE/EPDM, laminate of GYLON® and EPDM	
			Dynamic [bar]	Static [bar]	Dynamic [bar]	Static [bar]
8	40 (C)	5.0...7	10	10	10	10
15	50 (D)	5.0...7	8.5	10	–	–
	63 (E)	5.0...7	10	10	10	10
20	63 (E)	5.5...7	10	10	5	10
	80 (F)	5.0...7	10	10	10	10
25	80 (F)	5.5...7	10	10	7.5	10
40	100 (G)	5.5...7	6.5	10	6 <sup>1)</sup>	9
	125 (H)	5.5...7	10	10	10	10
50	125 (H)	5.5...7	8	10	7	10
65	175 (K)	5.0...6	8	10	5	6
80	175 (K) <sup>3)</sup>	5.0...6	5	7	3	4
	225 (L)	5.0...6	10	10	7 <sup>2)</sup>	10
100	225 (L)	5.0...6	8	10	4	7

1.) The maximum operating pressure for laminate of GYLON® and EPDM (ER diaphragm) is 4 bar.  
 2.) The maximum operating pressure for laminate of GYLON® and EPDM (ER diaphragm) is 8.5 bar.  
 3.) The tightness value only applies to laminate of GYLON® and EPDM (ER diaphragm), otherwise 0 bar for PTFE/EPDM and advanced PTFE/EPDM (EA and EU diaphragms).

## 7. Product accessories

Electric position feedback indicator	
Type 8697 ▶ Actuator size Ø 40...225 mm	
	<p>The position feedback Type 8697 is designed for integrated mounting on CLASSIC series 20XX process valves, suiting the requirements of hygienic process environments. Mechanical or inductive limit switches register the position of the valve.</p> <p><b>Features</b></p> <ul style="list-style-type: none"> <li>• Compact design</li> <li>• LED position indicator</li> <li>• Mechanical or inductive limit switches for end position registering</li> <li>• Easy-to-clean clean chemically resistant housing featuring IP65/IP67, 4X Rating</li> <li>• Optionally intrinsically safe variant according to IECEx</li> </ul> <p><b>Customer benefits</b></p> <ul style="list-style-type: none"> <li>• Easy and quick installation</li> <li>• High level of signal reliability thanks to self-adjusting limit switches</li> <li>• Minimised space requirement in the plant piping for more flexibility in plant design</li> </ul>

DTS 1000450595 EN Version: L Status: RL (released | freigegeben | valide) printed: 09.09.2025

## 8. Networking and combination with other Bürkert products

**Note:**

The **on/off CLASSIC valve system Type 8801-DG** consists of **diaphragm valve Type 2033** and a **position feedback, Type 8697**.

You order two components and receive a completely assembled and tested valve.

**Example:**

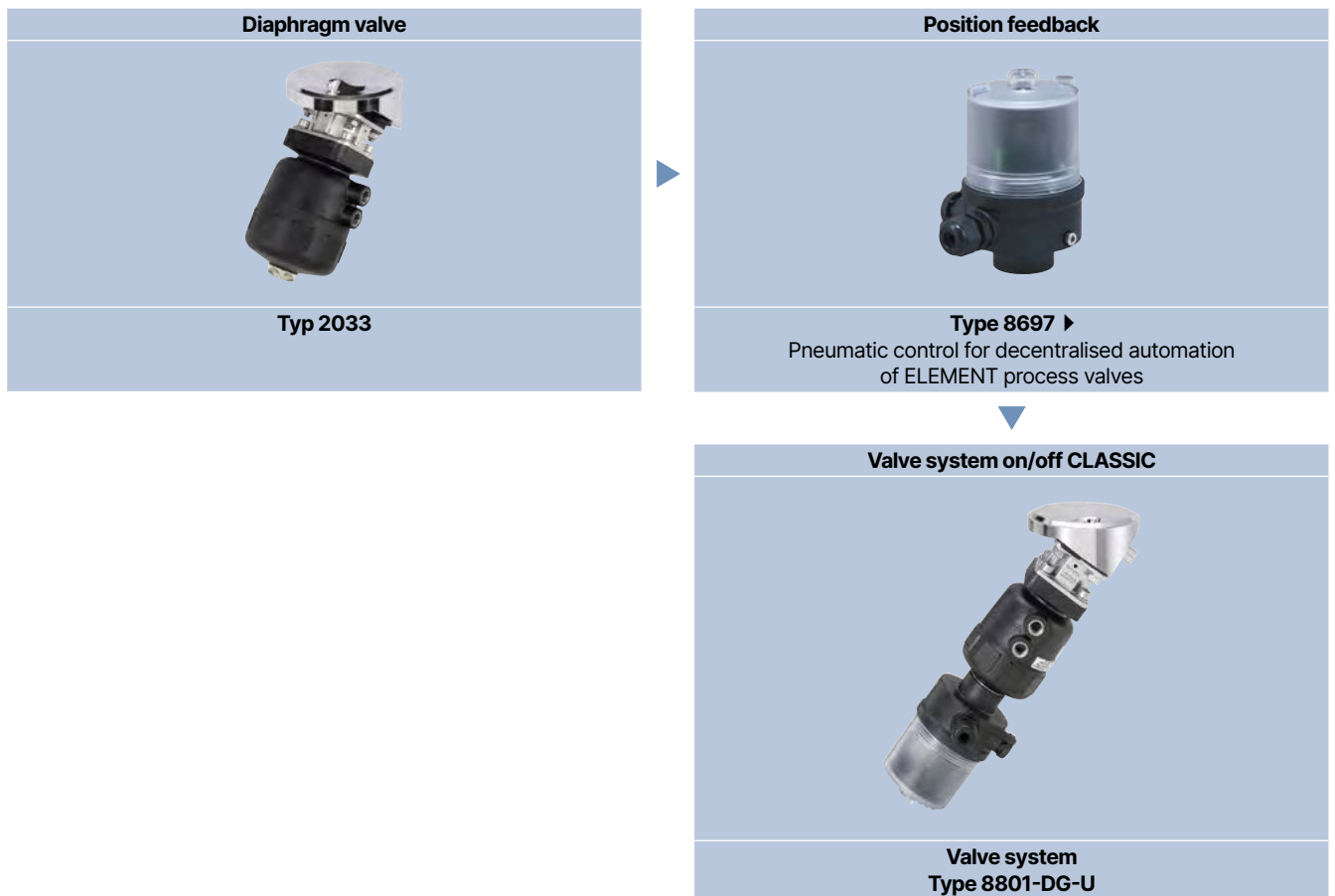

DTS 1000450595 EN Version: L Status: RL (released | freigegeben | valide) printed: 09.09.2025

## 9. Ordering information

### 9.1. Bürkert eShop



#### Bürkert eShop – Easy ordering and quick delivery

You want to find your desired Bürkert product or spare part quickly and order directly? Our online shop is available for you 24/7. Sign up and enjoy all the benefits.

[Order online now](#)

### 9.2. Bürkert product filter



#### Bürkert product filter – Get quickly to the right product

You want to select products comfortably based on your technical requirements? Use the Bürkert product filter and find suitable articles for your application quickly and easily.

[Try out our product filter](#)

### 9.3. Bürkert Product Enquiry Form

**Note:**

Please see our Product Enquiry Form for a full explanation of our specification key.

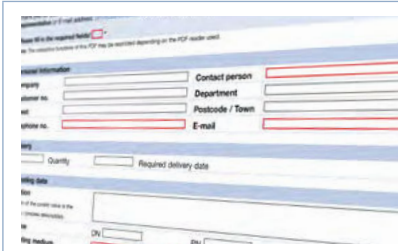

#### Bürkert Product Enquiry Form – Your enquiry quickly and compactly

Would you like to make a specific product enquiry based on your technical requirements? Use our Product Enquiry Form for this purpose. There you will find all the relevant information for your Bürkert contact. This will enable us to provide you with the best possible advice.

[Fill out the form now](#)

DTS 1000450595 EN Version: L Status: RL (released | freigegeben | valide) printed: 09.09.2025