

Industrial bimetal thermometer

Model : T111

Spec. sheet no. TD01-02

Service intended

Bimetal thermometer is used for measuring temperature of gas or fluid. It is suitable for measurement, regulation, and direct monitoring for the fluid. It meets the most stringent criteria on resistance to a corrosive atmosphere and exceptional climatic circumstances.



Nominal diameter

75, 100, 125 and 150 mm

Accuracy

±2.0 % of full scale

Temperature element

Coiled bimetal

Working range

Maximum scale value

Max. allowable pressure at stem

Under normal static conditions, the stem is designed to withstand up to 2 MPa (20 bar).

However, depending on installation conditions such as vibration, flow velocity, or pressure fluctuations, the use of a thermowell is recommended in high-temperature or high-pressure environments.



Standard features

Location of stem

Center back connection, direct

Case

304SS

Cover

304SS

Window

Glass

Dial

Metallic silver aluminium with black graduations

Pointer

Black painted aluminium alloy

Stem

6.0, 6.4, 8.0 and 10.0 mm diameter

304SS, 316SS and 316L SS

Max. Insertion length : 2,000 mm

Zero adjustment

External

Stem, process connection

¼", ⅜", ½", ¾" PT, NPT and PF

Option

±1.0 % of full scale

Certificates

ATEX II 2G Ex h IIC T6...T1 Gb /

ATEX II 2D Ex h IIIC T85°C...T450°C Db

Main order

Ordering information

1. Base model

T111 Industrial bimetal thermometer

2. Nominal diameter (mm)

3 75
4 100
5 125
6 150

3. Type of mounting

X Center back connection, direct

4. Stem material

0 304SS
1 316SS
2 316L SS

5. Stem, process connection

A None
C 1/4"
D 3/8"
E 1/2"
F 3/4"
G 1 1/2S (Only available with sanitary)
H 2S (Only available with sanitary)
I 2 1/2S (Only available with sanitary)

6. Stem connection type (CF: Compression fitting)

A None
B PF
C PT
D NPT
E CF + PT
F CF + NPT
G CF + PF
H MT + PT (Movable thread)
I MT + NPT (Movable thread)
J MT + PF (Movable thread)
S Clamp (Sanitary type flange)

7. Stem outer diameter (mm)

0 6.0
1 6.4
2 8.0
3 10.0 (Not available process connection, 1/4")

8. Range

XXX Refer to scale range table

9. Insertion length

X Refer to insertion length table

10. Accessories

0 None
1 Thermowell
2 Special accuracy (± 1.0 % of full scale)
3 Thermowell and special accuracy

Sample ordering code

1	2	3	4	5	6	7	8	9	10
T111	4	X	0	E	C	1	XXX	X	1



© WISE Control Inc. All rights reserved. ALL PRODUCT, PRODUCT SPECIFICATIONS AND DATA ARE SUBJECT TO CHANGE WITHOUT NOTICE TO IMPROVE RELIABILITY, FUNCTION OR DESIGN OR OTHERWISE.

T111 : Type of mounting

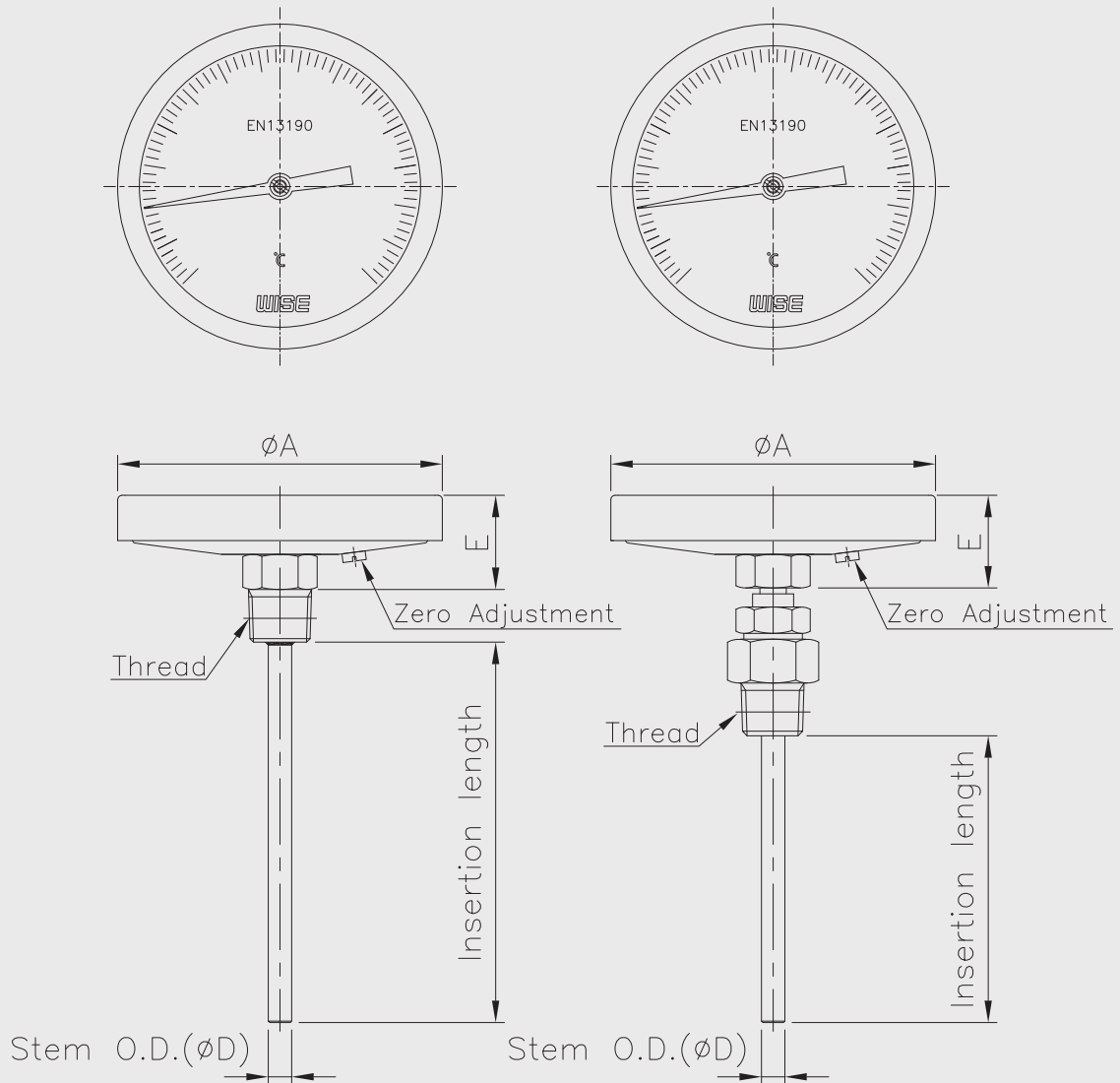

Dimensions (mm)

Dial Size	A	E ± 2
75	86.5	28
100	111	32
125	137.5	30
150	169.5	43

Scale ranges

Code	Scale range (°C)	Scale spacing (°C)	Minimum stem length (mm)	
			6.0 and 6.4	8.0 and 10.0
032	-50 ~ 50	2	55	50
037	-50 ~ 100	2	45	35
054	-30 ~ 50	2	70	60
059	-30 ~ 100	2	50	45
061	-30 ~ 120	2	45	35
069	-20 ~ 50	2	80	70
074	-20 ~ 100	2	45	45
079	-20 ~ 150	5	40	35
084	-10 ~ 50	1	95	80
099	0 ~ 50	1	110	70
100	0 ~ 60	1	95	80
101	0 ~ 70	2	80	60
102	0 ~ 80	2	70	55
104	0 ~ 100	2	55	50
106	0 ~ 120	2	50	45
109	0 ~ 150	2	45	35
114	0 ~ 200	5	35	35
119	0 ~ 250	5	35	30
124	0 ~ 300	5	35	25
129	0 ~ 350	5	30	25
134	0 ~ 400	5	80	65
144	0 ~ 500	10	70	60
154	0 ~ 600	10	70	60

* Dial size 65 mm : Minimum stem length 60 mm

Insertion length

Code	1	2	3	4	5	6	7	8	9	A	B	C
Length (mm)	50	60	70	80	100	120	130	150	175	200	225	250

Code	D	E	F	G	H	J	K	L	M	N	P
Length (mm)	275	300	350	375	400	450	500	550	1,000	1,500	2,000