

General service bimetal thermometer

Model : T114

Spec. sheet no. TD01-04

Service intended

Bimetal thermometer is used for measuring temperature of gas or fluid. It is suitable for measurement, regulation and direct monitoring for the fluid. It meets the most stringent criteria on resistance to a corrosive atmosphere and exceptional climatic circumstances.



Nominal diameter

75 and 100 mm

Accuracy

±2.0 % of full scale

Temperature element

Coiled bimetal

Working range

Maximum scale value

Max. allowable pressure at stem

Under normal static conditions, the stem is designed to withstand up to 2 MPa (20 bar).

However, depending on installation conditions such as vibration, flow velocity, or pressure fluctuations, the use of a thermowell is recommended in high-temperature or high-pressure environments.

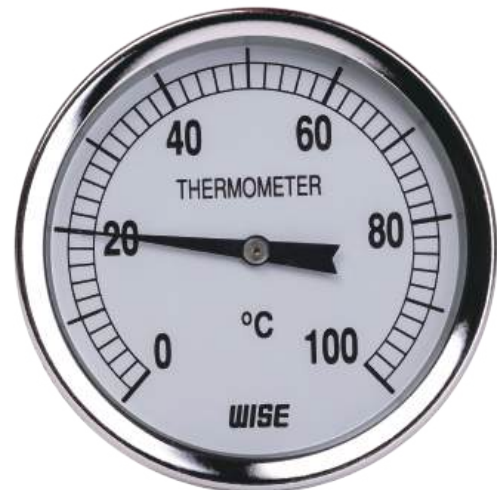

Standard features

Location of stem

Center back connection, direct

Pointer

Black painted aluminium alloy

Case

Nickel plated steel

Stem

6.4 mm diameter
304SS, 316SS and 316L SS
Max. Insertion length : 400 mm

Cover

Nickel plated steel

Window

Glass

Dial

Metallic silver aluminium with black graduations

Stem, process connection

1/4", 3/8", 1/2" PT, NPT and PF

1. Base model

T114 General service bimetal thermometer

2. Nominal diameter (mm)

- 3 75
- 4 100

3. Type of mounting

X Center back connection, direct

4. Stem material

- 0 304SS
- 1 316SS
- 2 316L SS

5. Stem, process connection

- C 1/4"
- D 3/8"
- E 1/2"

6. Stem connection type (CF: Compression fitting)

- A None
- B PF
- C PT
- D NPT
- E CF + PT
- F CF + NPT
- G CF + PF

7. Stem outer diameter (mm)

- 1 6.4

8. Range

XXX Refer to scale range table

9. Insertion length

X Refer to insertion length table

10. Accessories

- 0 None
- 1 Thermowell

Sample ordering code

1	2	3	4	5	6	7	8	9	10
T114	3	X	0	E	C	1	XXX	X	1



© WISE Control Inc. All rights reserved. ALL PRODUCT, PRODUCT SPECIFICATIONS AND DATA ARE SUBJECT TO CHANGE WITHOUT NOTICE TO IMPROVE RELIABILITY, FUNCTION OR DESIGN OR OTHERWISE.

T114 : Type of mounting

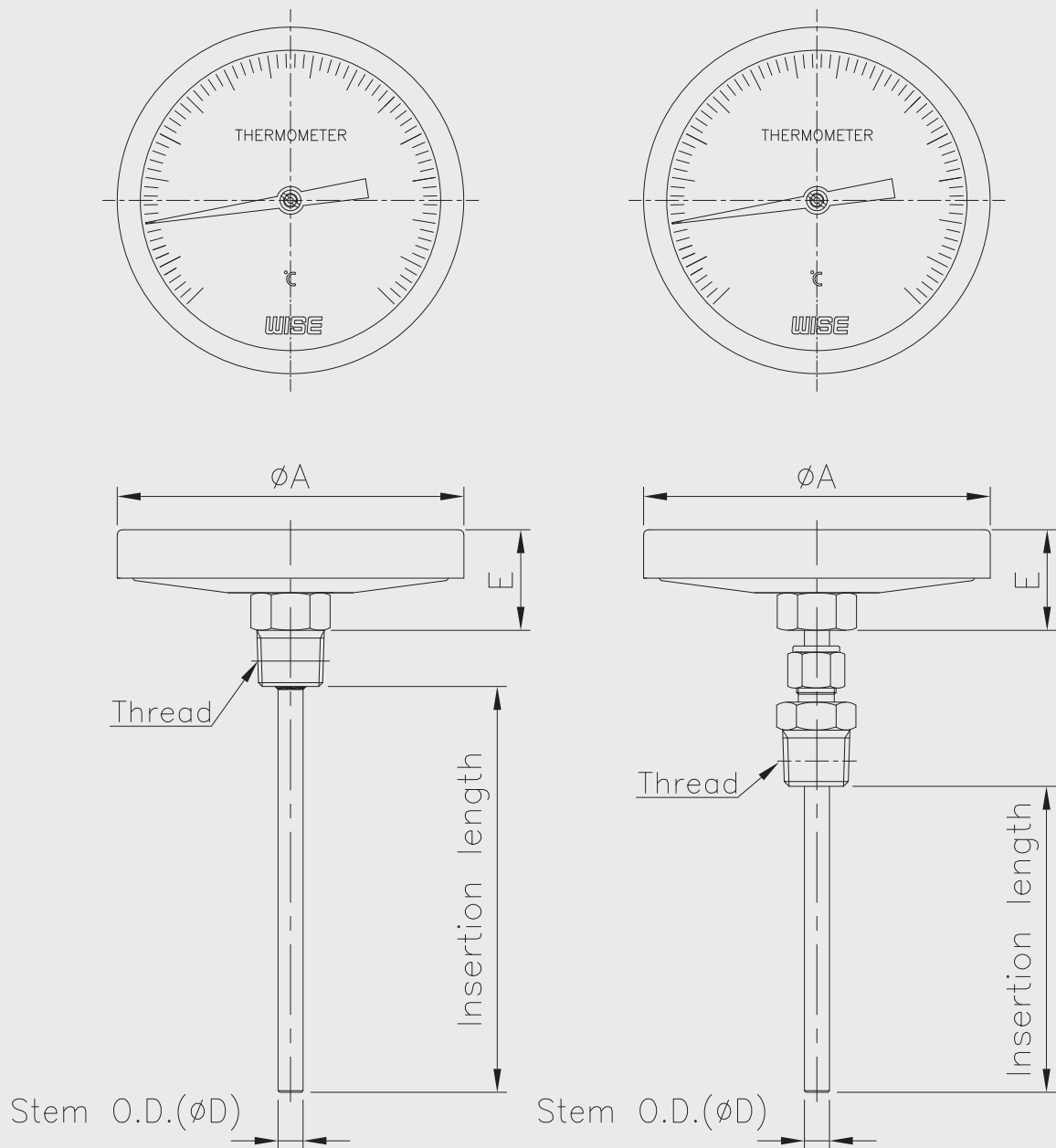

Dimensions (mm)

Dial Size	A	E±2
75	86.5	28
100	111	32

Scale ranges

Code	Scale range (°C)	Scale spacing (°C)	Minimum stem length (mm)
099	0 ~ 50	1	110
101	0 ~ 70	2	80
102	0 ~ 80	2	70
104	0 ~ 100	2	60
109	0 ~ 150	5	60
114	0 ~ 200	5	60
119	0 ~ 250	5	60
124	0 ~ 300	5	60
129	0 ~ 350	5	60

Insertion length

Code	2	3	4	5	6	7	8	9
Length (mm)	60	70	80	100	120	130	150	175
Code	A	B	C	D	E	F	G	H
Length (mm)	200	225	250	275	300	350	375	400