

Helical strake type thermowell

Model : A650 series

Spec. sheet no. AD06-06



Service intended

Thermowell is manufactured and calculated according to ASME PTC 19.3 TW-2016 to protect it from the loads of the flux. If the calculated value is not appropriate, then shorten the length of the Thermowell, and increase the root and the tip diameter of the Thermowell to change the outcome value, or try to change the structure by installing the support collar on the Thermowell.

However, these changes have its own limits.

A650 Series could reduce the amplitude of oscillation by 70 %, and reduce the danger of breakage of Thermowell by VIV (Vortex Induced Vibration).

Furthermore, because it reduces the loads on the Thermowell, it makes the installation possible without installing the support collar and without the change of Nozzle.



Description

Standard type thermowell

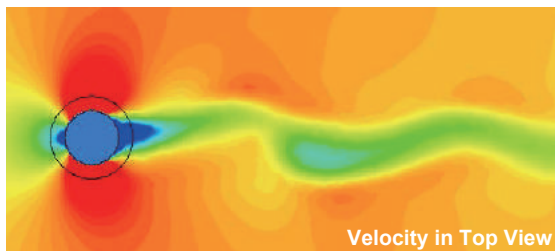

The oscillation of vortices which is caused by VIV can be found around the Thermowell. If the vortex shedding frequency approaches to the natural frequency, then the resonance could cause the breakage of the Thermowell.

A650 type thermowell

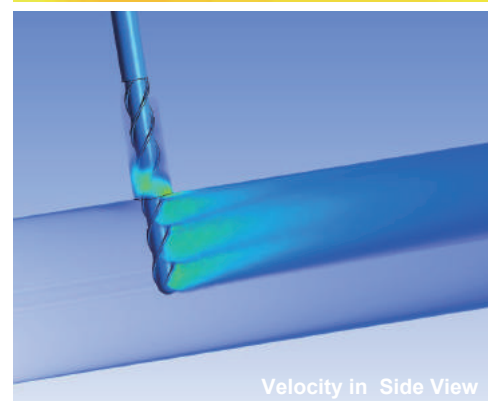
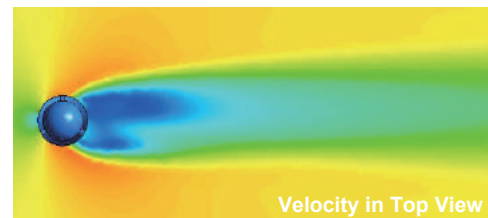

By comparing the standard Thermowell with A650 Series, the noticeable decrease of the vortices could be found around the A650 Series. Furthermore, it could reduce the chance of breakage of the Thermowell which is caused by VIV.



1. Base model

A6510 Flanged Type Thermowell
A6520 Vanstone Type Thermowell
A6530 Socket Type Thermowell

2. Material of well

BX 304SS
CX 316SS
DX 304L SS
EX 316L SS
FX 310SS
ZX Others

3. Material of flanged

BX 304SS
CX 316SS
DX 304L SS
EX 316L SS
FX 310SS
ZX Others

4. Internal connection

0 ½" NPT
1 ½" PT
2 ½" PF

5. Tip outer diameter / Bore size (mm)

E0 20 / 7 **E1** 20 / 9

6. Flange size

C 1" (25A) **G** 2½" (65A)
D 1¼" (32A) **H** 3" (80A)
E 1½" (40A) **I** 4" (100A)
F 2" (50A) **Z** Other

7. Process connection type

DA PN10 RF	AW 900Lb RTJ
DB PN16 RF	AT 1,500Lb RF
AE 150Lb FF	AX 1,500Lb RTJ
AC 150Lb RF	AU 2,500Lb RF
AD 150Lb RFSF	AY 2,500Lb RTJ
AH 300Lb FF	KN 10K FF
AF 300Lb RF	KL 10K RF
AG 300Lb RFSF	KM 10K RFSF
DI PN25 RF	KR 20K FF
AJ 600Lb RF	KP 20K RF
AK 600Lb RFSF	KQ 20K RFSF
AV 600Lb RTJ	DO PN40 RF
AS 900Lb RF	ZZ Other

8. Insertion length ("U") length (mm)

3 200	B 600
4 250	C 700
5 300	D 800
6 350	E 900
7 400	F 1,000
8 450	Z Other
A 500	

Note : Please choose a code of next higher length if applicable length is not.
Actual length shall be specified.

9. "T" length (mm)

0 45
1 50 below
2 50 above

Note : Actual length shall be specified.
A5100: "T"length is designed with 70 mm or longer in case of flange thickness more than 28 mm. (Flange thickness is more than 50mm, please contact the head office before selecting.)

10. Option

0 None
1 Plug and chain (304SS)
2 Plug and chain (316SS)
8 F.P welding (Only flanged type)

Note : Actual length shall be specified.

Sample ordering code

1	2	3	4	5	6	7	8	9	10
A6510	BX	BX	0	E0	C	DA	3	0	1

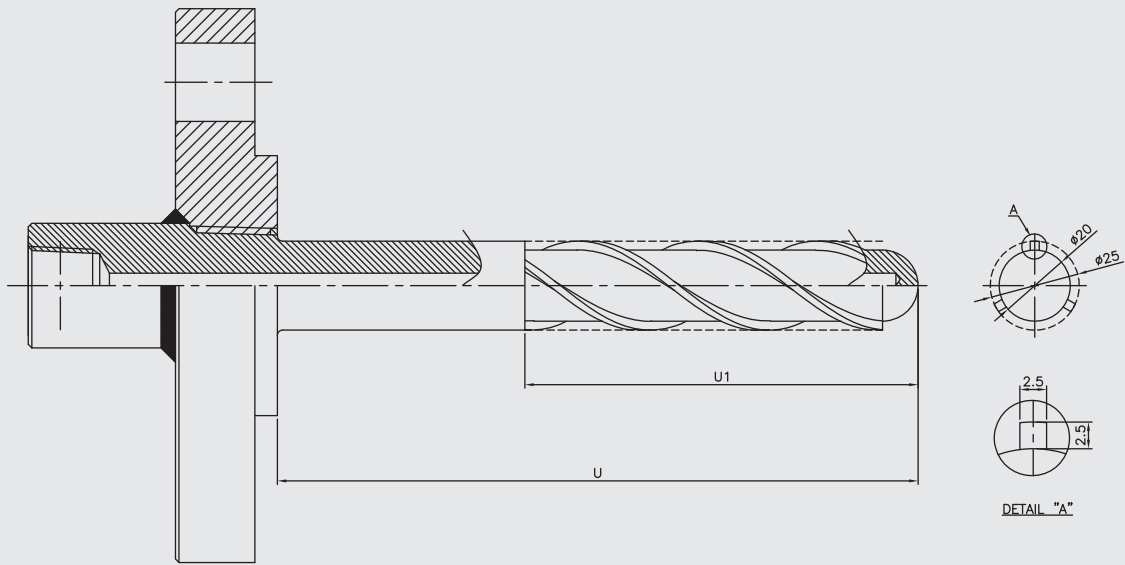

FLANGED TYPE

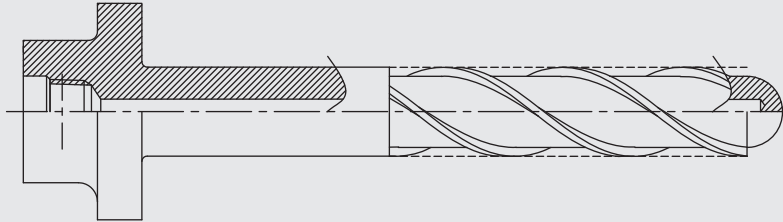

VANSTONE TYPE

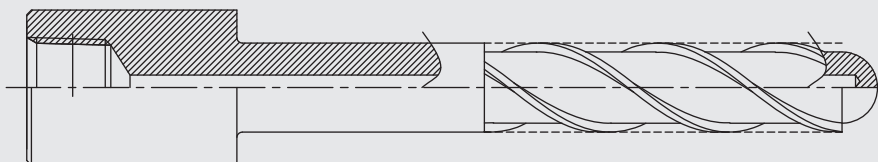

SOCKET WELDED TYPE

FEDSM2020-20047

FLOW MEASUREMENT WITH A HELICAL STRAKE TYPE THERMOWELL IN FLOW MEASUREMENT STANDARD SYSTEMS

Kisung Kim¹, Sibok Lee¹
¹WISE Control Inc.
Seoul, Republic of Korea

Sejong Chun^{2,3}
²University of Science and Technology
Daejeon, Republic of Korea
³Korea Research Institute of Standards and Science
Daejeon, Republic of Korea

ABSTRACT

Helical strake type thermowells are replacing standard thermowells according to ASME PTC 19.3 TW-2016 in various industrial sectors. It is because the helical strakes can suppress the flow-induced vibration by Kármán vortex street over a thermowell. However, the ASME PTC 19.3 TW-2016 does not regulate the helical strakes because their design rules are too complicated to be specified.

This study attempts to characterize the effect of helical strakes on the thermowell vibrations by measuring pressure and strain signals at the same time. The pressure signal is expected to give information on the Kármán vortex street while the strain signal gives the flow-induced vibration on the thermowells. Relative vibration energy or relative vibration amplitude is defined to calculate the efficiency of suppressing the Kármán vortex street around the thermowells.

Keywords: Flow induced vibration, Helical strake, Thermowell

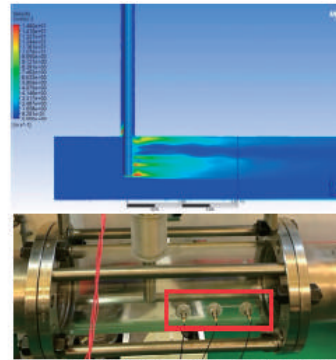

FIGURE 3: LOCATION OF DYNAMIC PRESSURE TRANSDUCER (TOP: NUMERICAL SIMULATION, BOTTOM: EXPERIMENT)

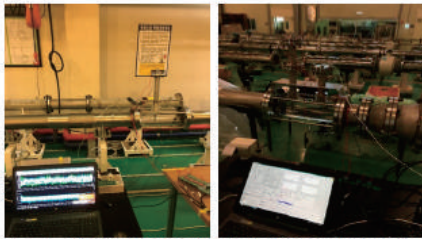

FIGURE 1: FLOW STANDARDS (LEFT: GAS FLOW, RIGHT: WATER FLOW)

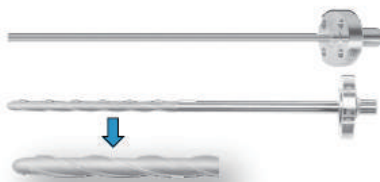

FIGURE 2: THERMOWELLS (TOP: STANDARD, BOTTOM: HELICAL STRAKE TYPE)

* Note

This study was financially supported by Korea Research Institute of Standards and Science (19011286;20011027), Republic of Korea.